

# Paper Models of Polyhedra

Gijs Korthals Altes

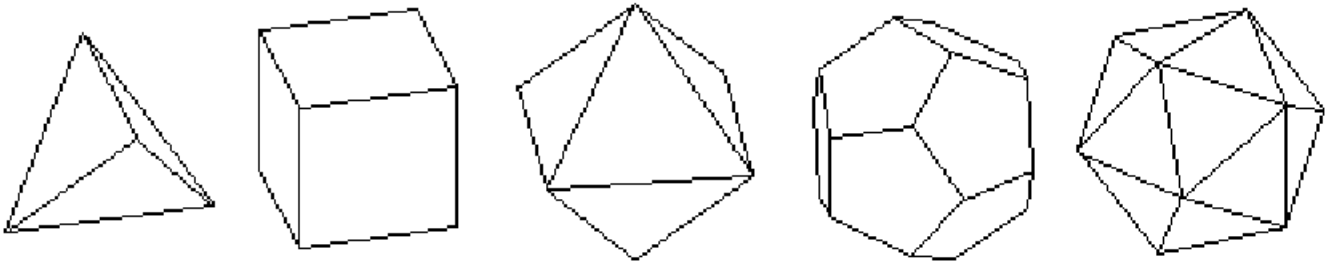

Polyhedra are beautiful 3-D geometrical figures that have fascinated philosophers, mathematicians and artists for millennia



Copyrights © 1998-2001 Gijs.Korthals Altes All rights reserved .  
It's permitted to make copies for non-commercial purposes only  
email: [gijs@korthals.altes.net](mailto:gijs@korthals.altes.net)

# Paper Models of Polyhedra

## Platonic Solids

Dodecahedron  
Cube and Tetrahedron  
Octahedron  
Icosahedron

## Archimedean Solids

Cuboctahedron  
Icosidodecahedron  
Truncated Tetrahedron  
Truncated Octahedron  
Truncated Cube  
Truncated Icosahedron (soccer ball)  
Truncated dodecahedron  
Rhombicuboctahedron  
Truncated Cuboctahedron  
Rhombicosidodecahedron  
Truncated Icosidodecahedron  
Snub Cube  
Snub Dodecahedron

## Kepler-Poinsot Polyhedra

Great Stellated Dodecahedron  
Small Stellated Dodecahedron  
Great Icosahedron  
Great Dodecahedron

## Other Uniform Polyhedra

Tetrahemihexahedron  
Octahemioctahedron  
Cubohemioctahedron  
Small Rhombihexahedron  
Small Rhombidodecahedron  
Small Dodecahemiododecahedron  
Small Ditrigonal Icosidodecahedron  
Great Dodecahedron

## Compounds

Stella Octangula  
Compound of Cube and Octahedron  
Compound of Dodecahedron and Icosahedron  
Compound of Two Cubes  
Compound of Three Cubes  
Compound of Five Cubes  
Compound of Five Octahedra  
Compound of Five Tetrahedra  
Compound of Truncated Icosahedron and Pentakisidodecahedron

Other Polyhedra  
Pentagonal Hexecontahedron  
Pentagonalconsitetrahedron  
Pyramid  
Pentagonal Pyramid  
Decahedron  
Rhombic Dodecahedron  
Great Rhombihexacron  
Pentagonal Dipyramid  
Pentakisdodecahedron  
Small Triakisoctahedron  
Small Triambic Icosahedron  
Polyhedra Made of Isosceles Triangles  
Third Stellation of the Icosahedron  
Sixth Stellation of the Icosahedron  
Seventh Stellation of the Icosahedron  
Eighth Stellation of the Icosahedron  
Ninth Stellation of the Icosahedron  
Final Stellation of the Icosahedron

Prism and Antiprism  
Triangular Prism  
Pentagonal Prism  
Pentagonal Antiprism  
Triangular Prism  
Octagonal Prism  
Octagonal Antiprism  
Pentagrammic Prism  
Pentagrammic Antiprism  
Hexagrammic Prism  
Hexagrammic Antiprism  
Twisted Rectangular Prism

Kaleidocycles  
Hexagonal Kaleidocycle  
Octagonal Kaleidocycle  
Decagonal Kaleidocycle

Other Paper Models  
Cylinder  
Tapered Cylinder  
Cone  
Special Cones  
"Matryoska house"  
"Matryoska house" 50%  
Globe  
Chevaux-de-frise

Dodecahedron

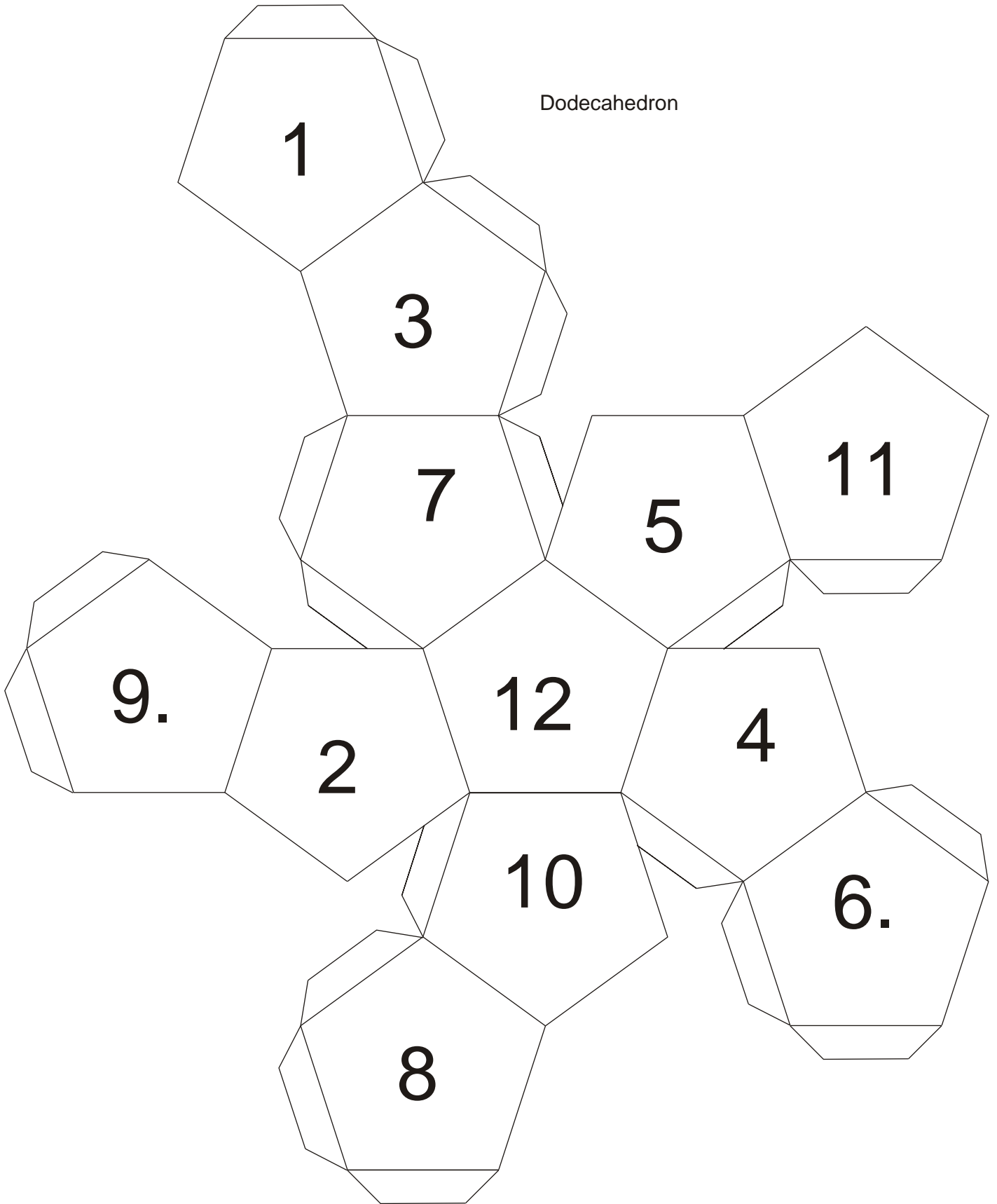

Dodecahedron

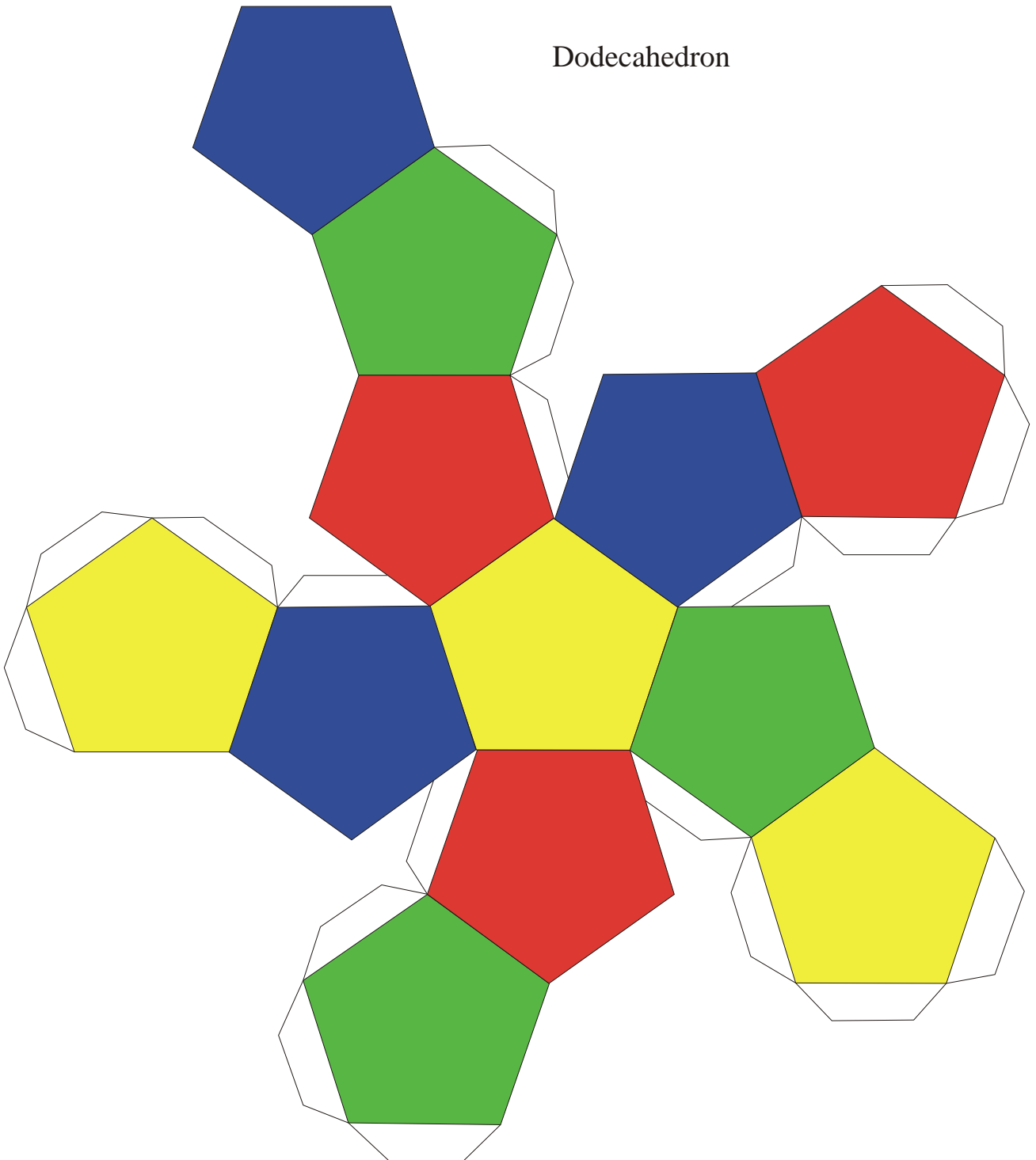

Dodecahedron

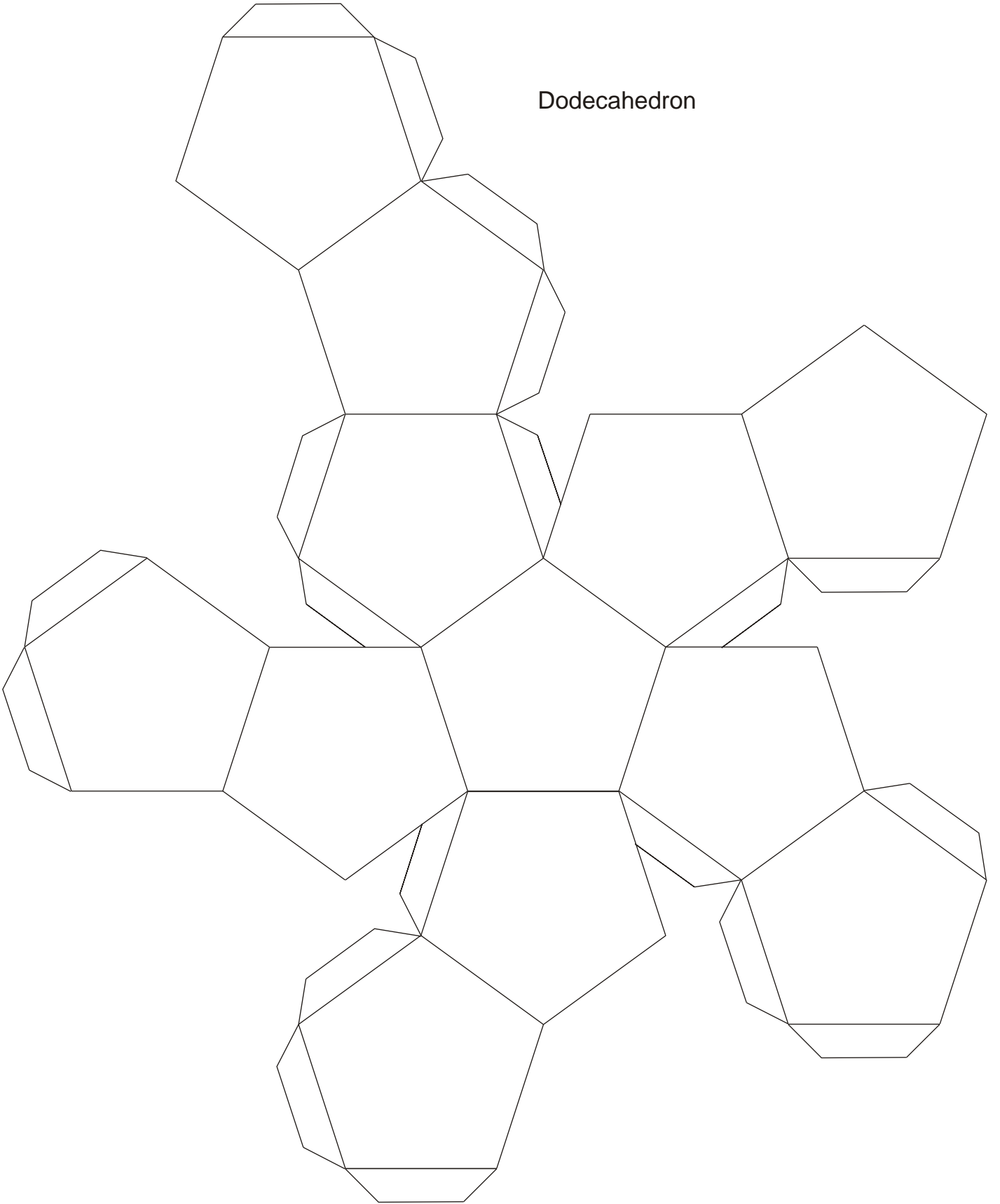

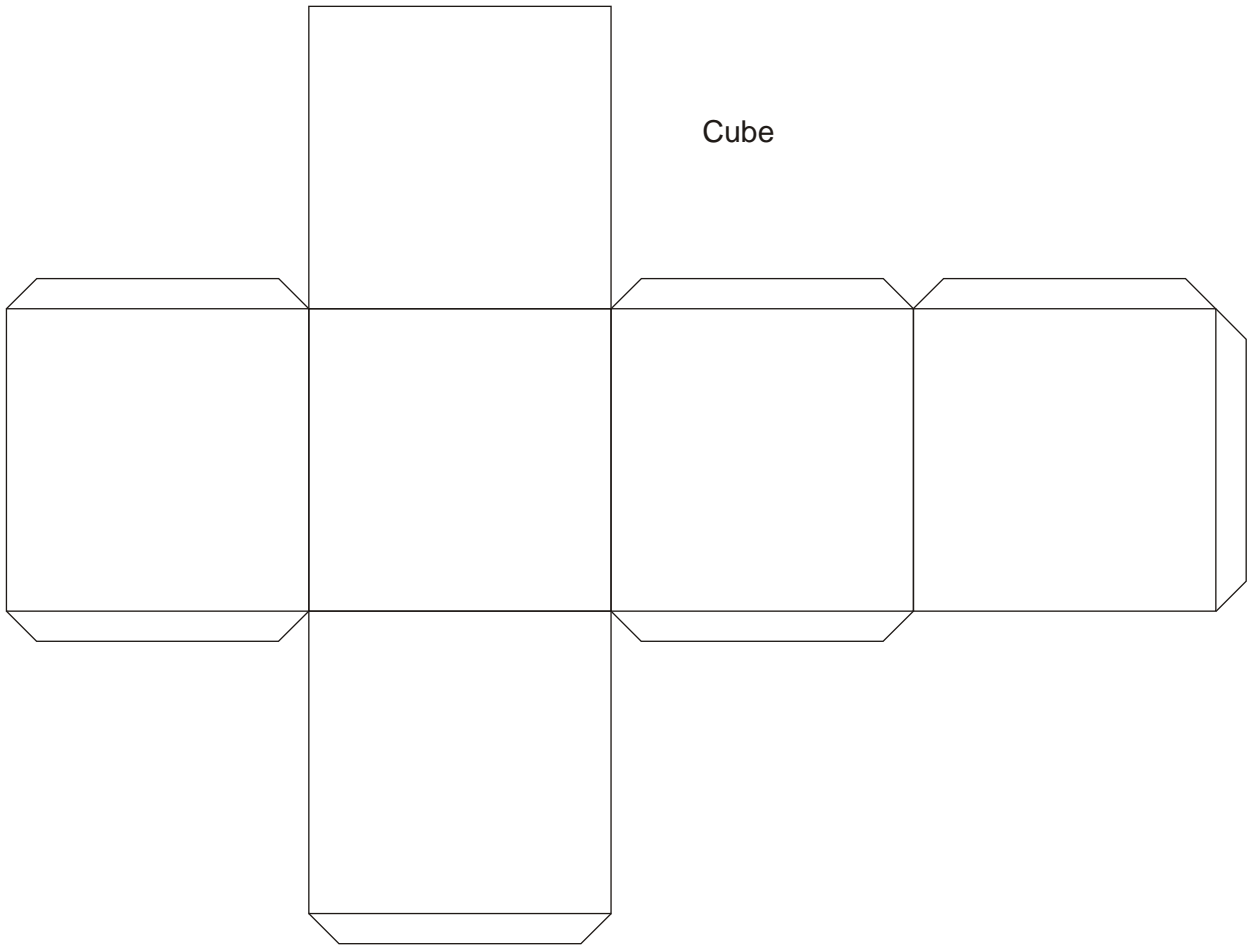

Cube

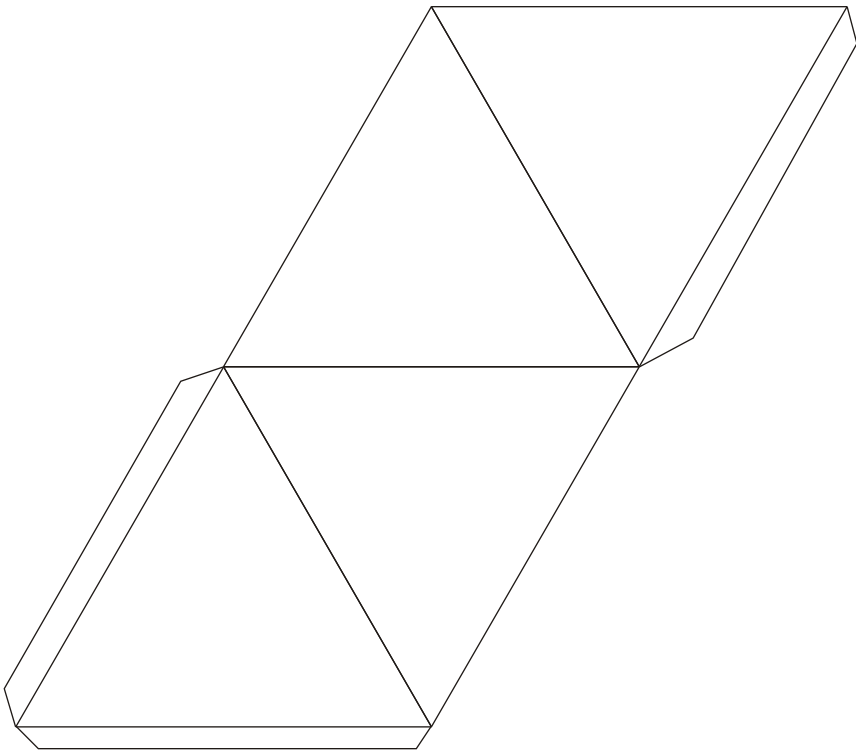

Tetrahedron



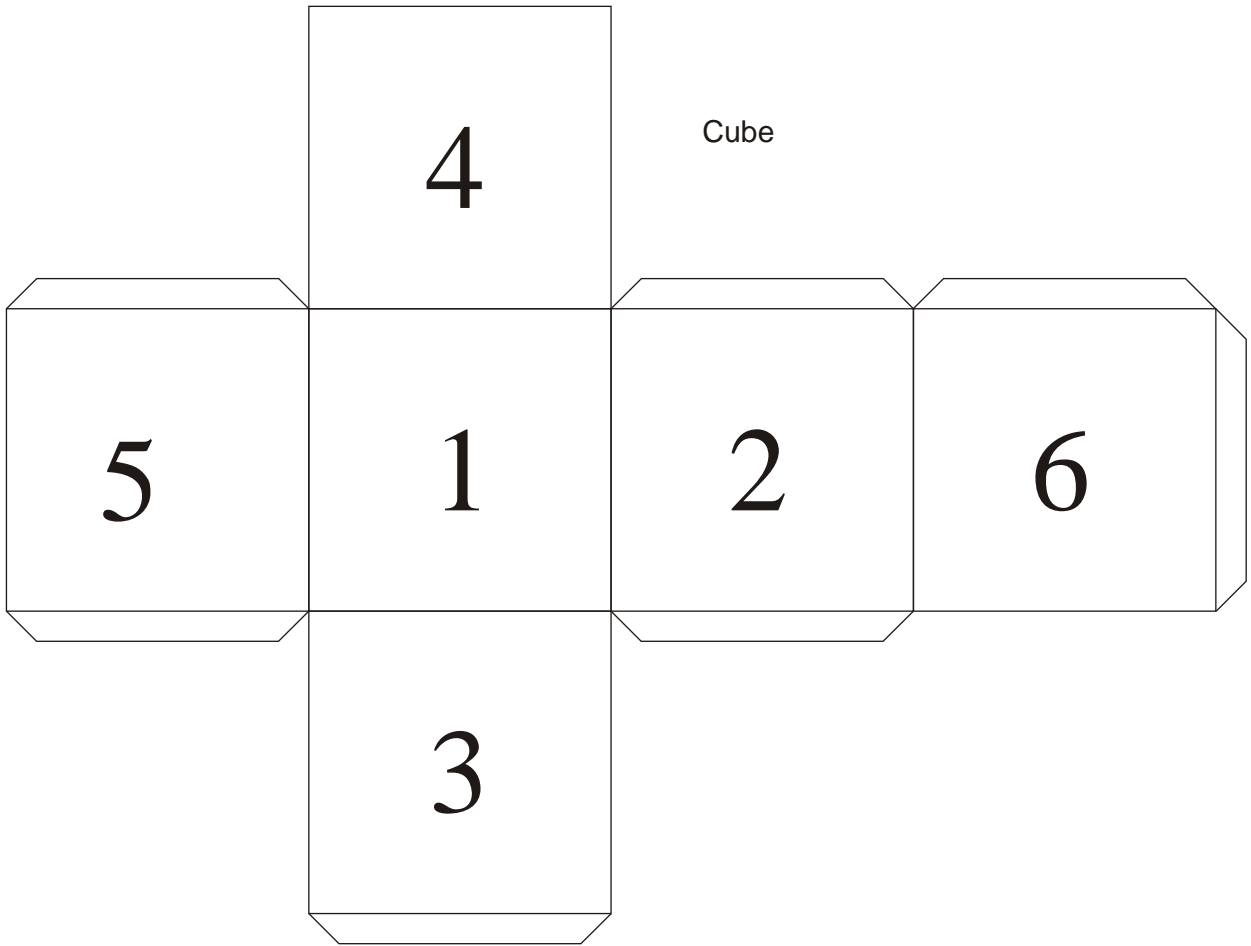

Cube

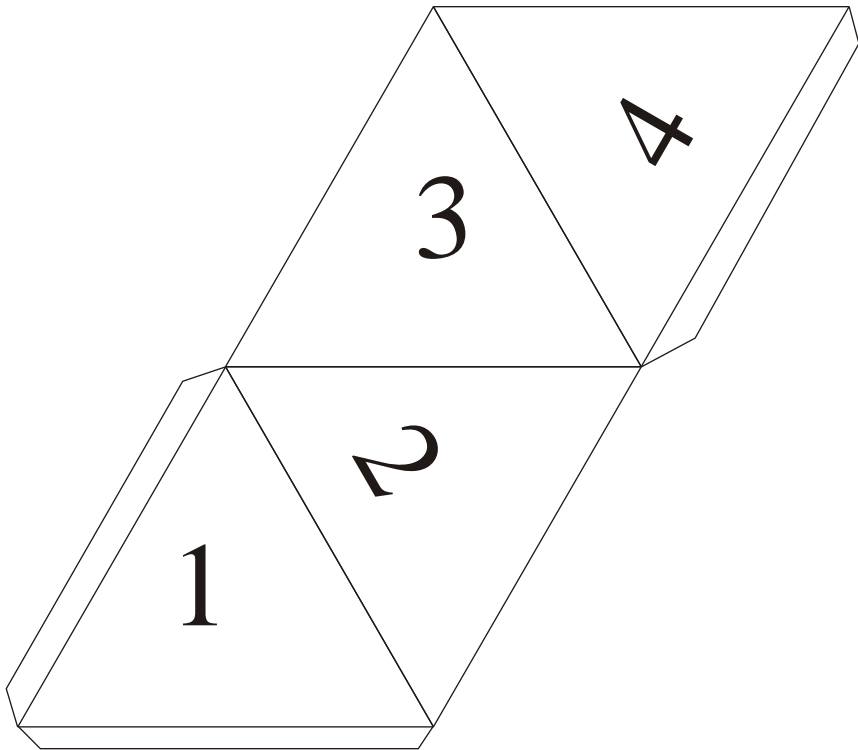

Tetrahedron

Octahedron

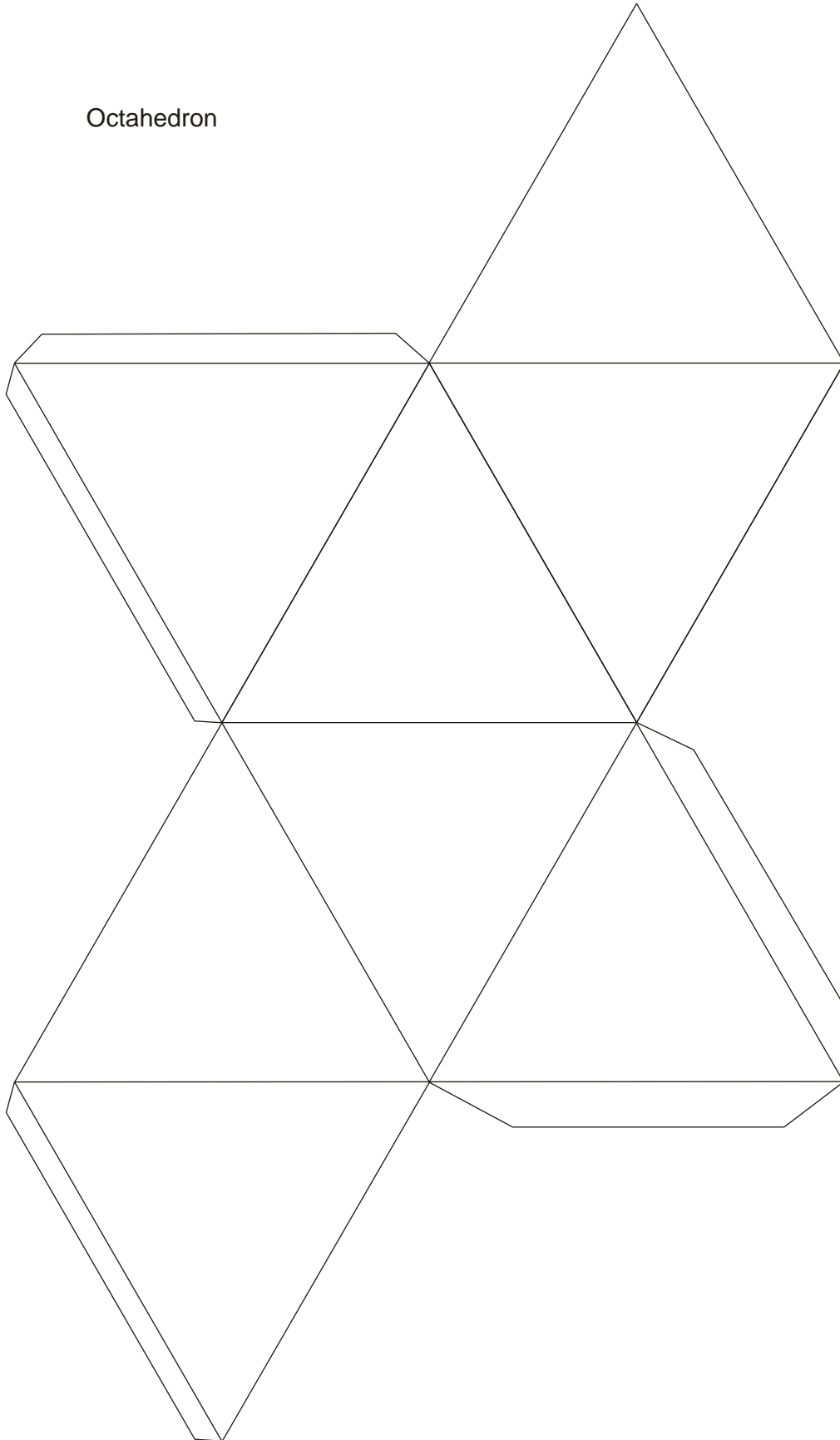

Icosahedron

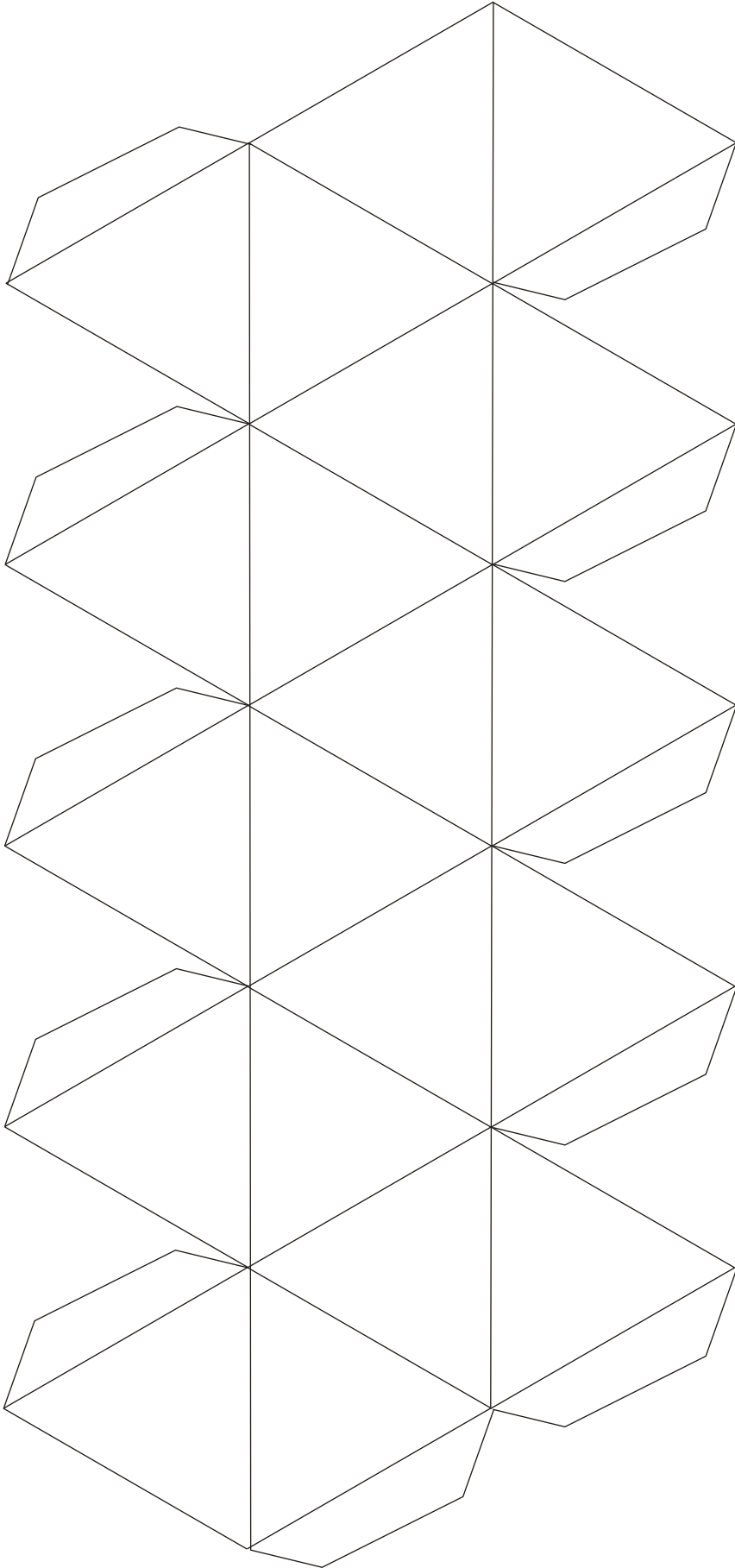

Cuboctahedron

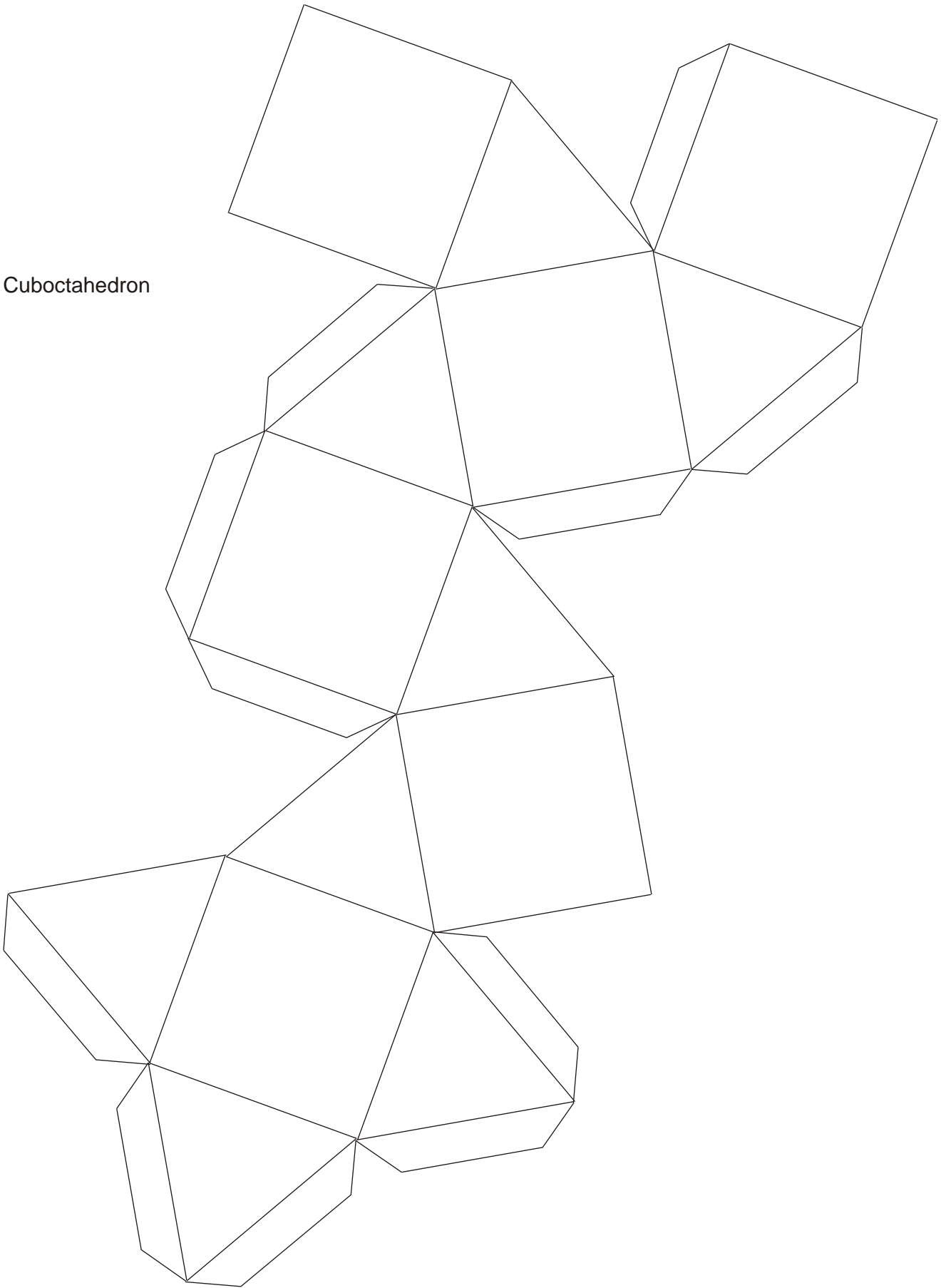

Icosidodecahedron

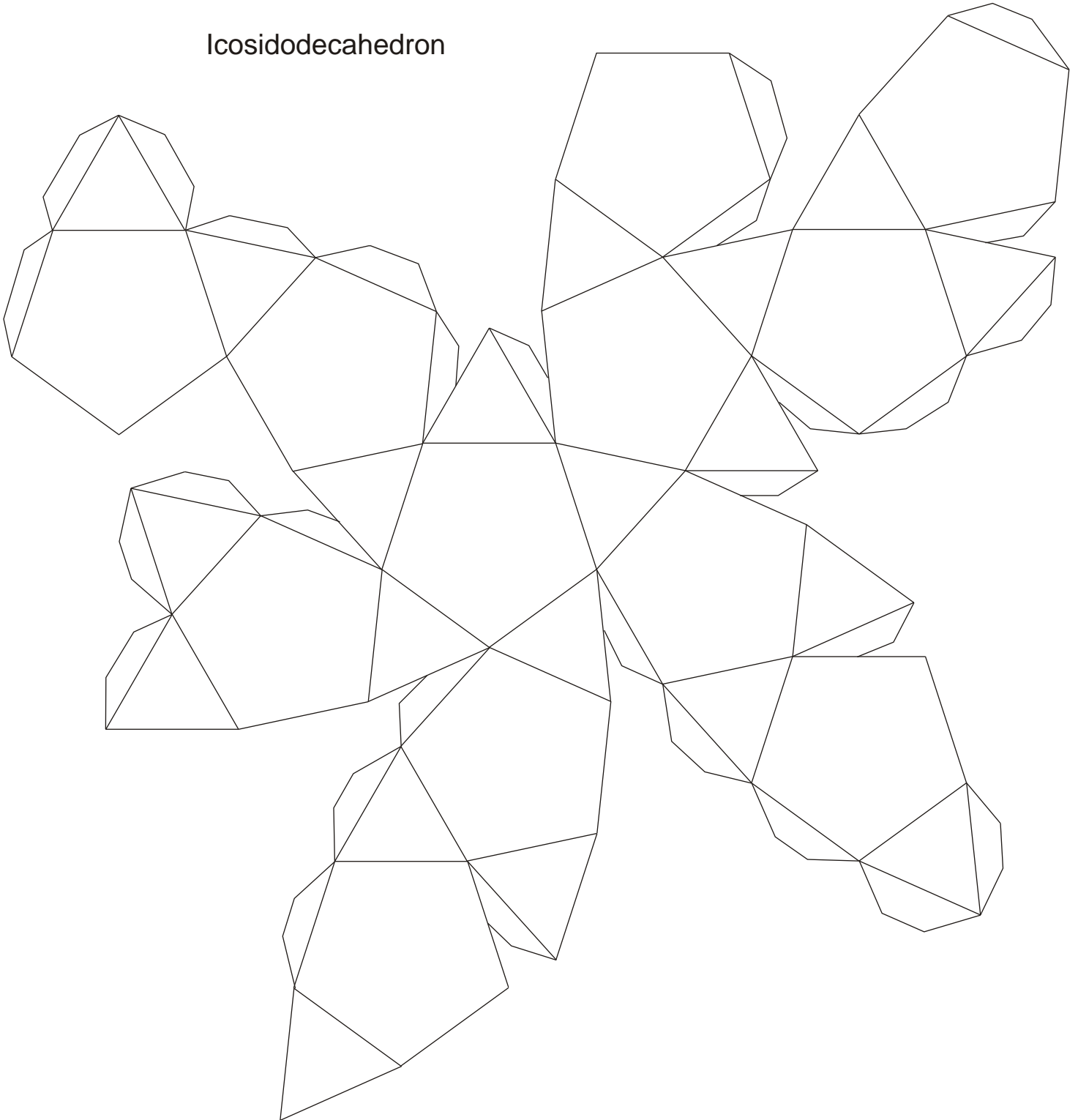

Truncated Tetrahedron

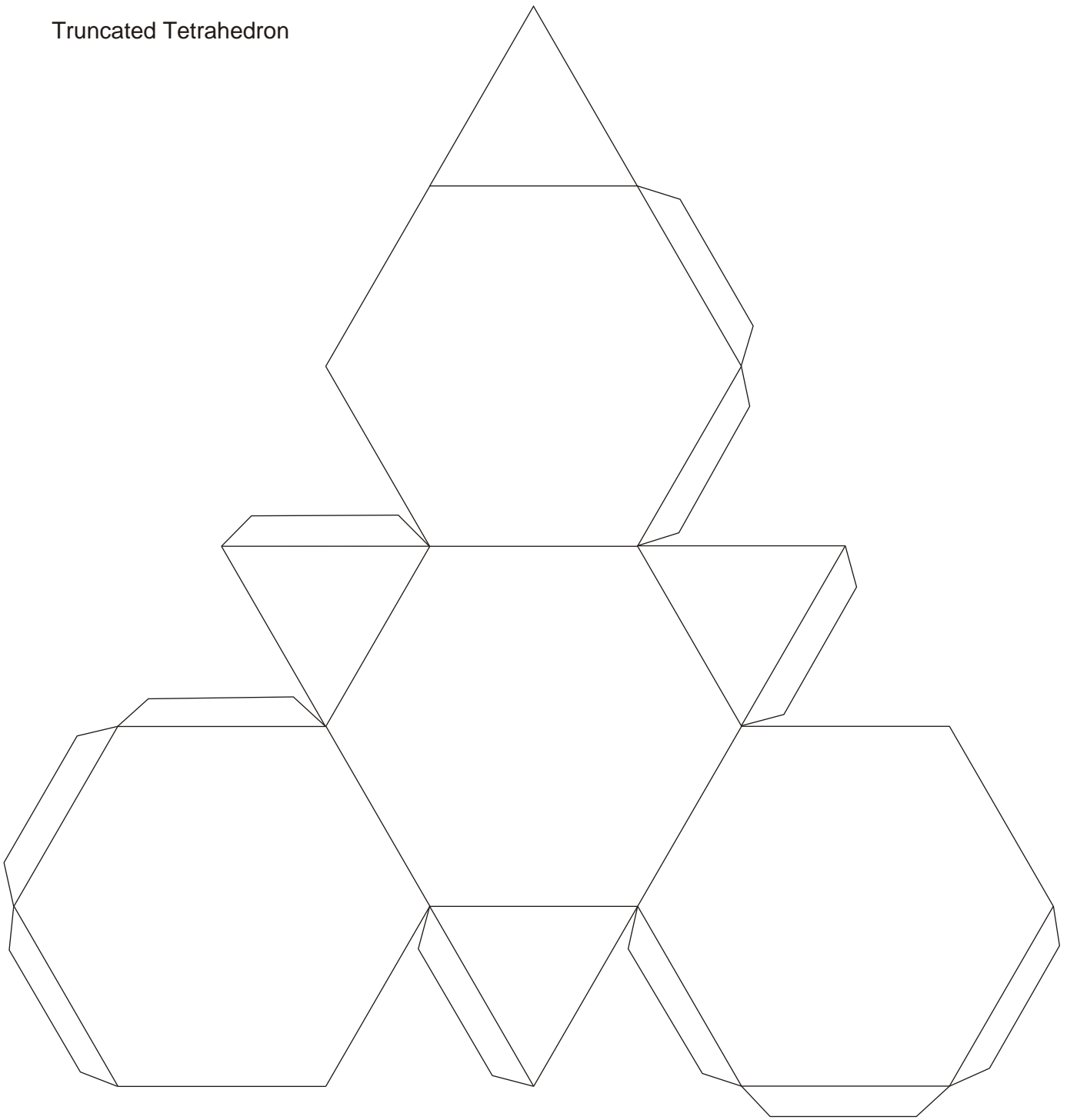

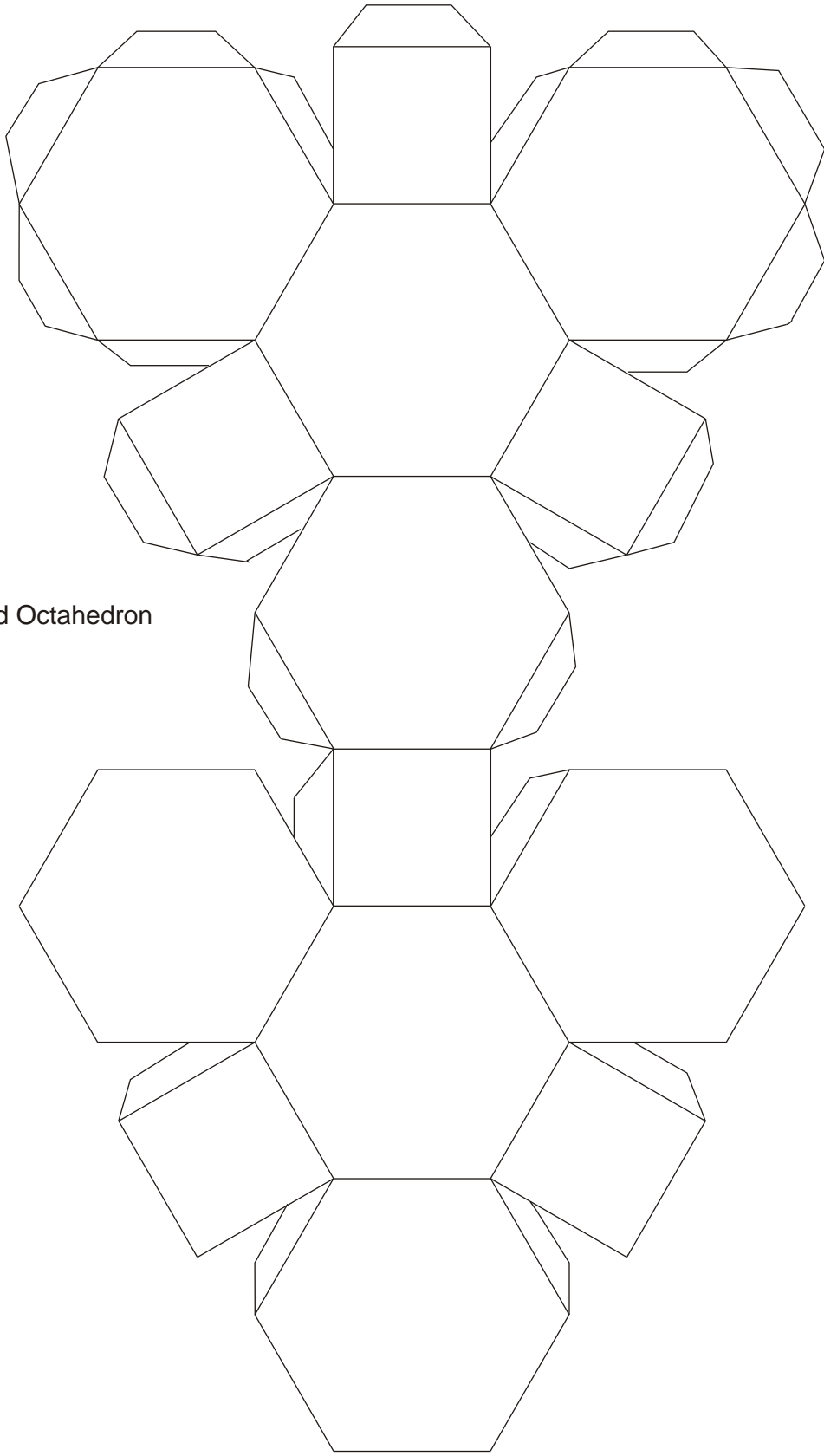

Truncated Octahedron

Truncated Cube

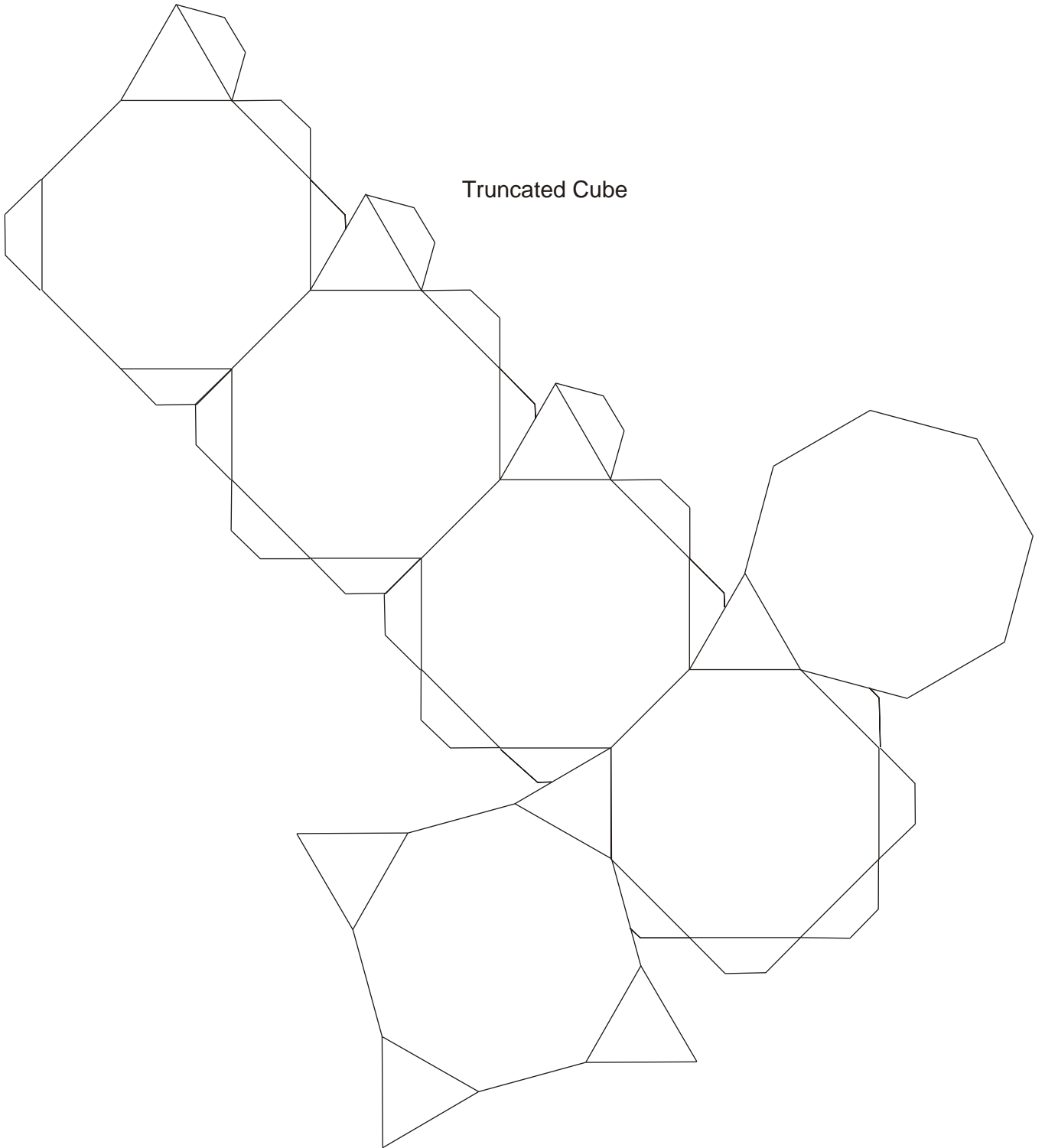



Truncated icosahedron

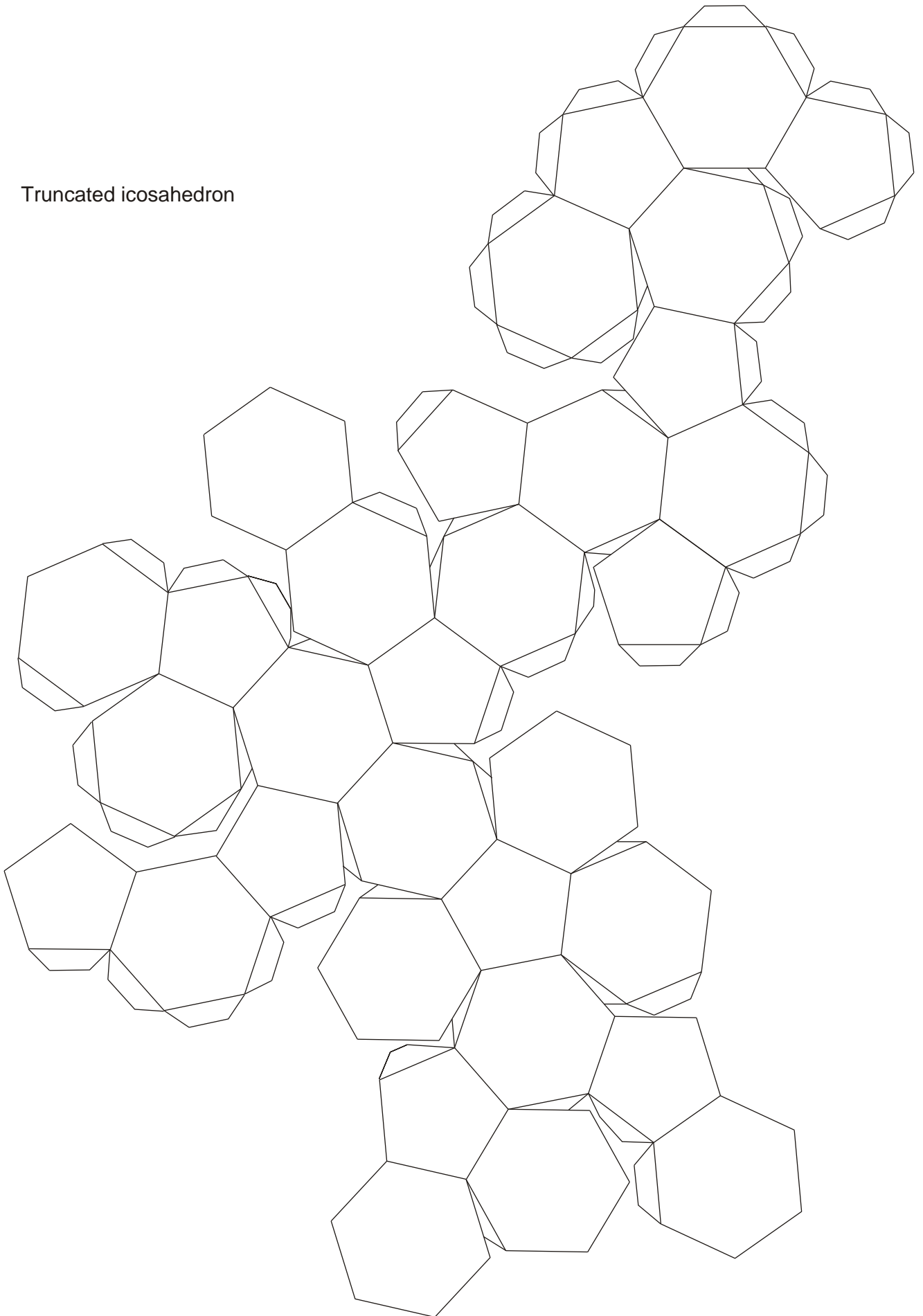

Truncated dodecahedron

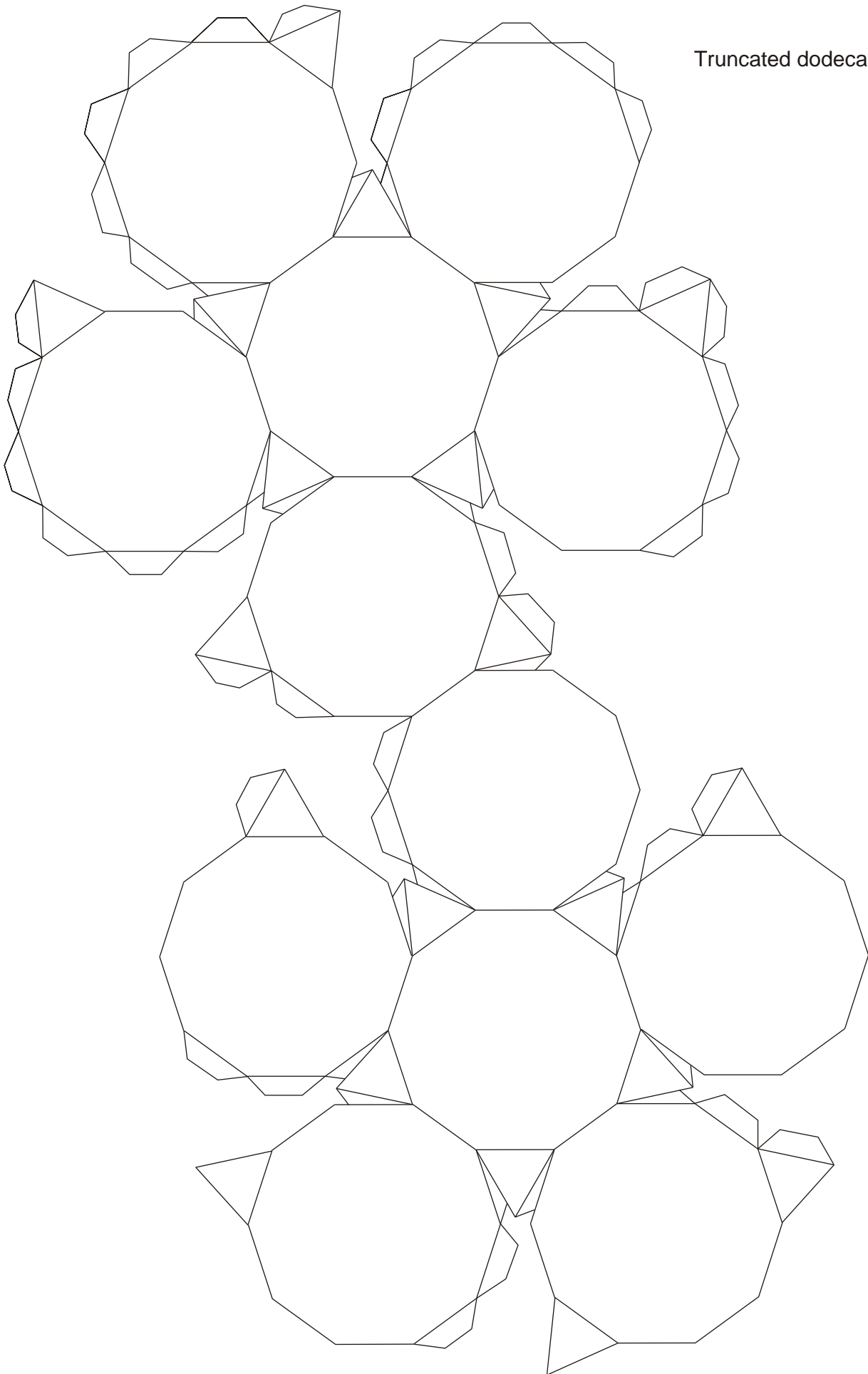

Rhombicuboctahedron

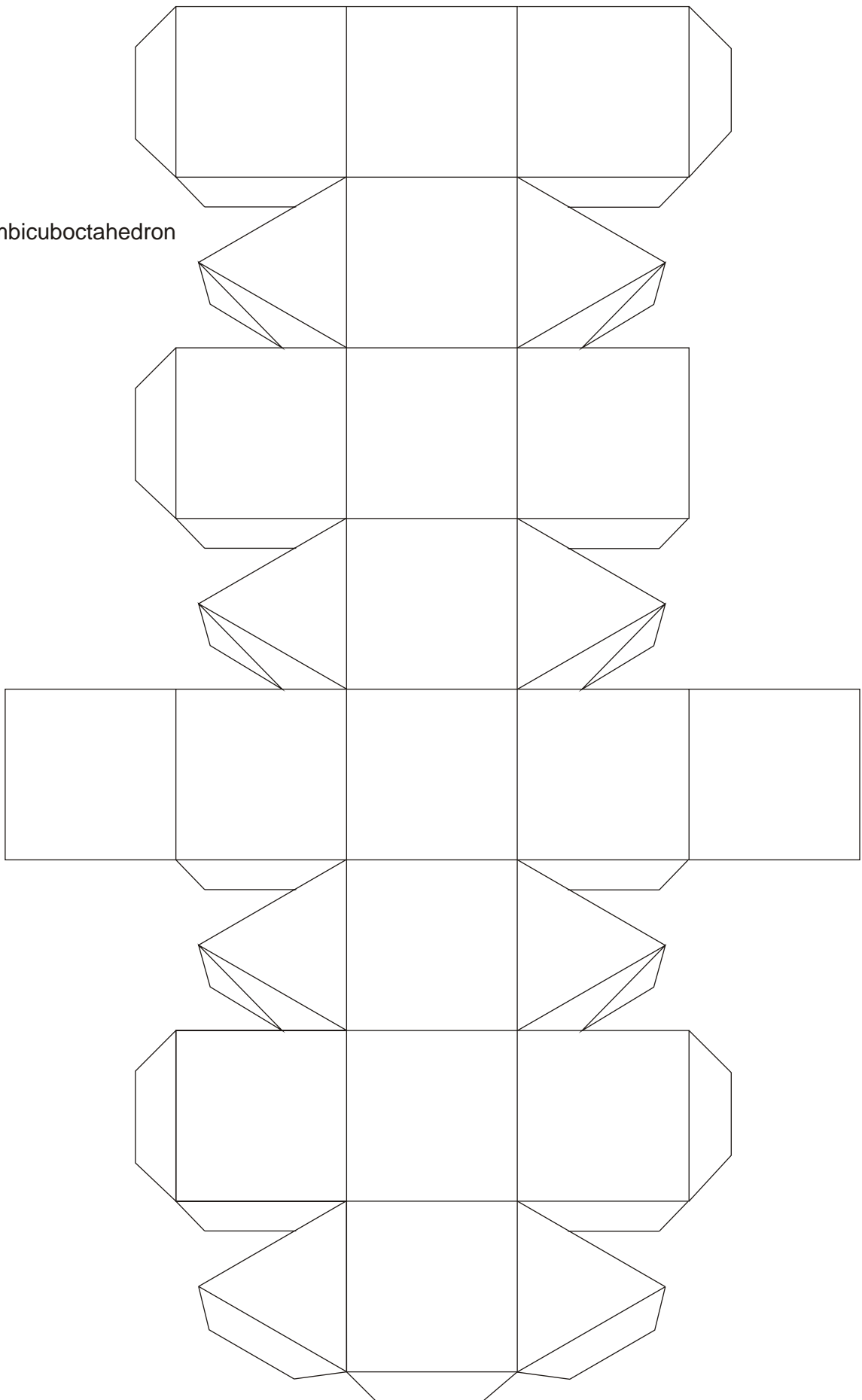

Truncated cuboctahedron

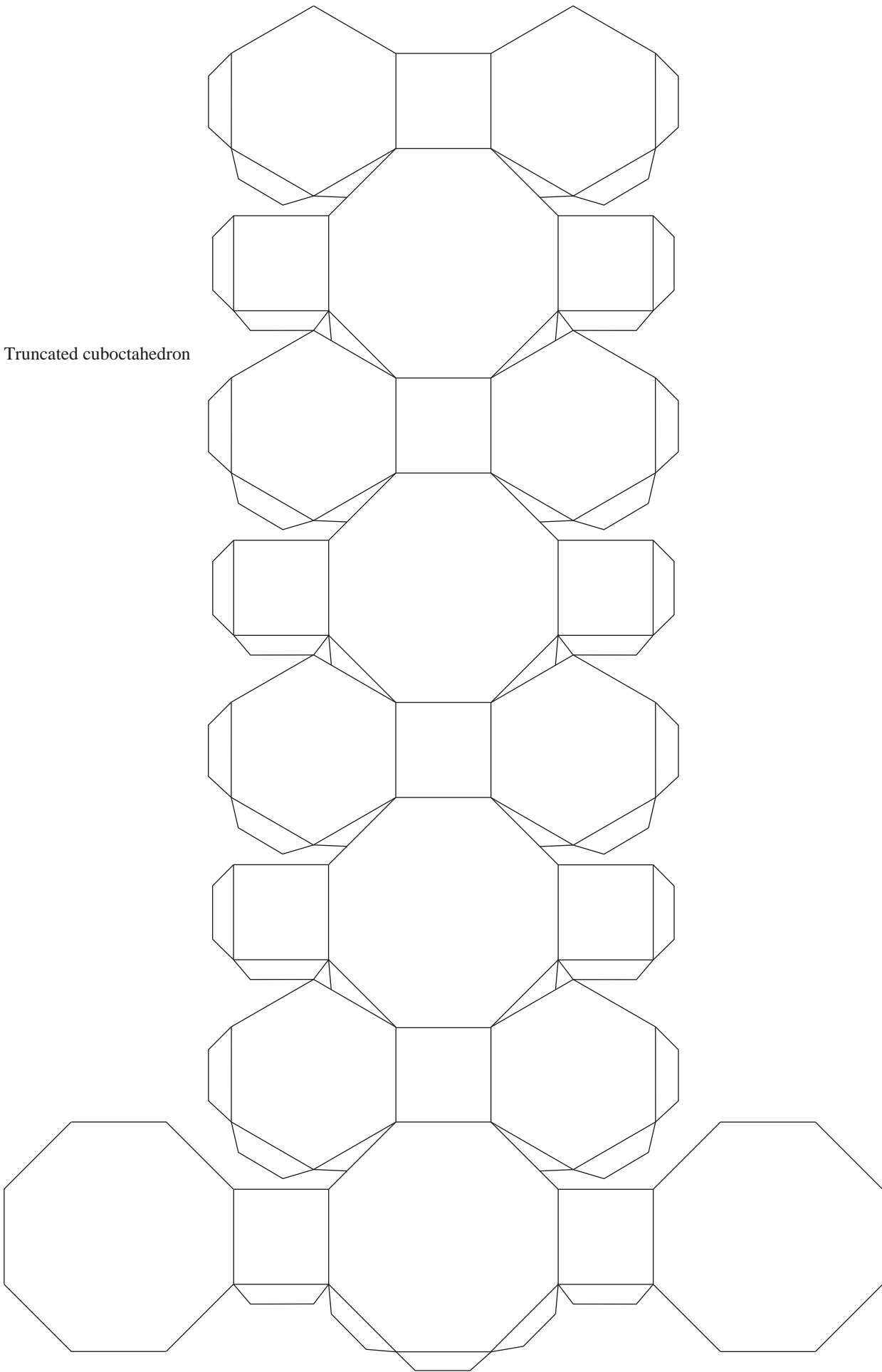

Rombicosidodecahedron

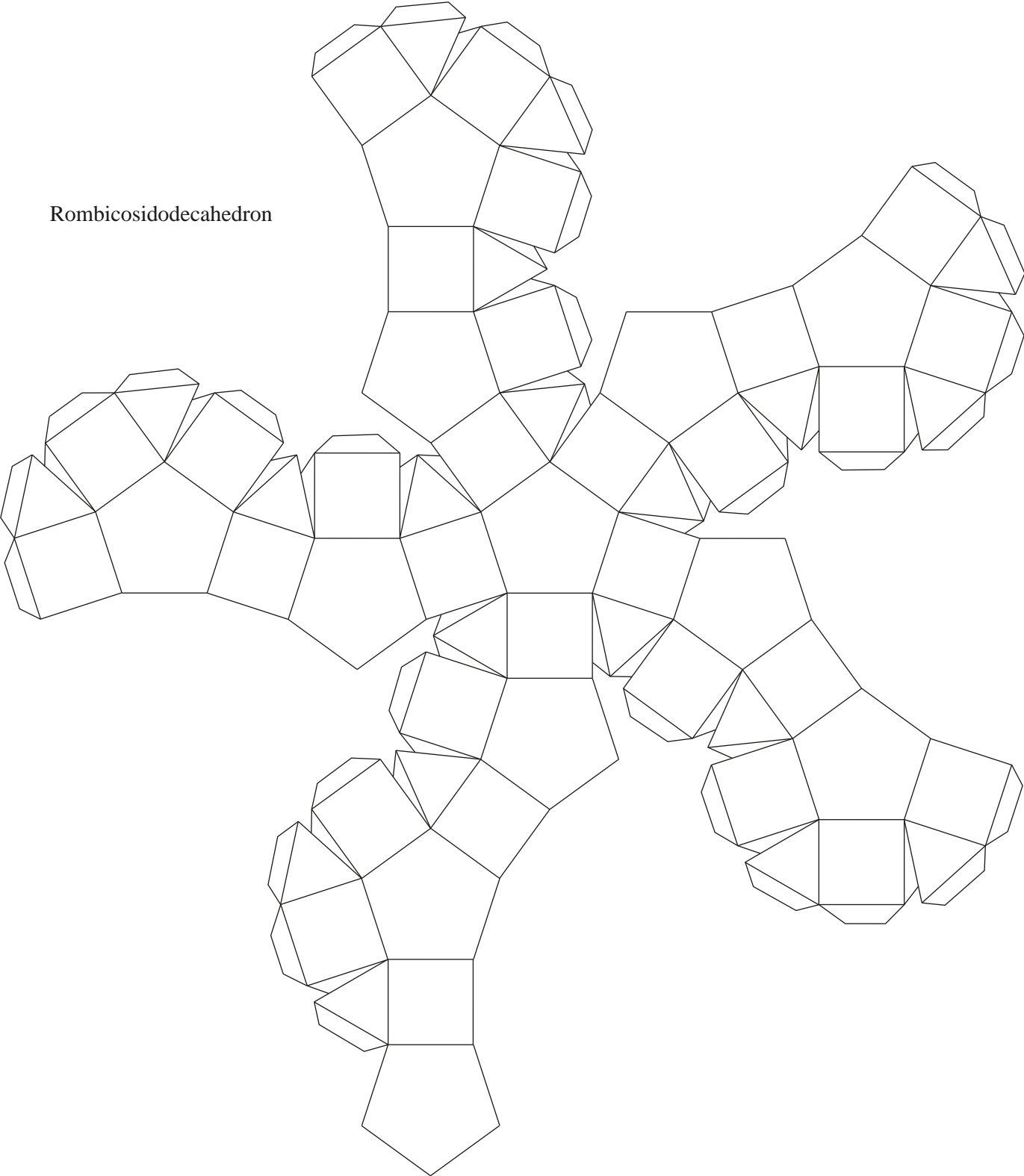

Truncated Icosidodecahedron

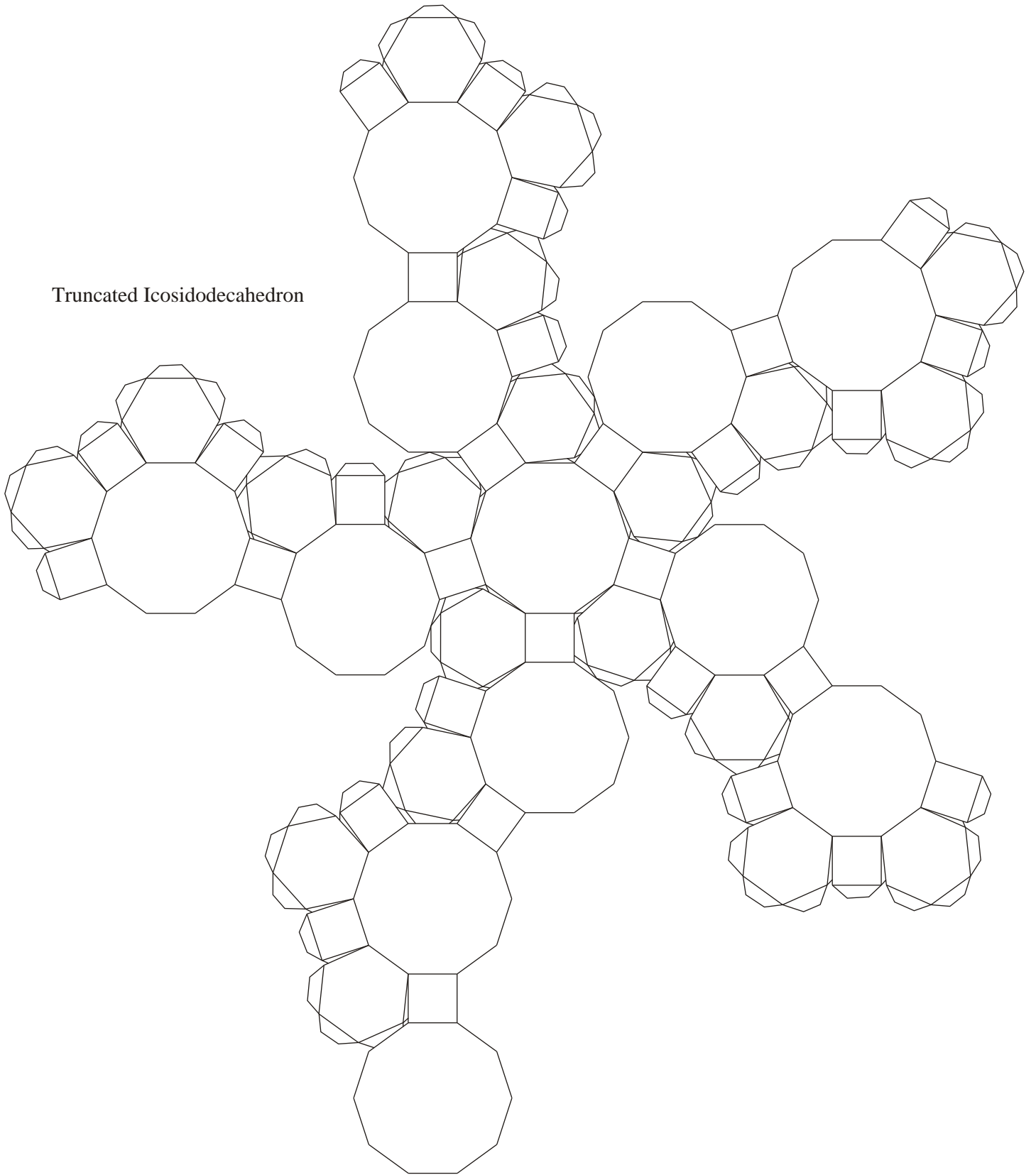

Snub cube

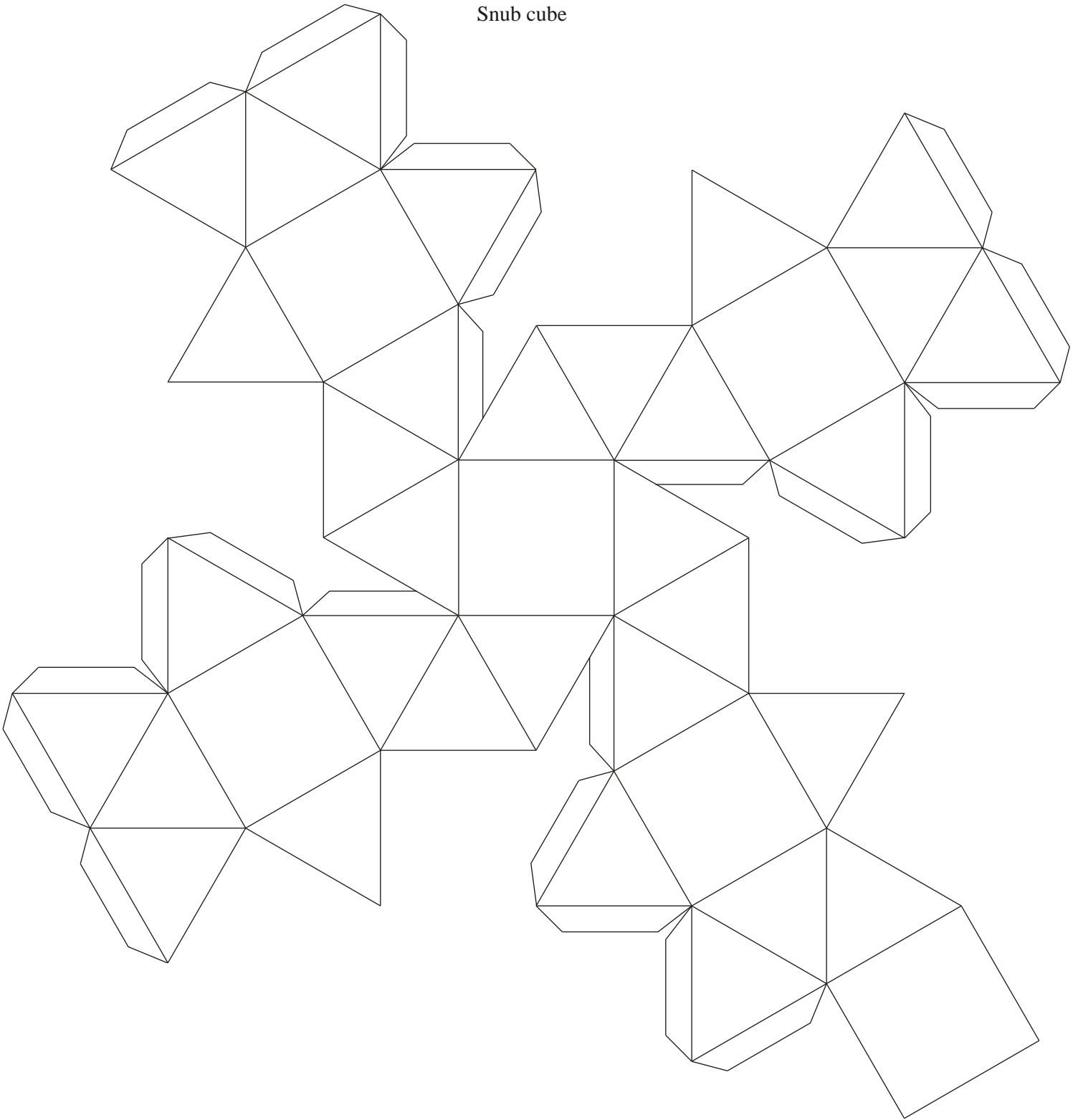

Snub cube  
Right-handed

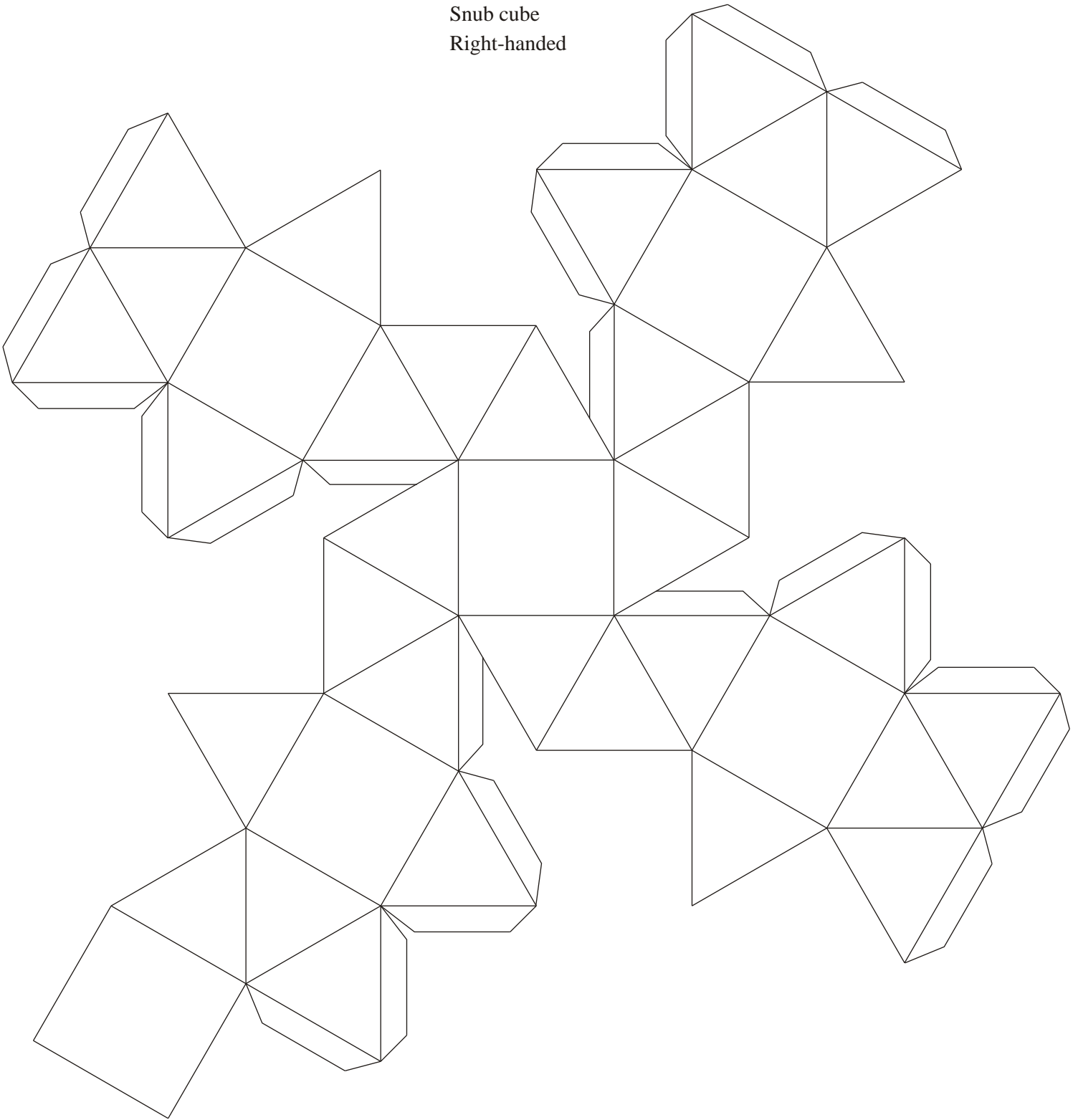



Snub dodecahedron

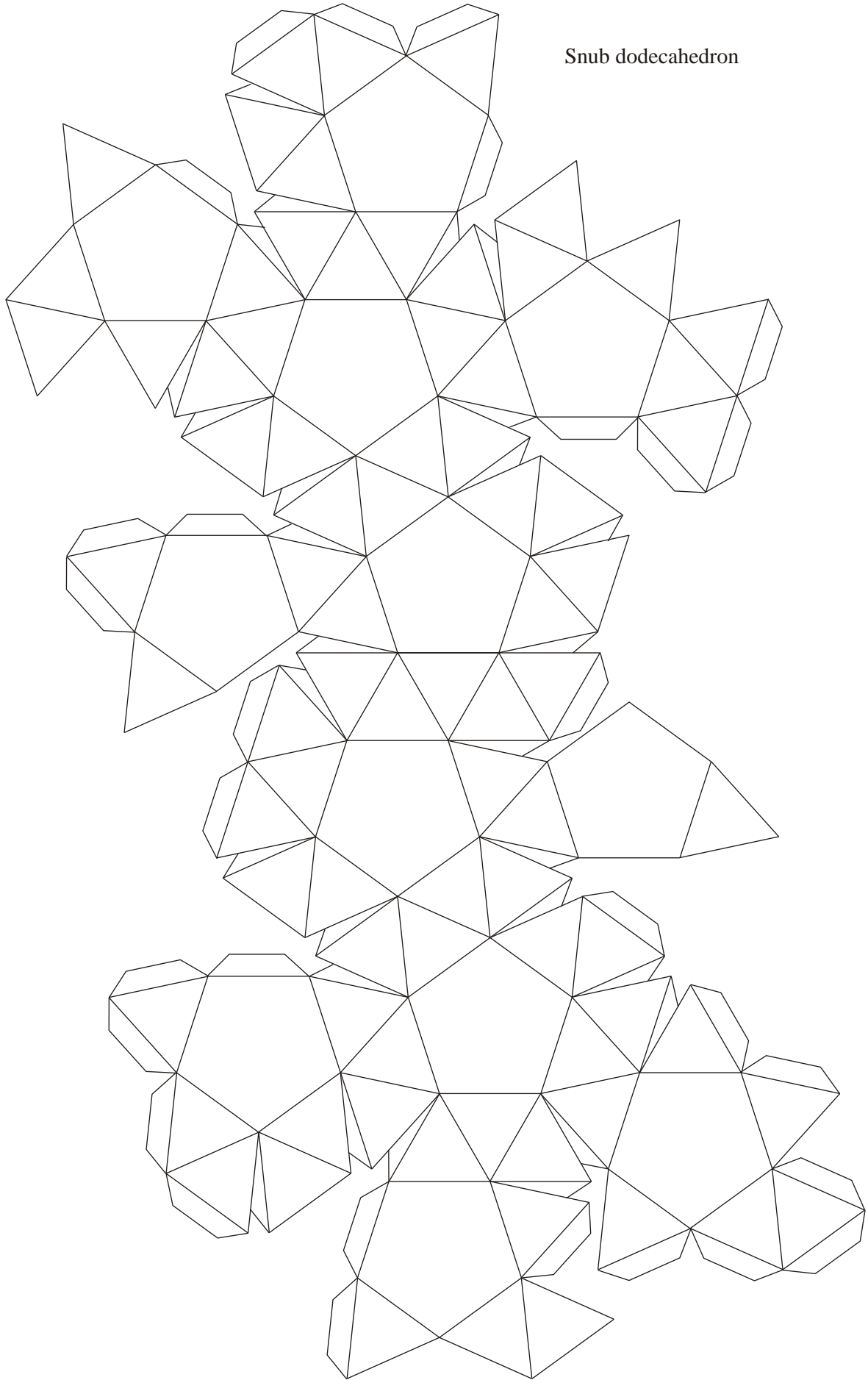

Snub dodecahedron  
Right-handed

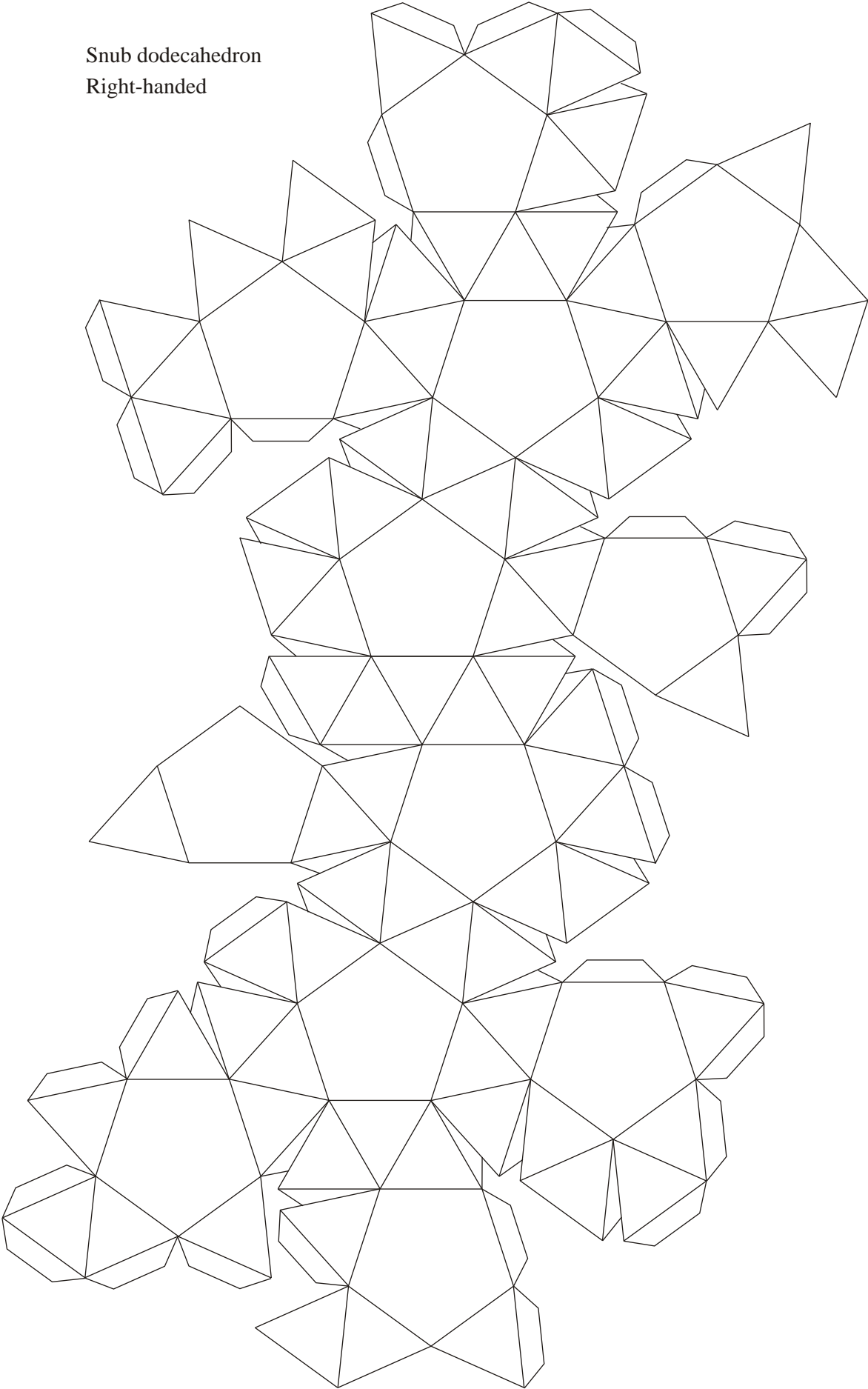

*Small Stellated Dodecahedron*

On this page a model out  
of one piece On the next pages  
a model out of six pieces.

Fold the long lines backwards  
fold the short lines forwards

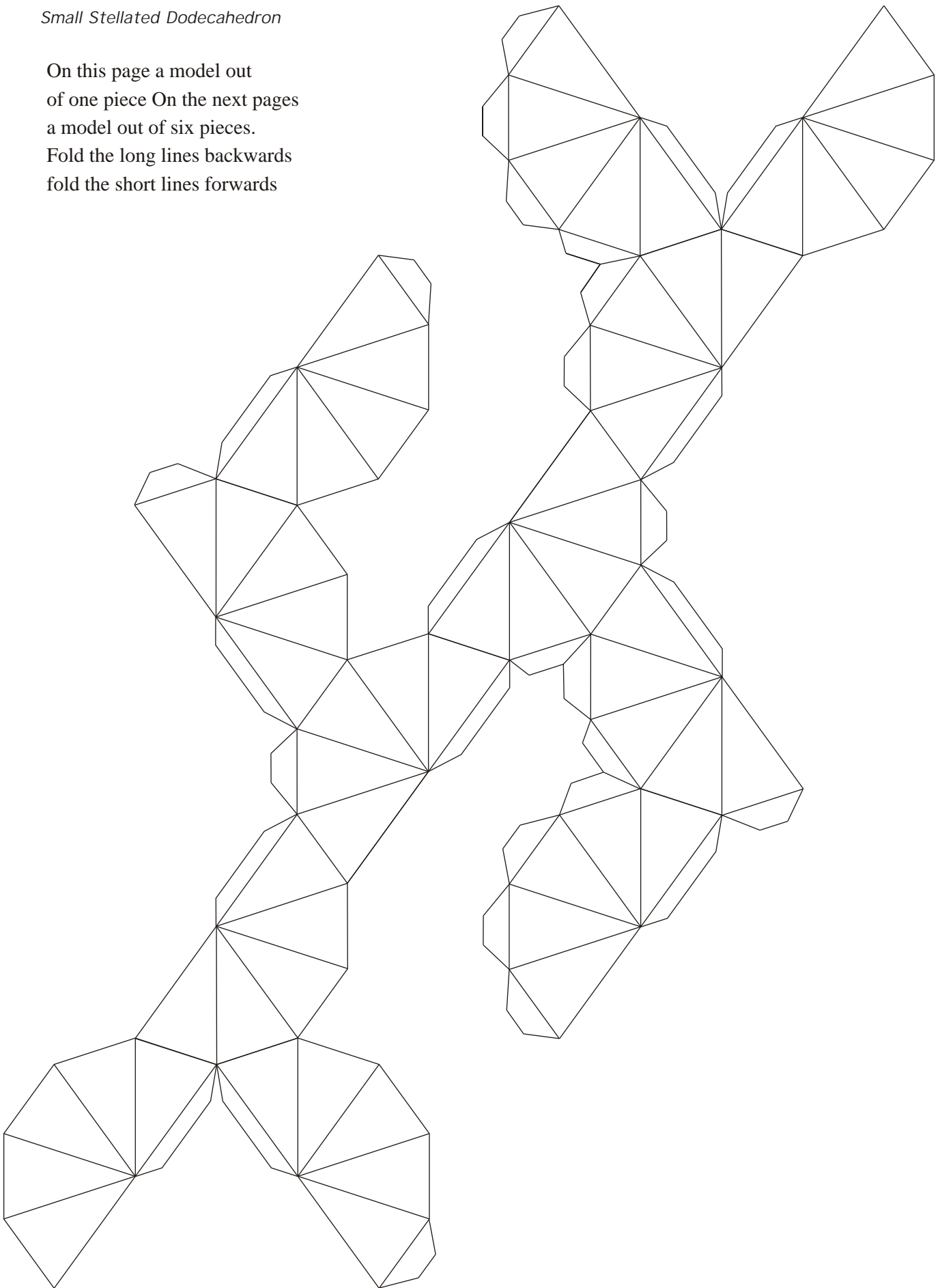

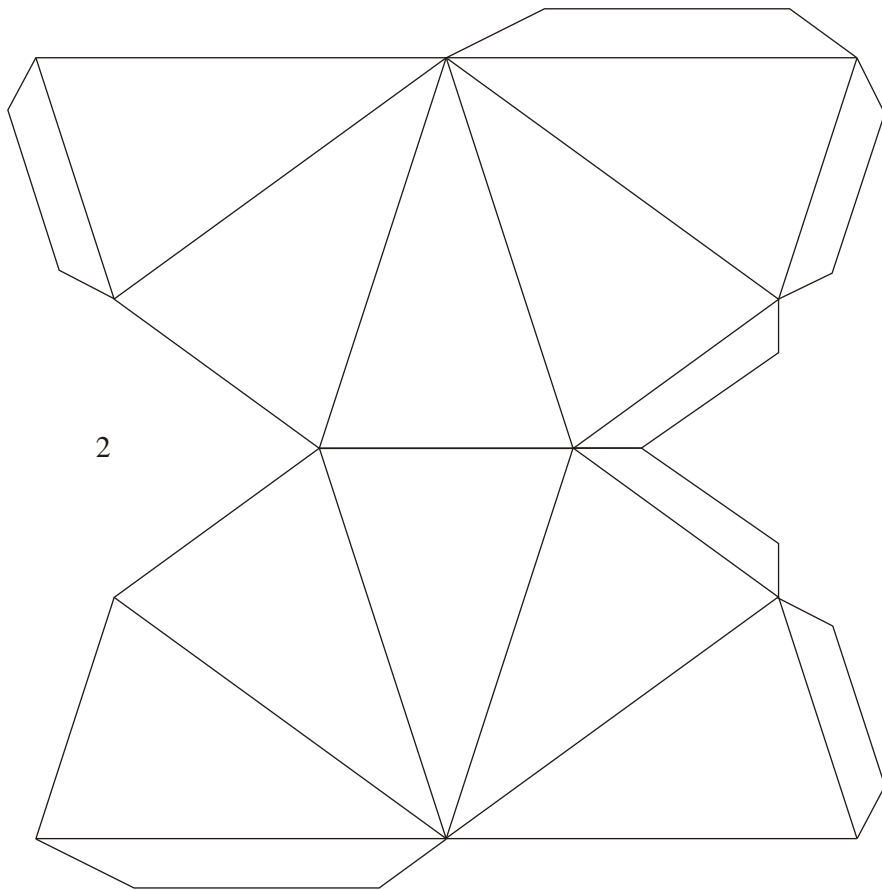
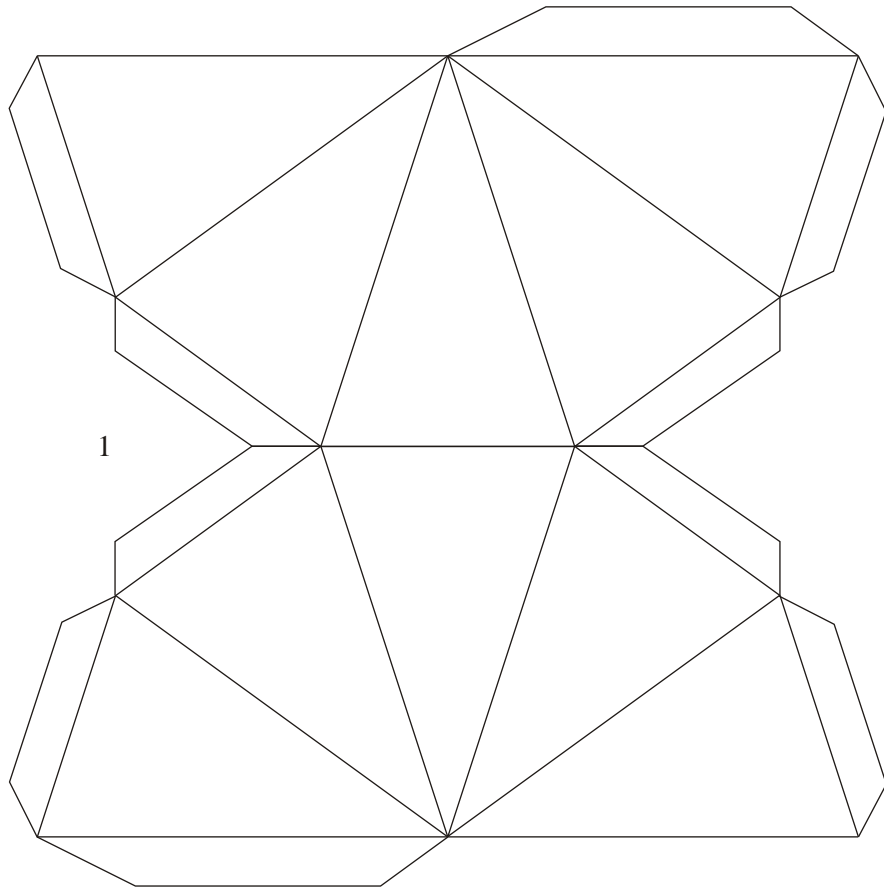

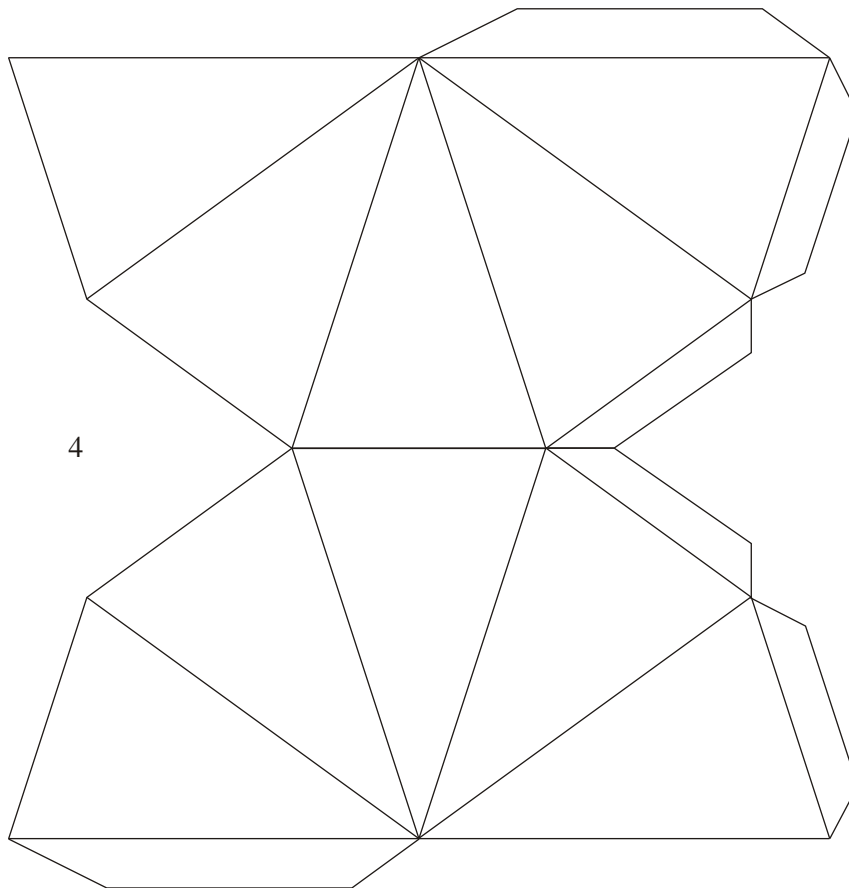
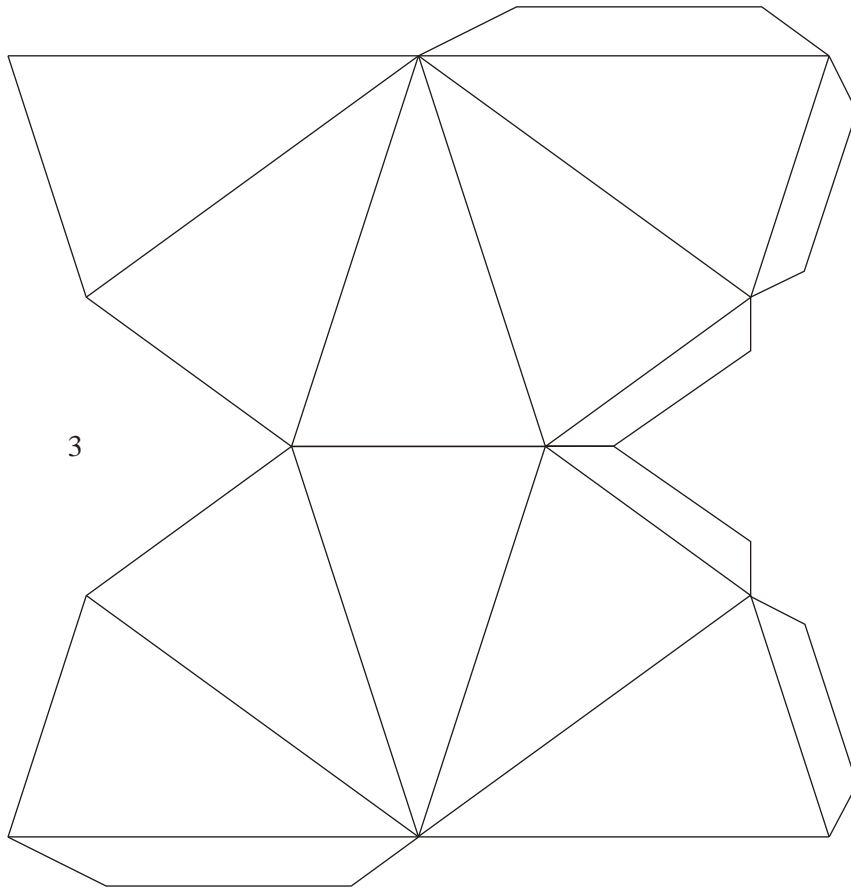

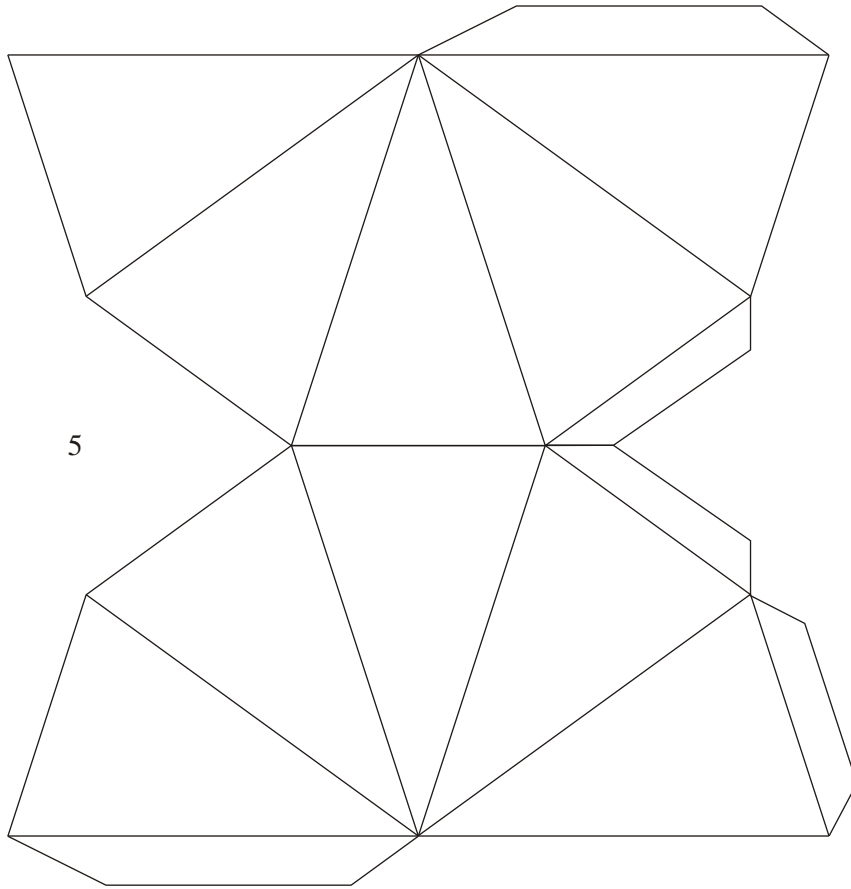

5

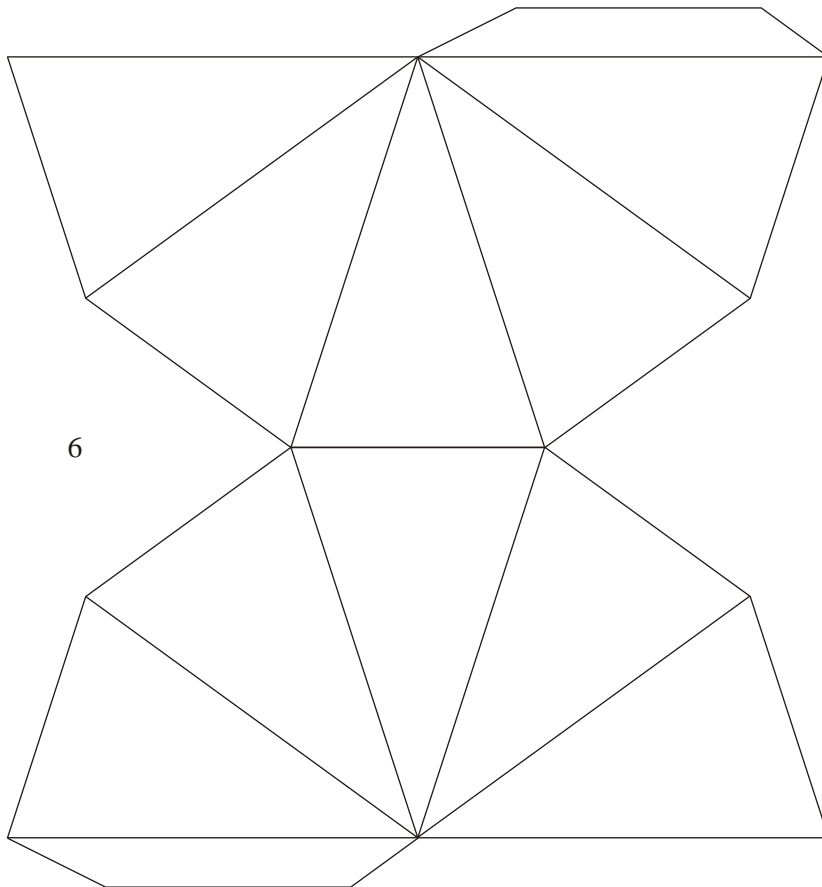

6

# Octahemioctahedron

----- type 1  
----- type 2

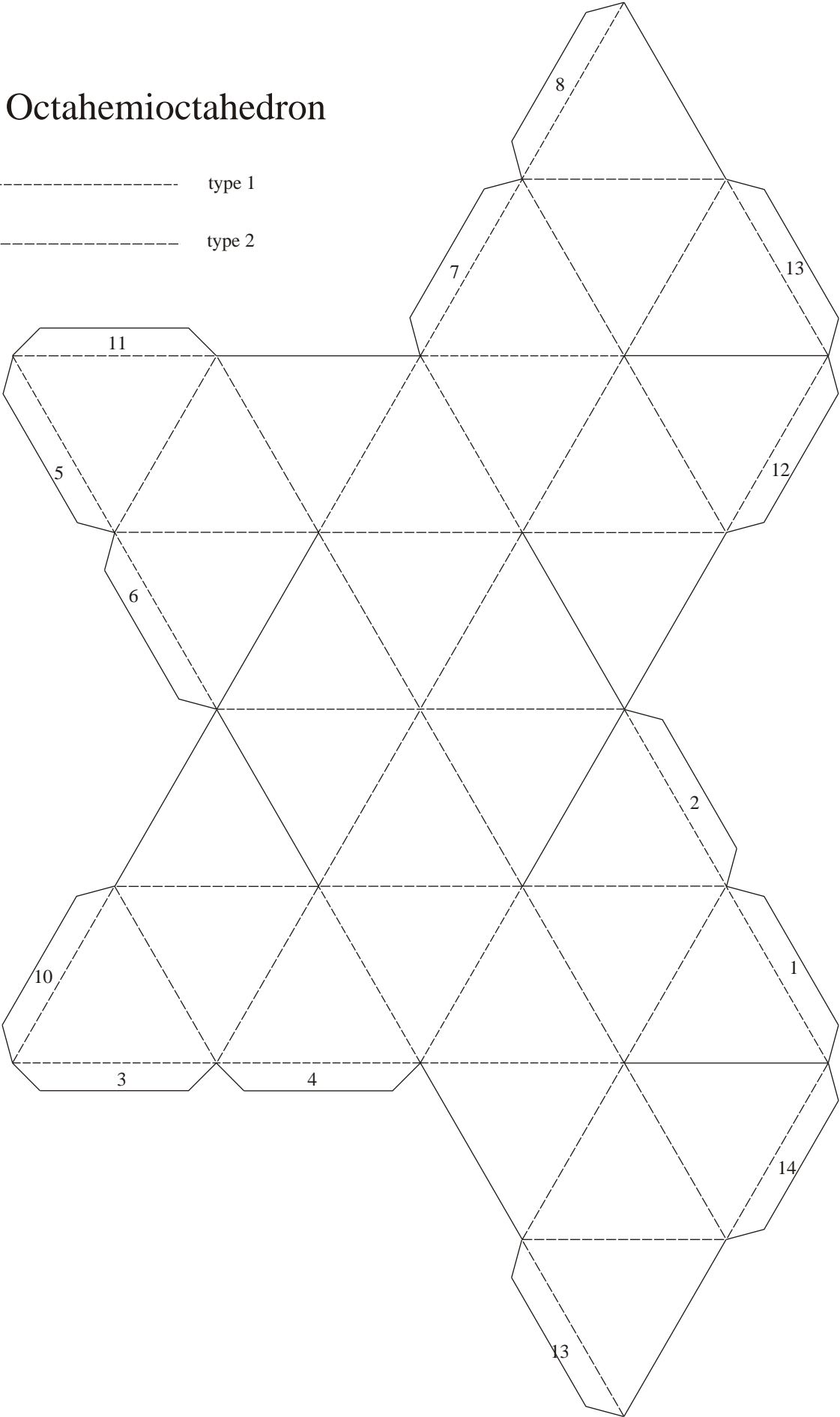

*Cubohemioctahedron*

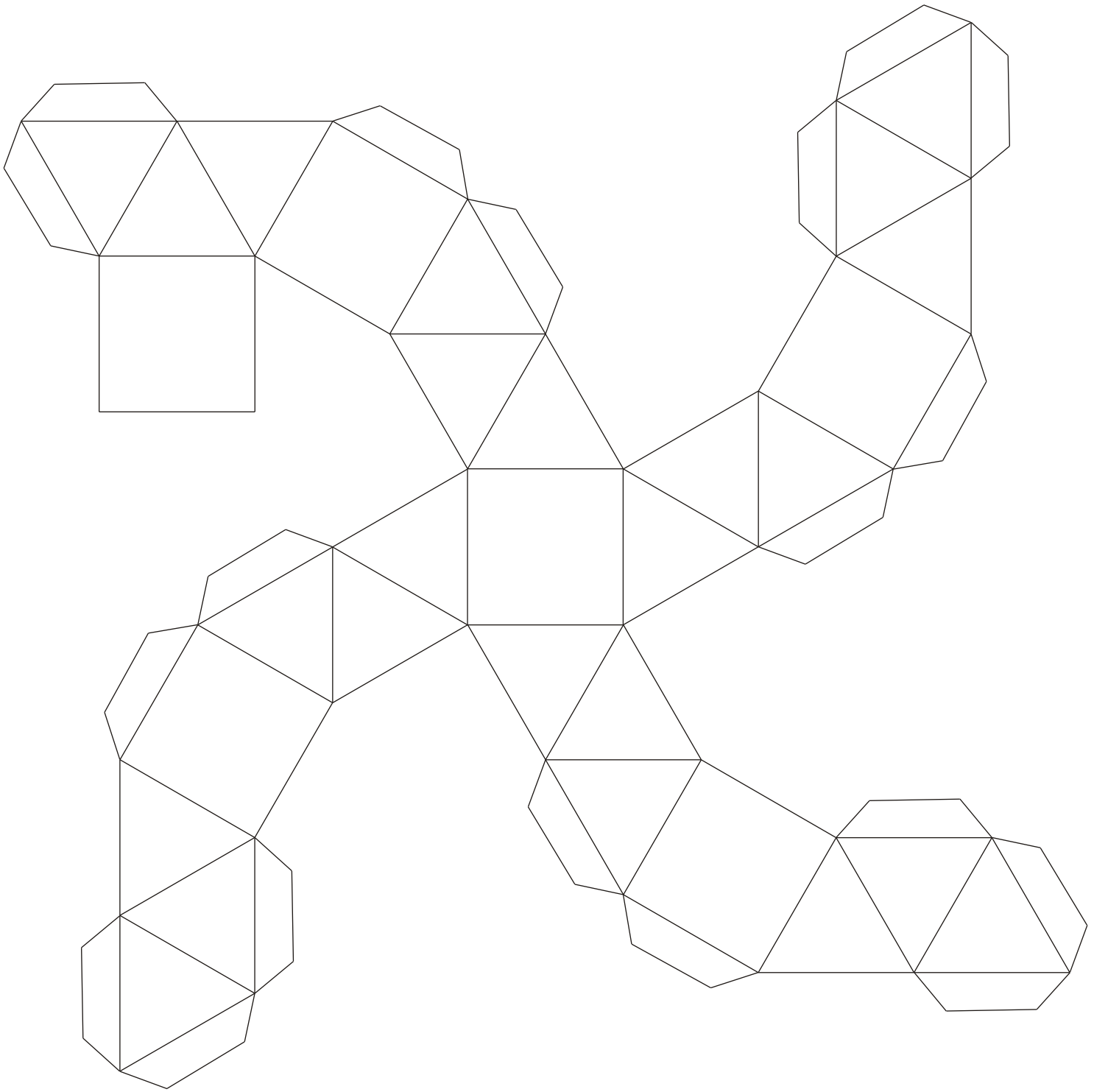



## Small Rhombidodecahedron

(small version)

Fold the dotted lines forwards

Fold the other lines

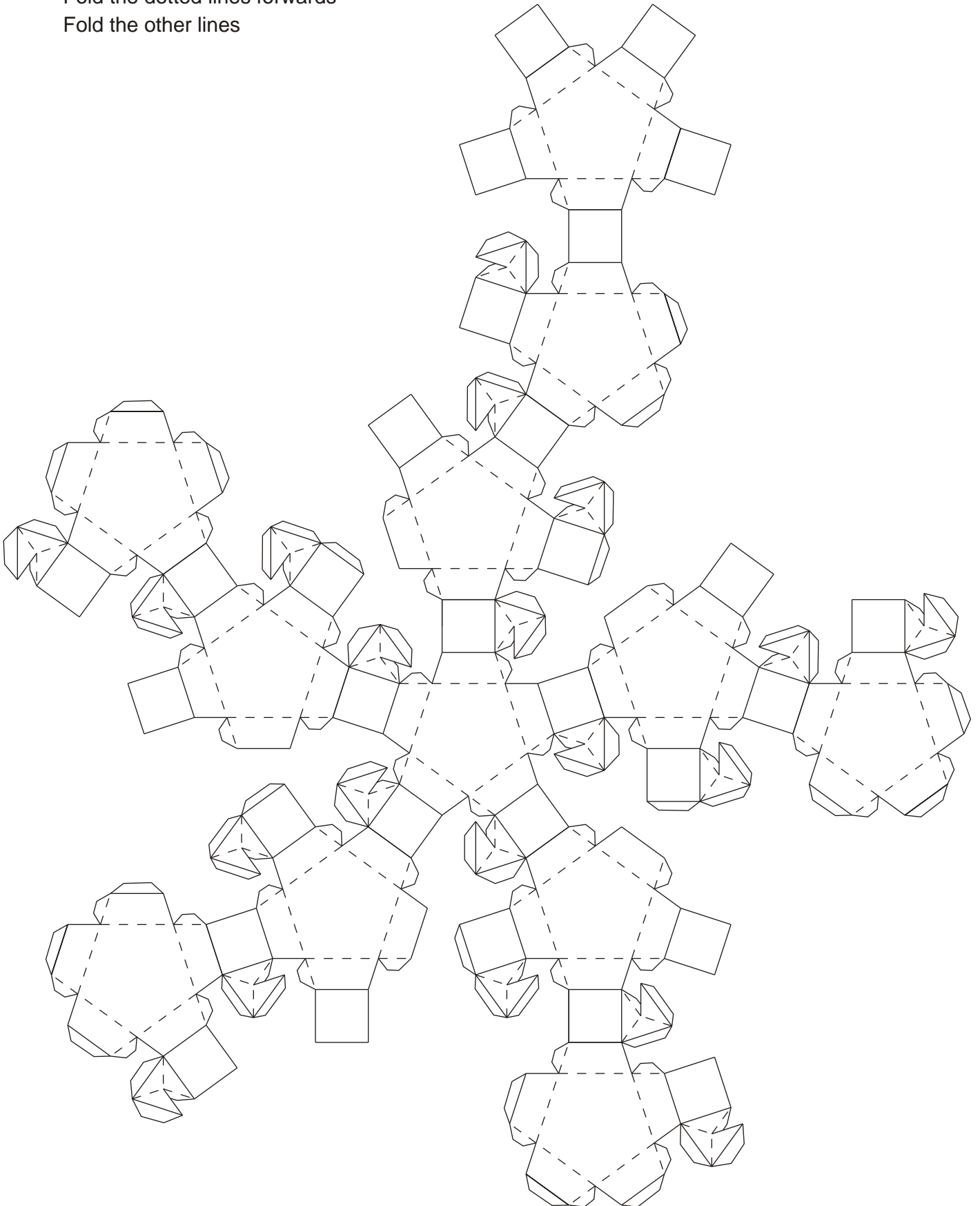

# Small Rhombidodecahedron

(large version)

Fold the dotted lines forwards

Fold the other lines

## A

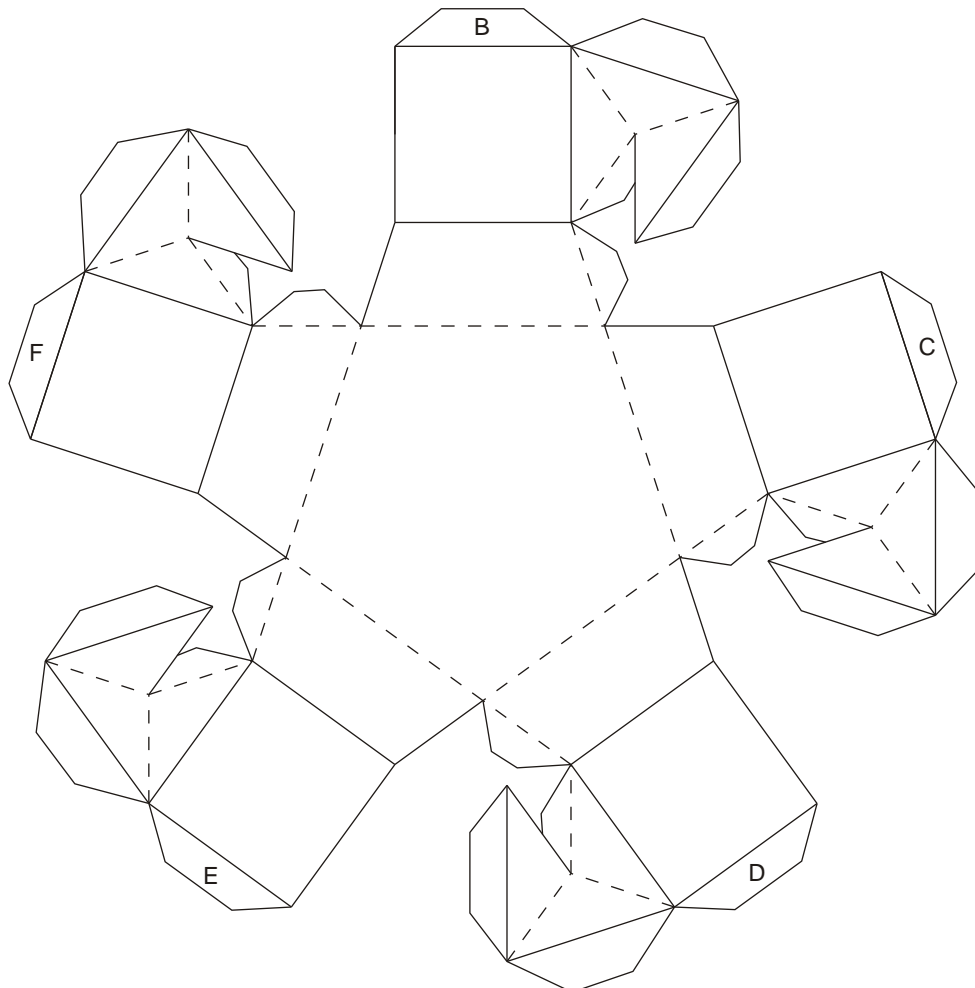

B

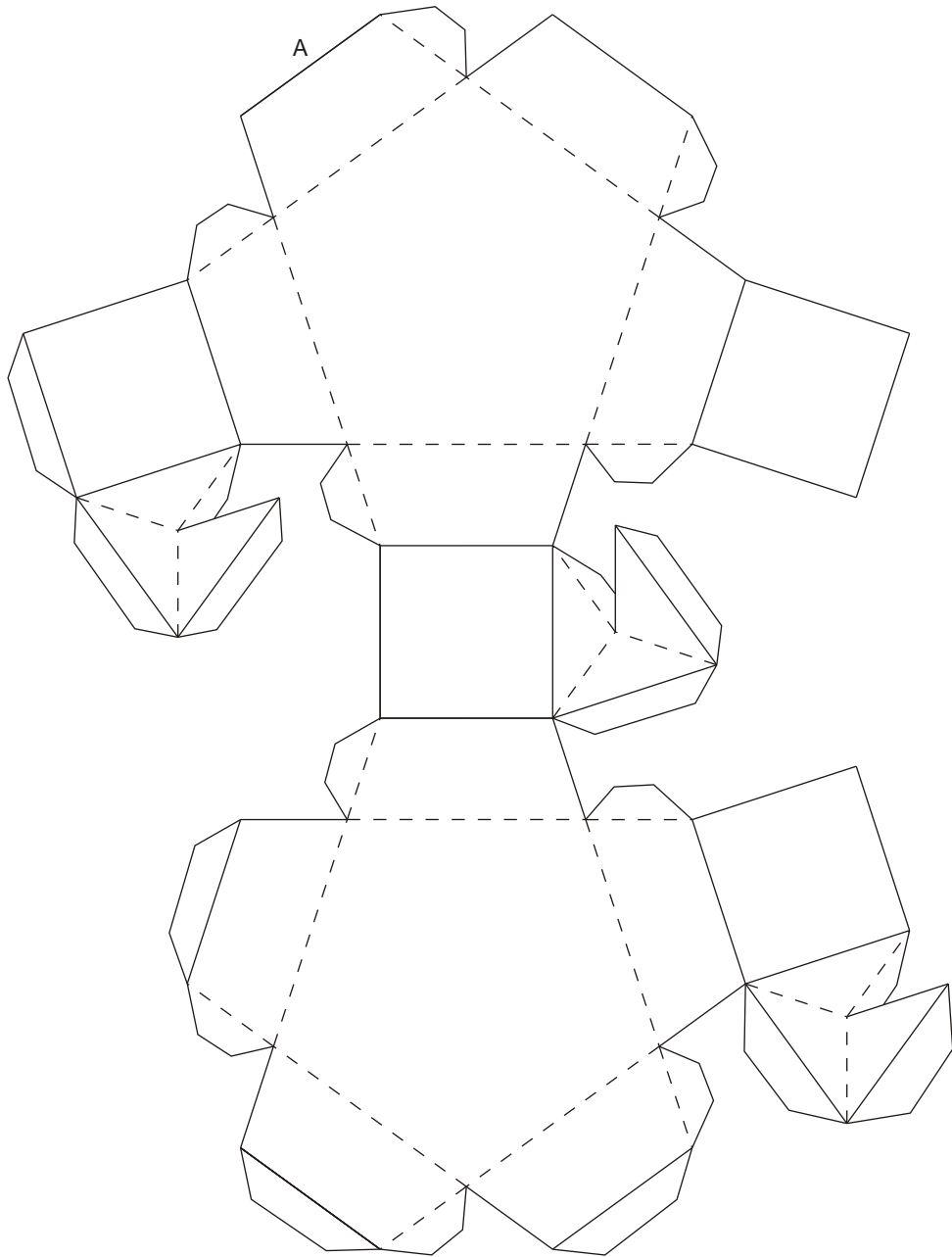

C

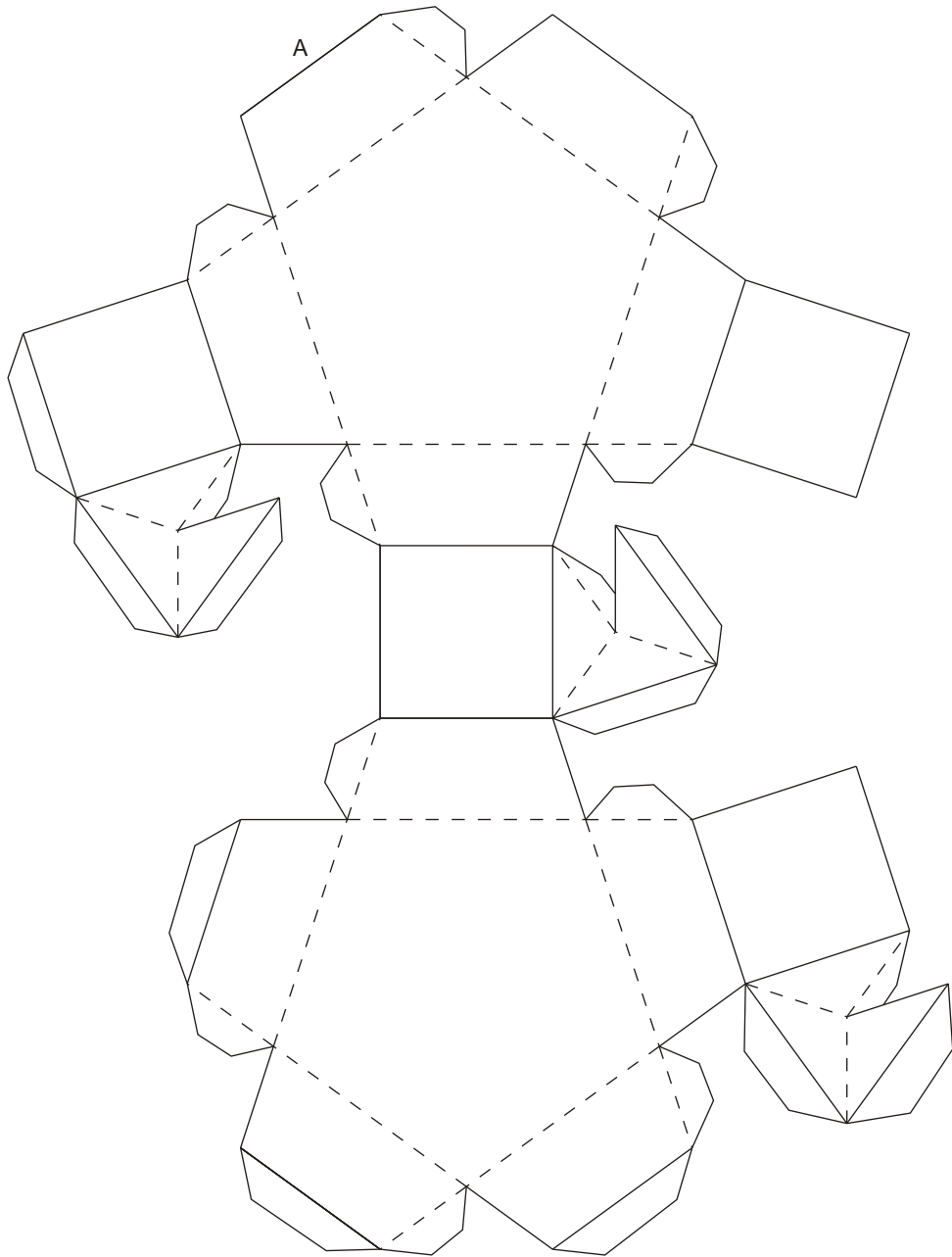

D

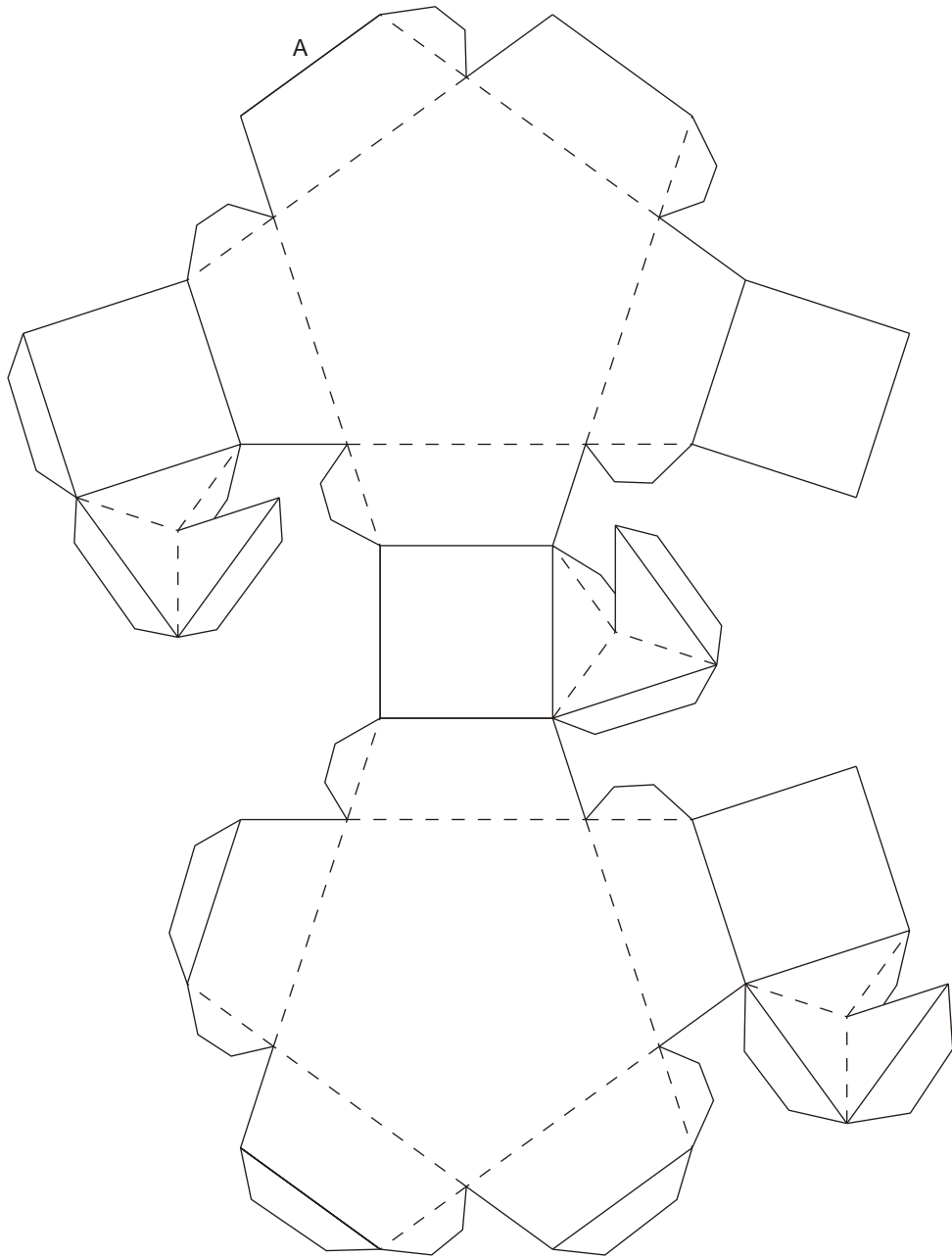

E

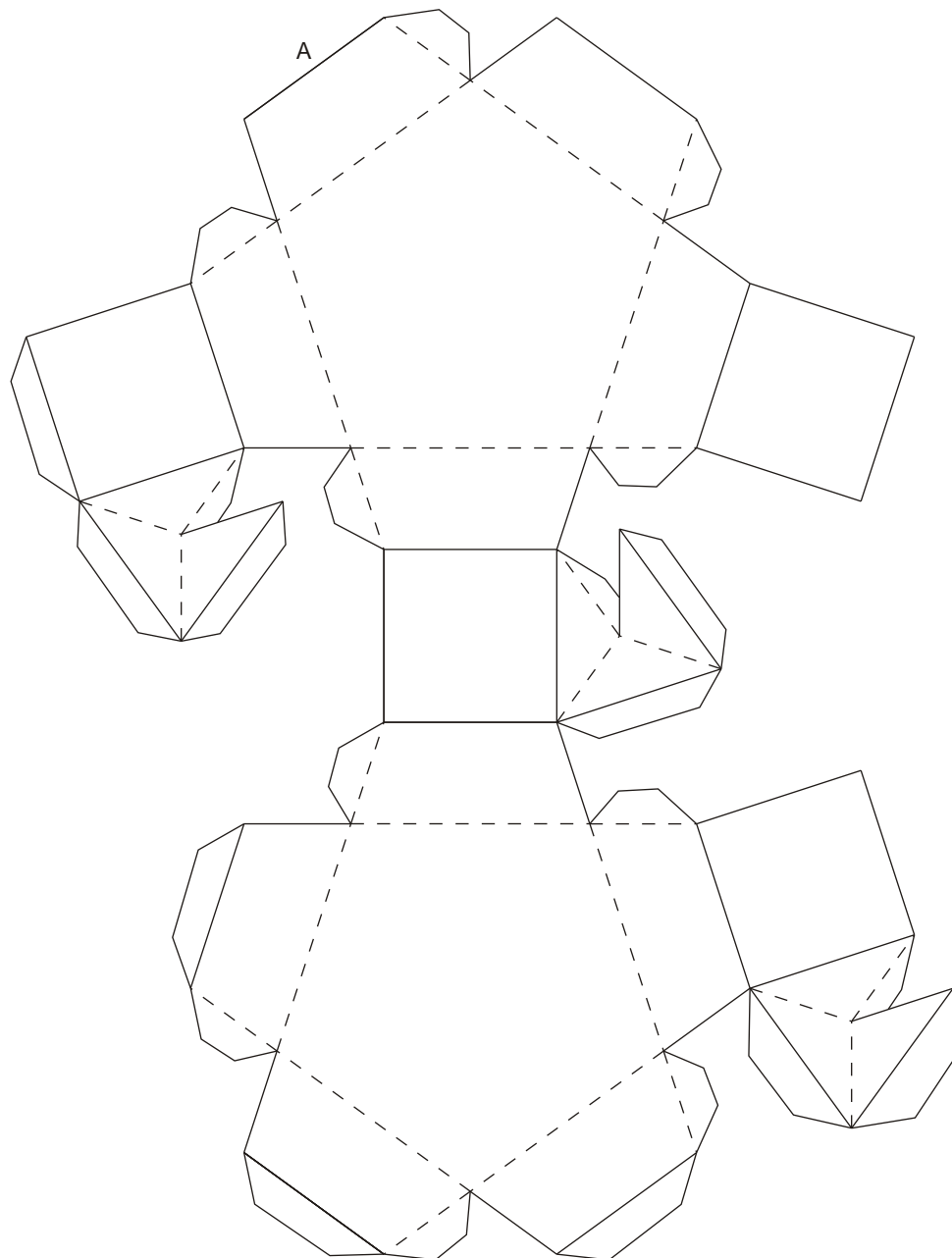

**F**

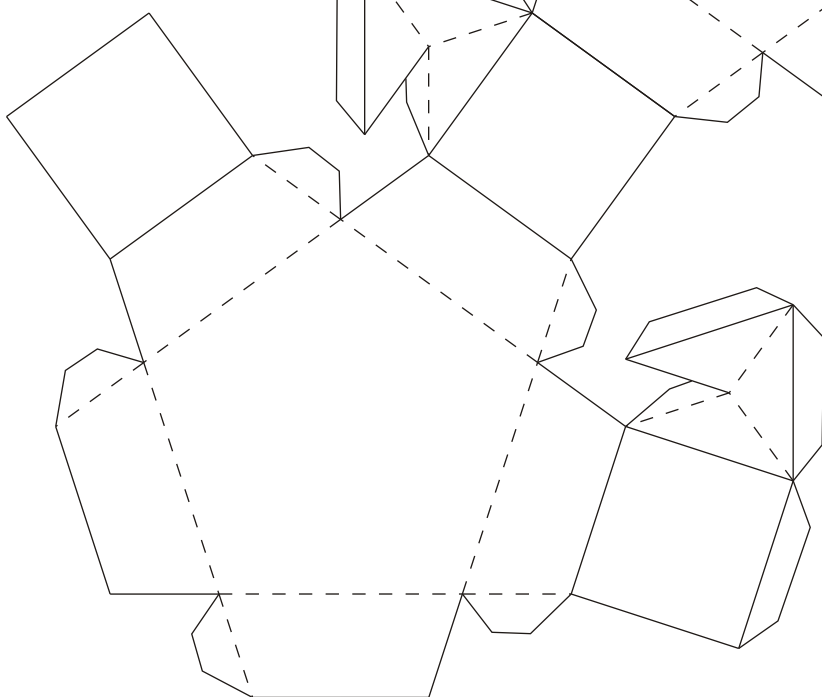
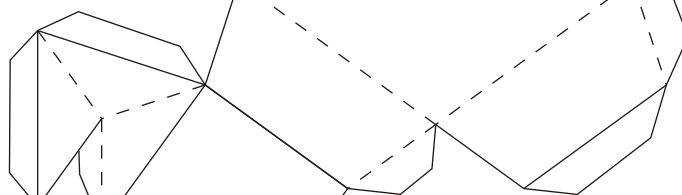
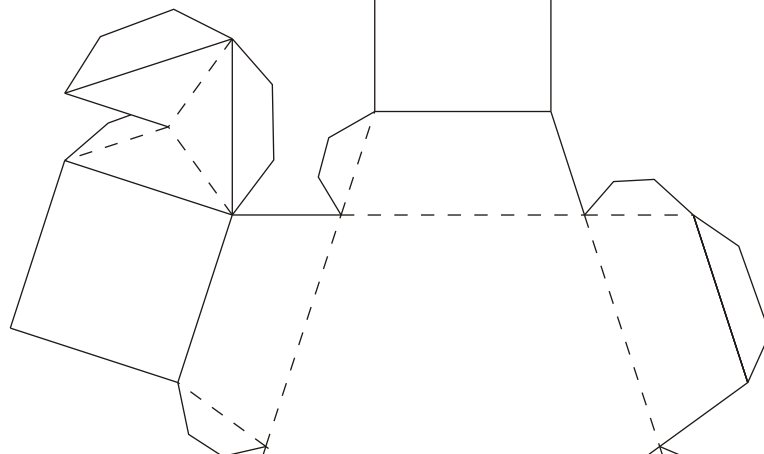
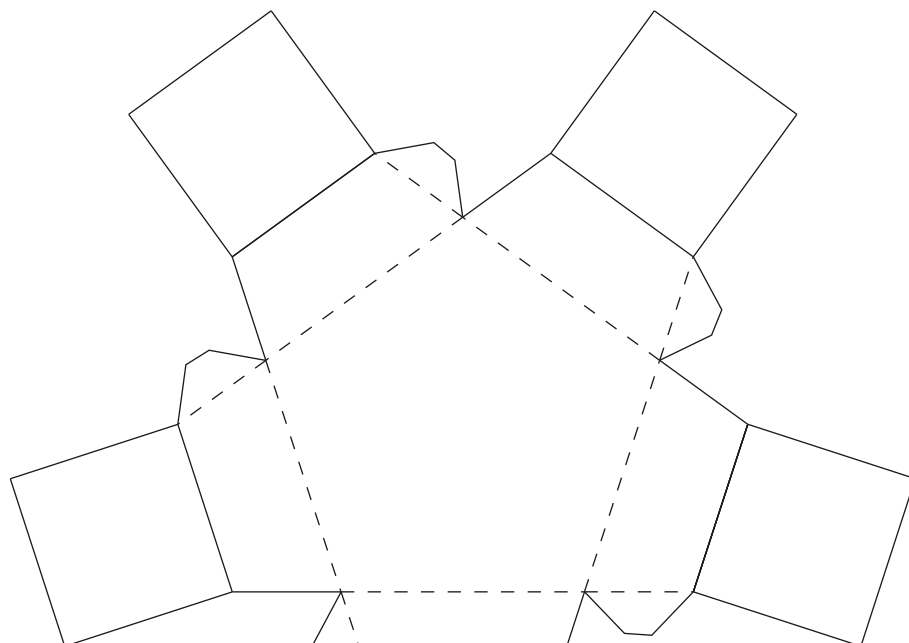

**A**

*Small dodecahemidodecahedron*

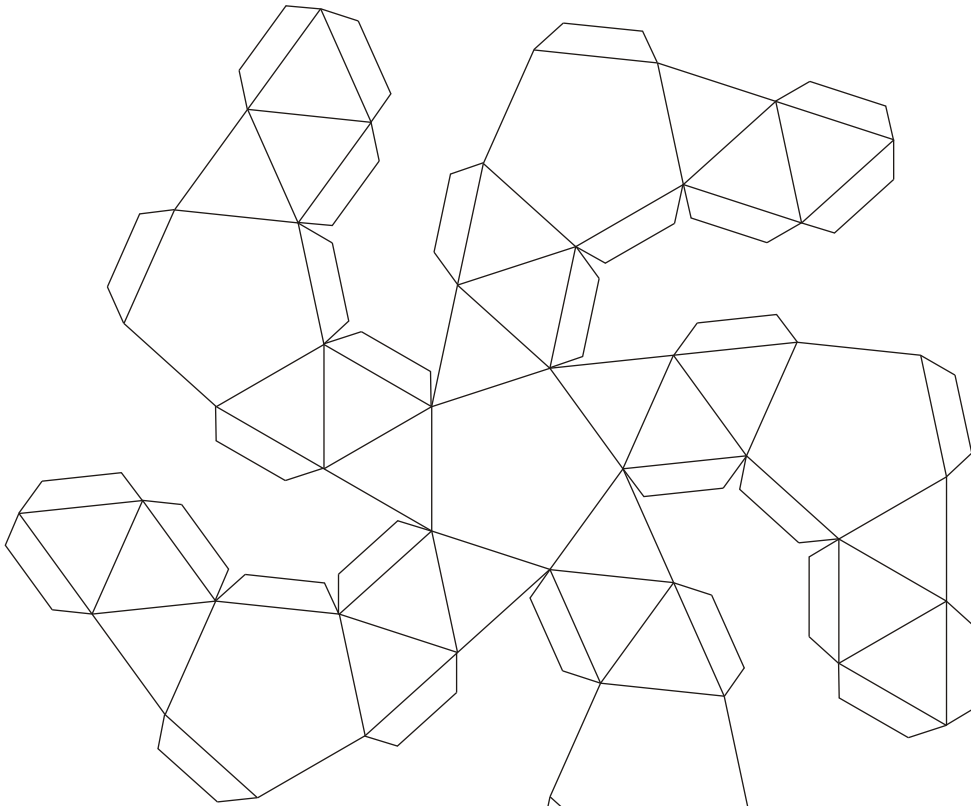

*Folds the lines between the triangles forwards. Folds the other lines backwards.*

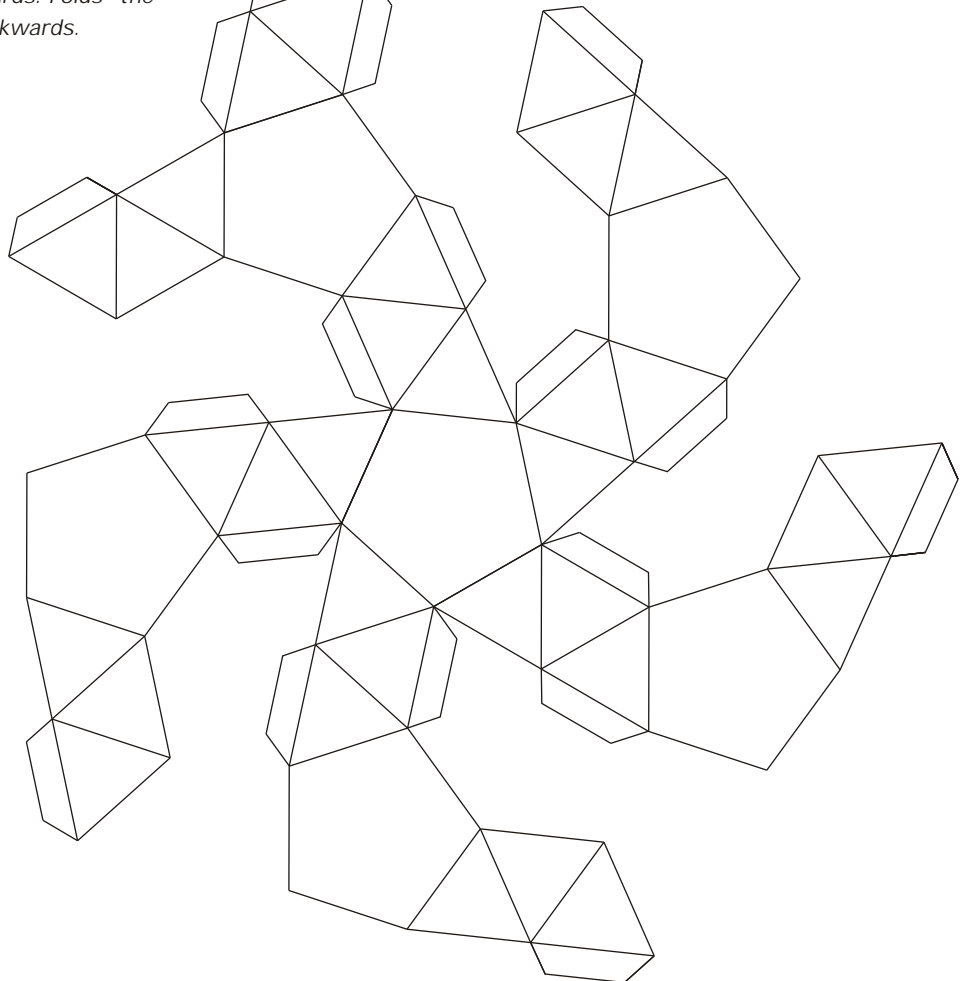



*Great Stellated Dodecahedron  
made out of one piece of paper.  
Cut the lines between the long  
and the short sides of the triangles.  
Fold the long lines backwards and  
fold the short lines forwards.*

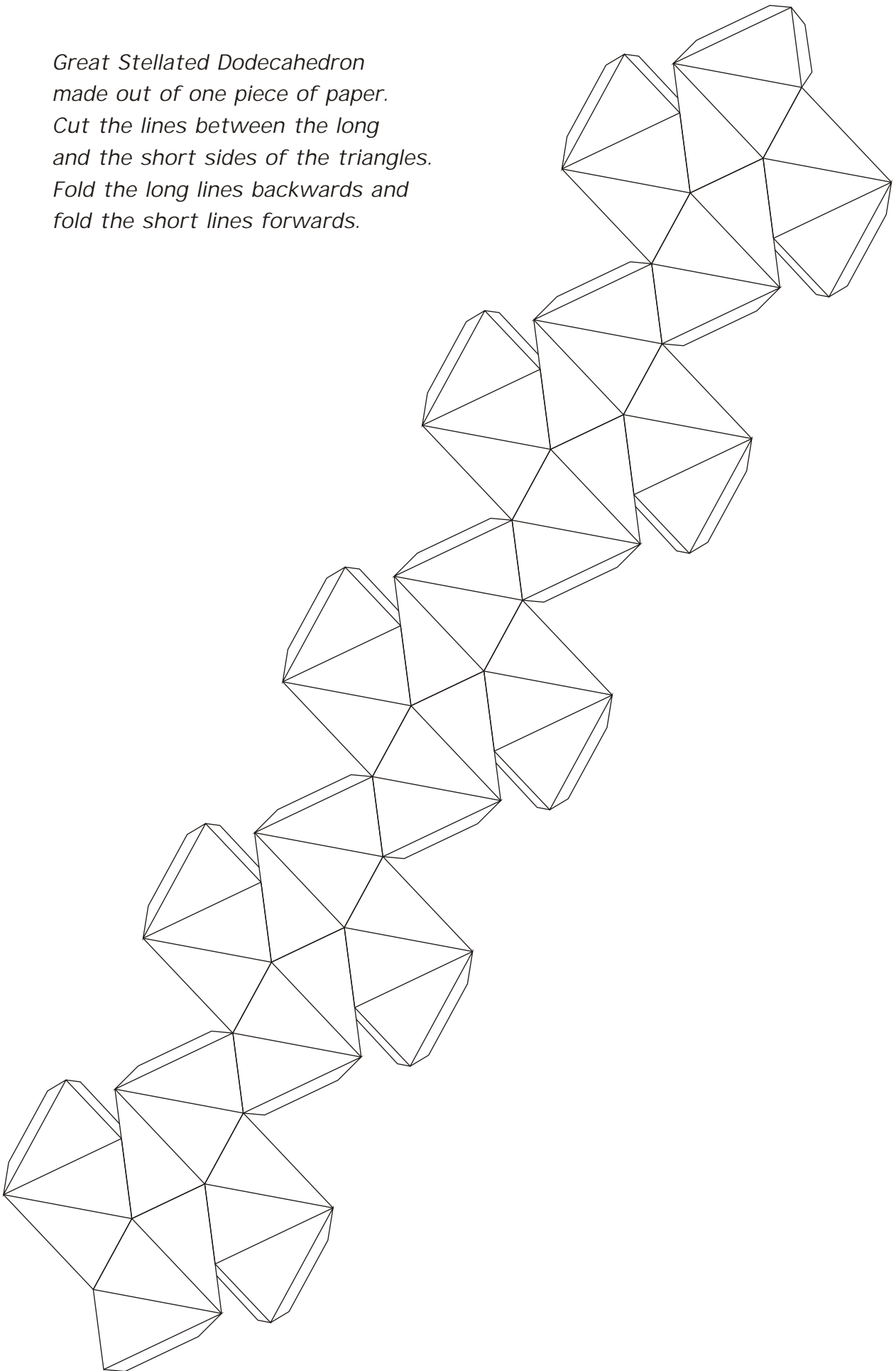

*Great Stellated Dodecahedron  
made out of two pieces of paper.  
Cut the lines between the long  
and the short sides of the triangles.  
Fold the long lines backwards and  
fold the short lines forwards.  
This is piece one. On the next page  
is piece two.*

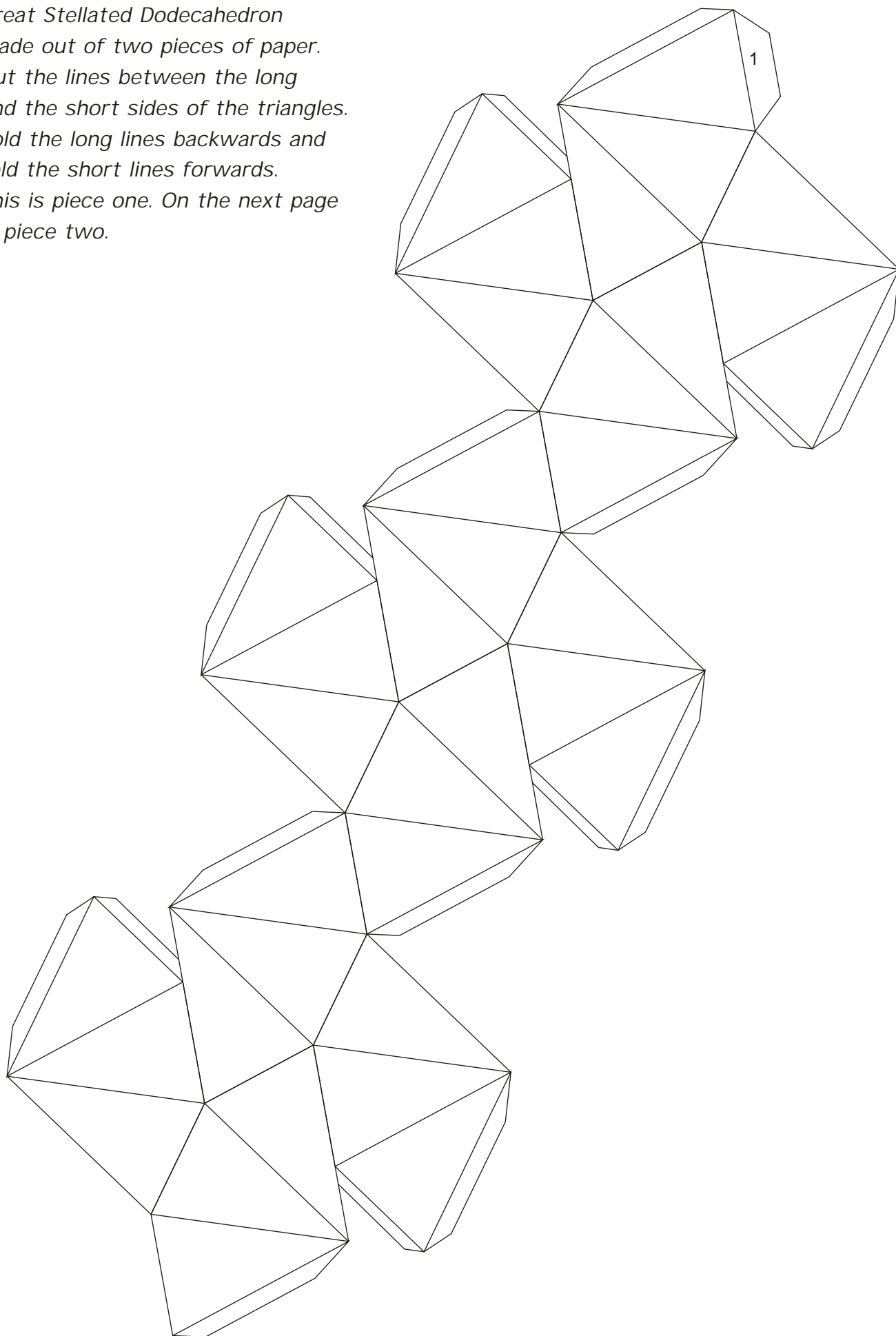

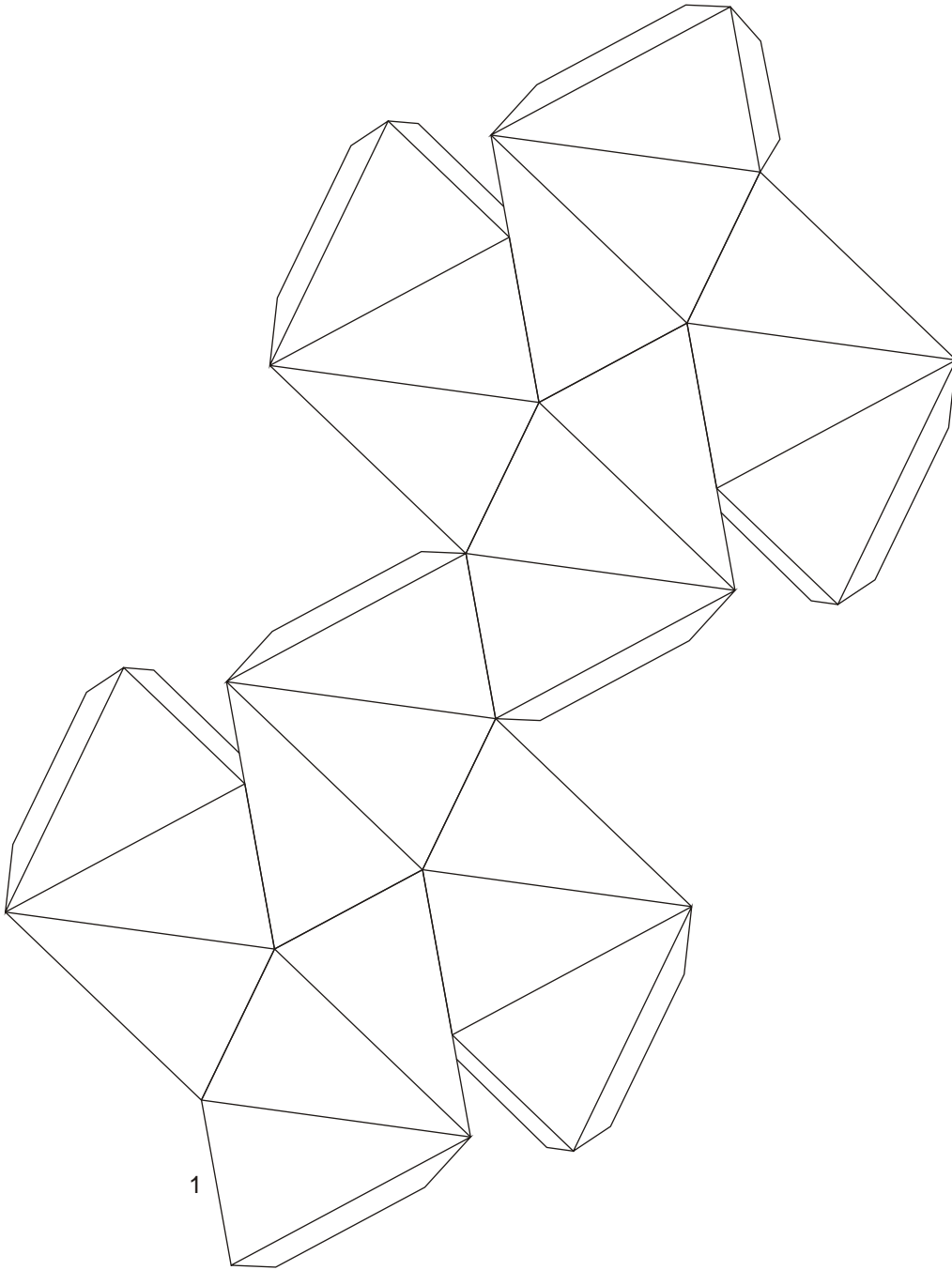

*Great Stellated Dodecahedron  
made out of five pieces of paper.  
Cut the lines between the long  
and the short sides of the triangles.  
Fold the long lines backwards and  
fold the short lines forwards.  
N= Next part P= Previous part*

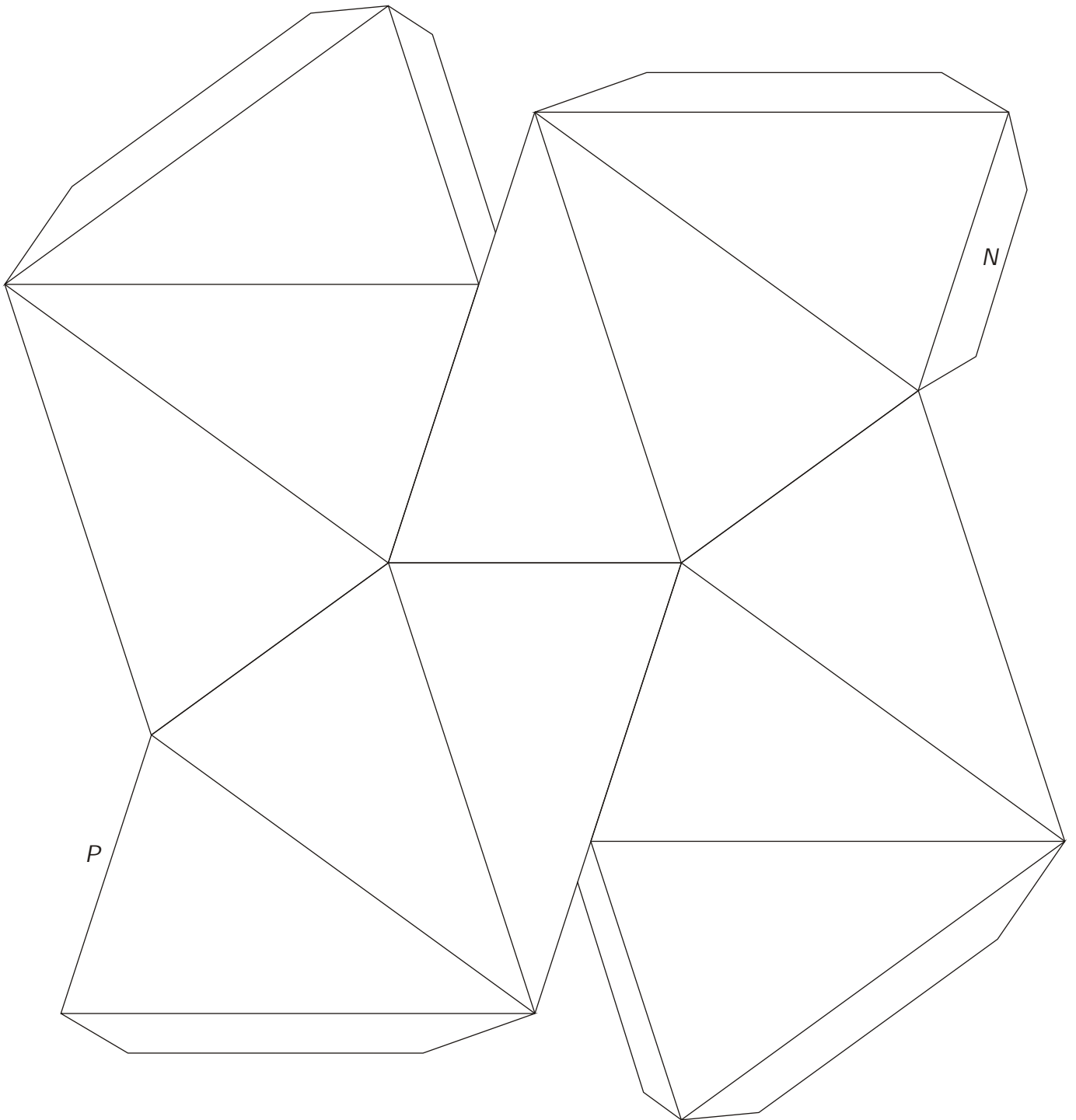

*Great Stellated Dodecahedron  
made out of five pieces of paper.  
Cut the lines between the long  
and the short sides of the triangles.  
Fold the long lines backwards and  
fold the short lines forwards.  
N= Next part P= Previous part*

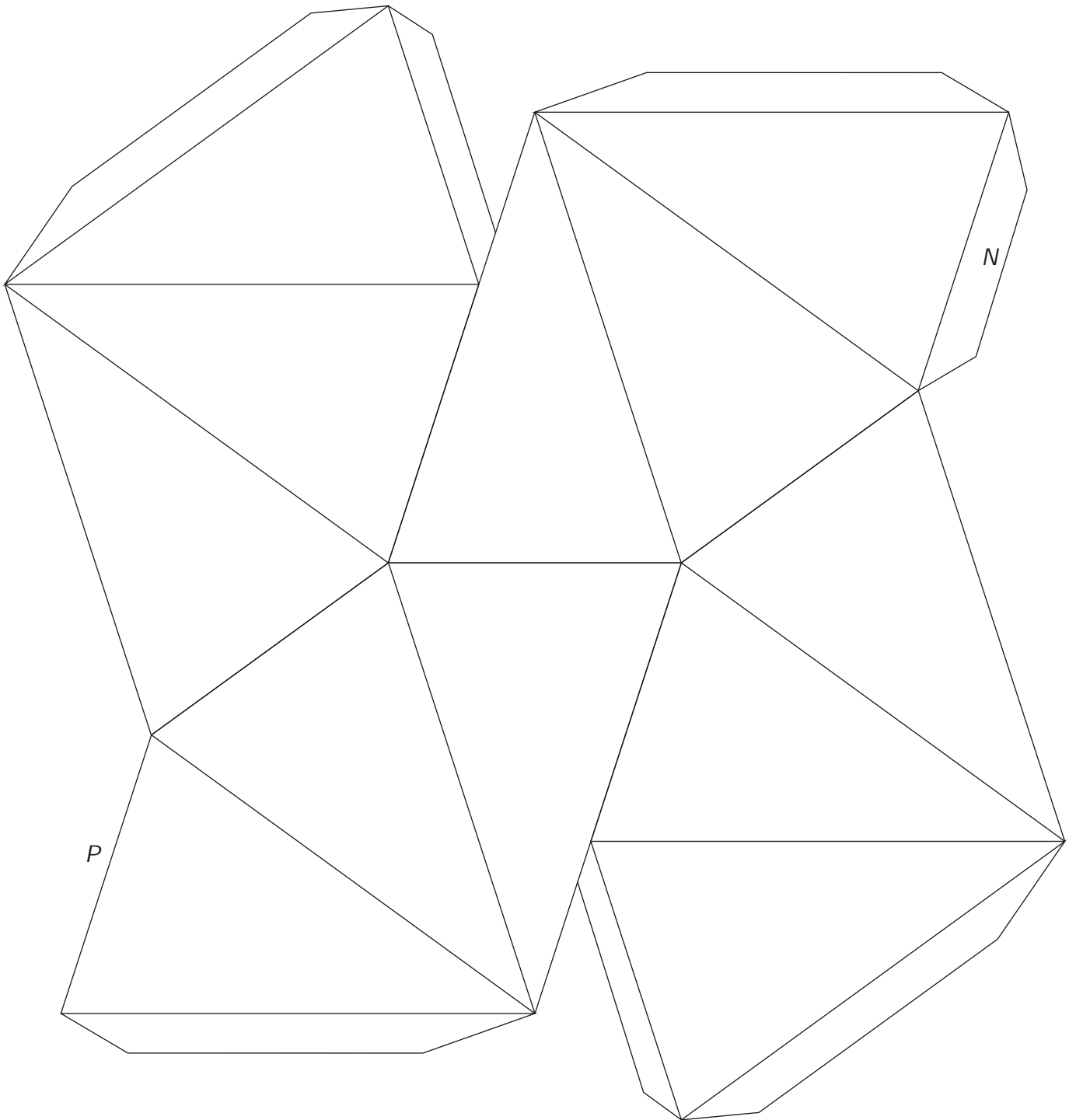

*Great Stellated Dodecahedron  
made out of five pieces of paper.  
Cut the lines between the long  
and the short sides of the triangles.  
Fold the long lines backwards and  
fold the short lines forwards.  
N= Next part P= Previous part*

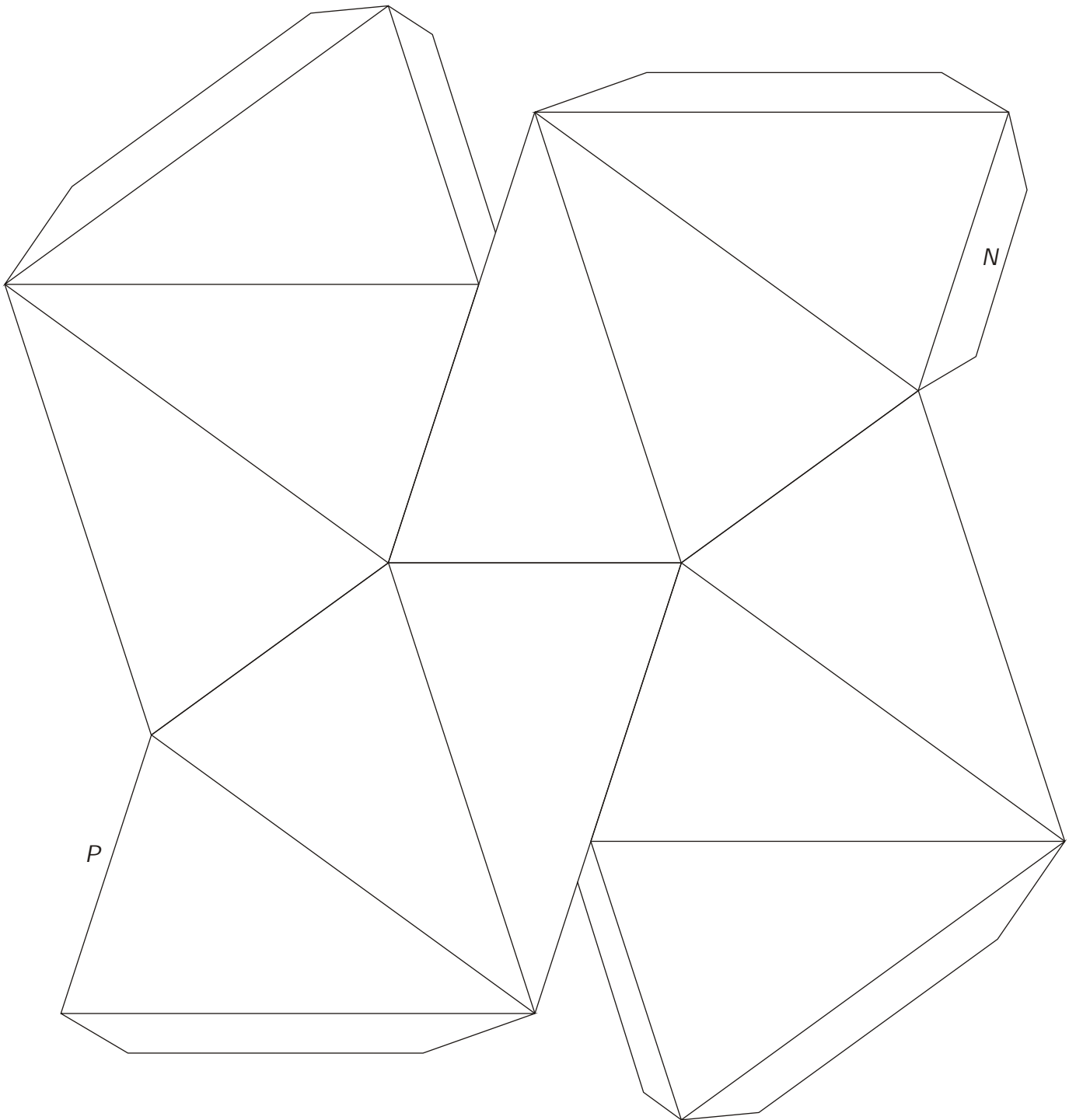

*Great Stellated Dodecahedron  
made out of five pieces of paper.  
Cut the lines between the long  
and the short sides of the triangles.  
Fold the long lines backwards and  
fold the short lines forwards.  
N= Next part P= Previous part*

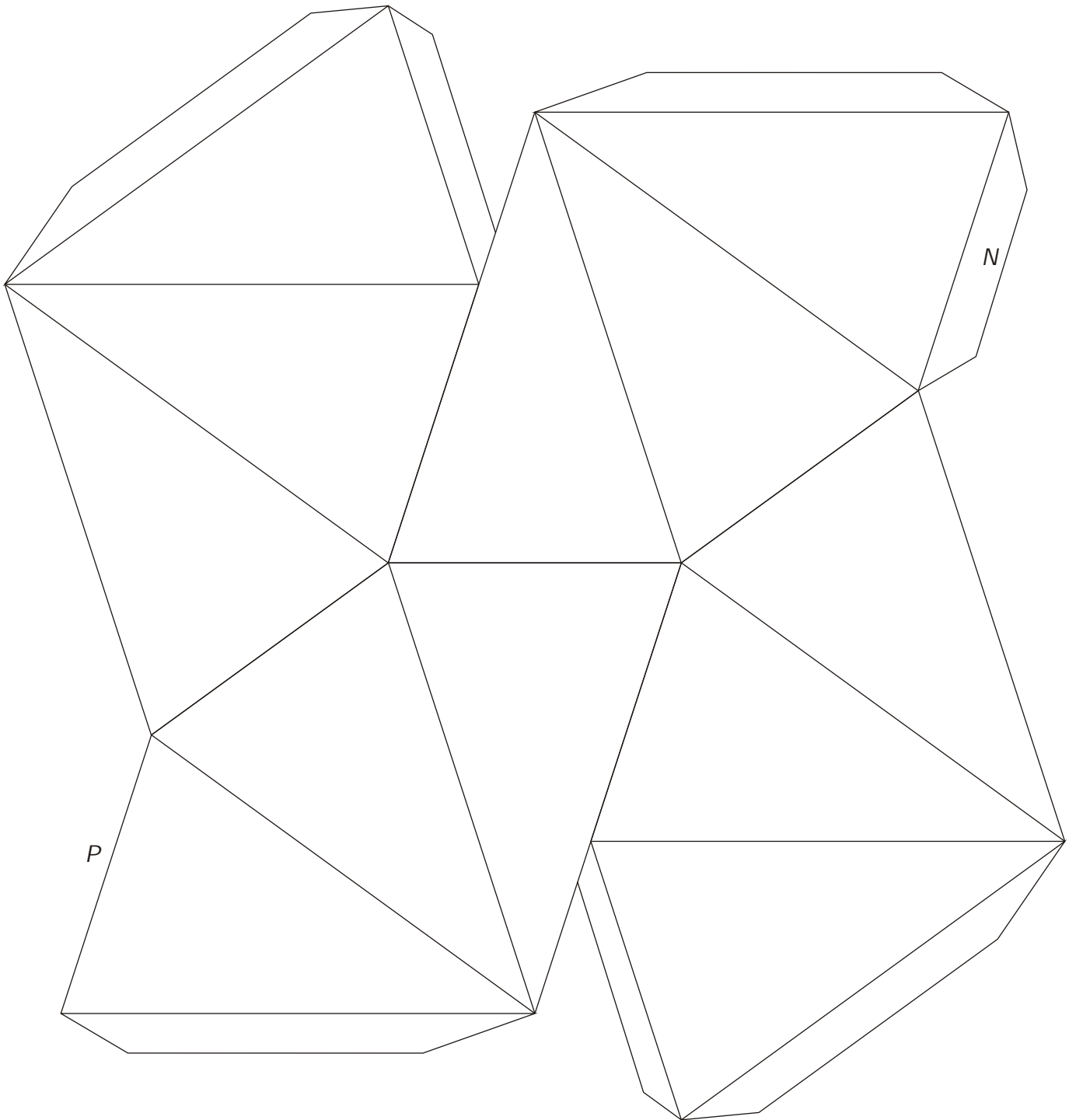

*Great Stellated Dodecahedron  
made out of five pieces of paper.  
Cut the lines between the long  
and the short sides of the triangles.  
Fold the long lines backwards and  
fold the short lines forwards.  
N= Next part P= Previous part*

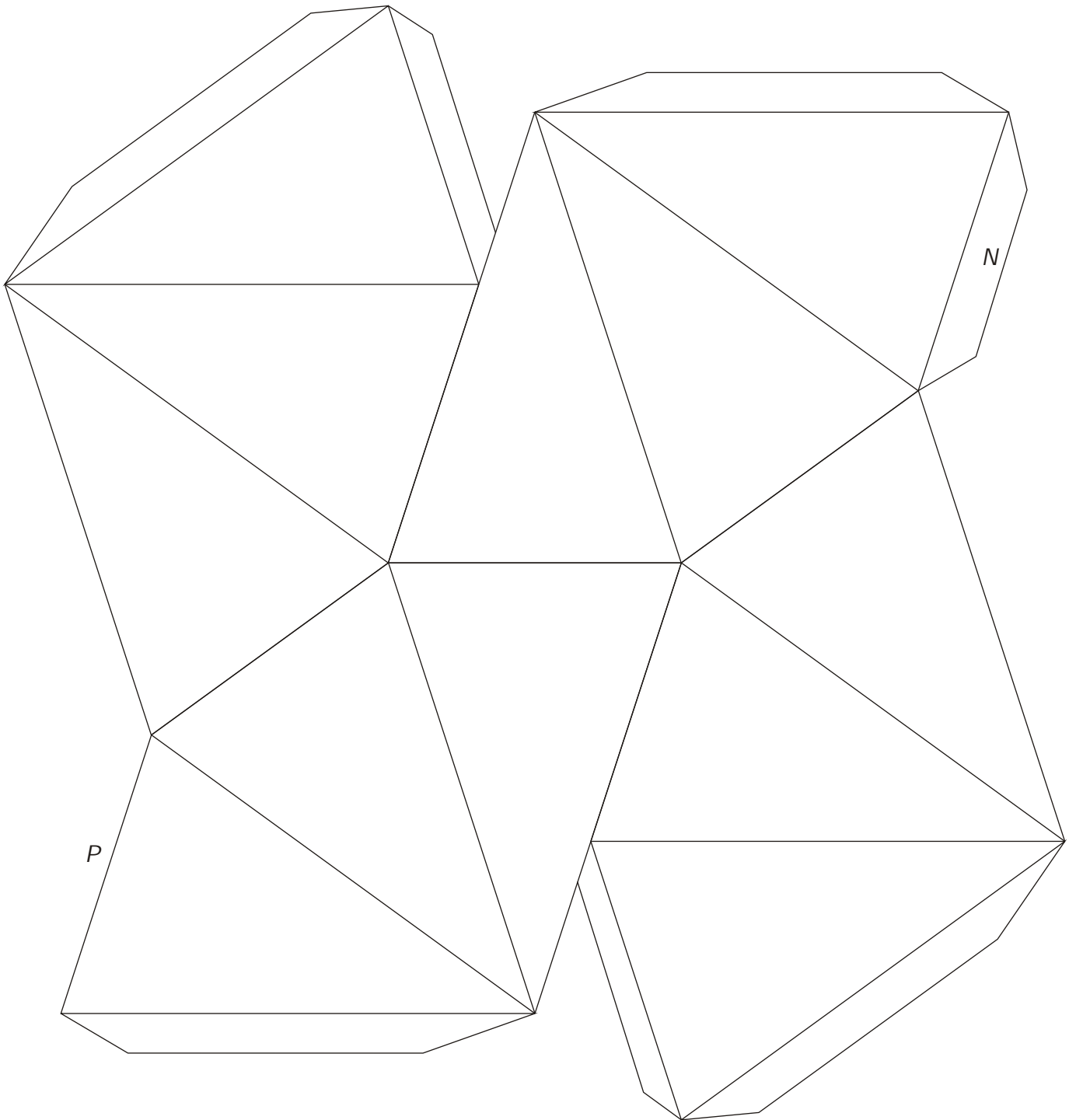



Pentagonale hexacontahedron

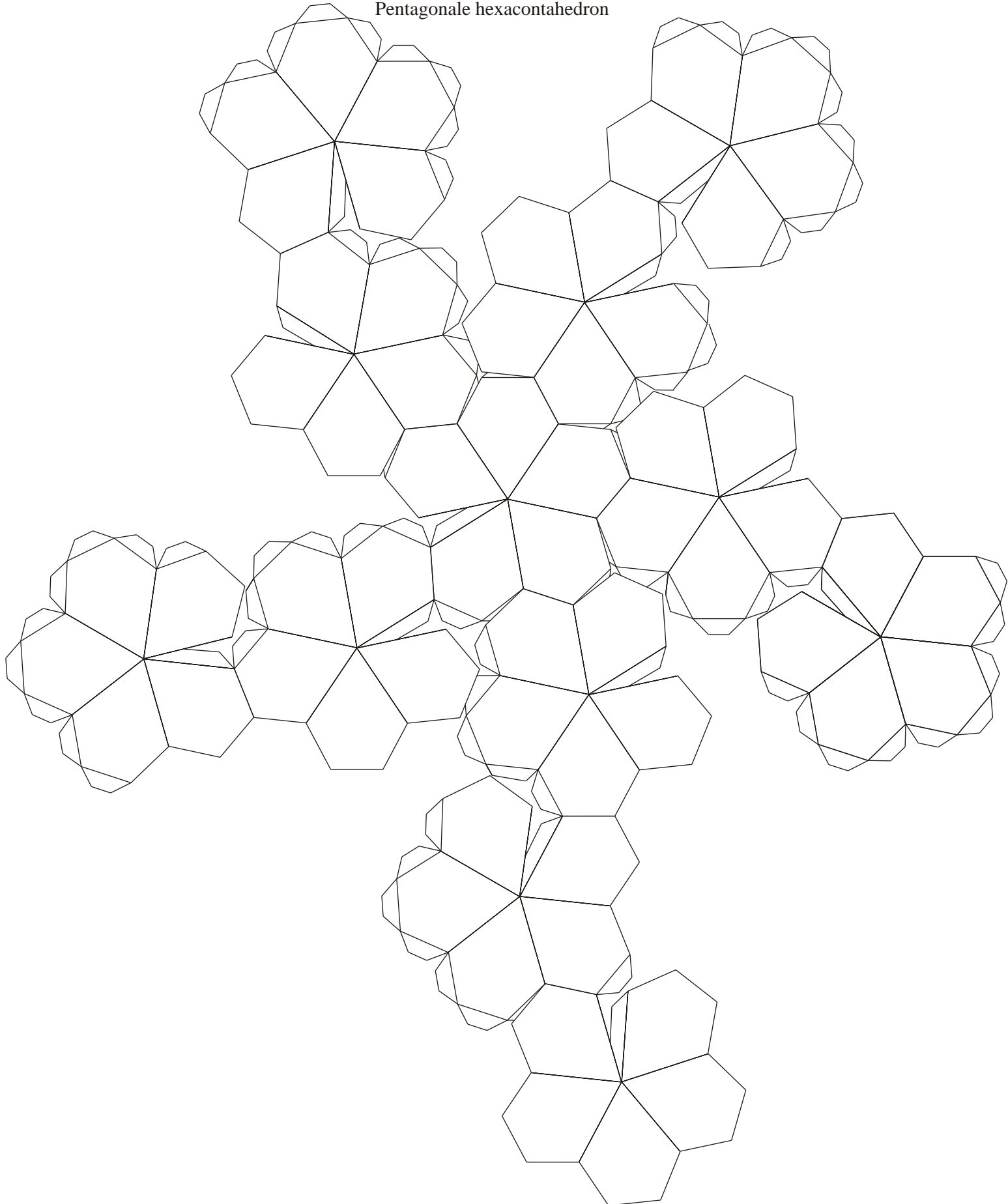

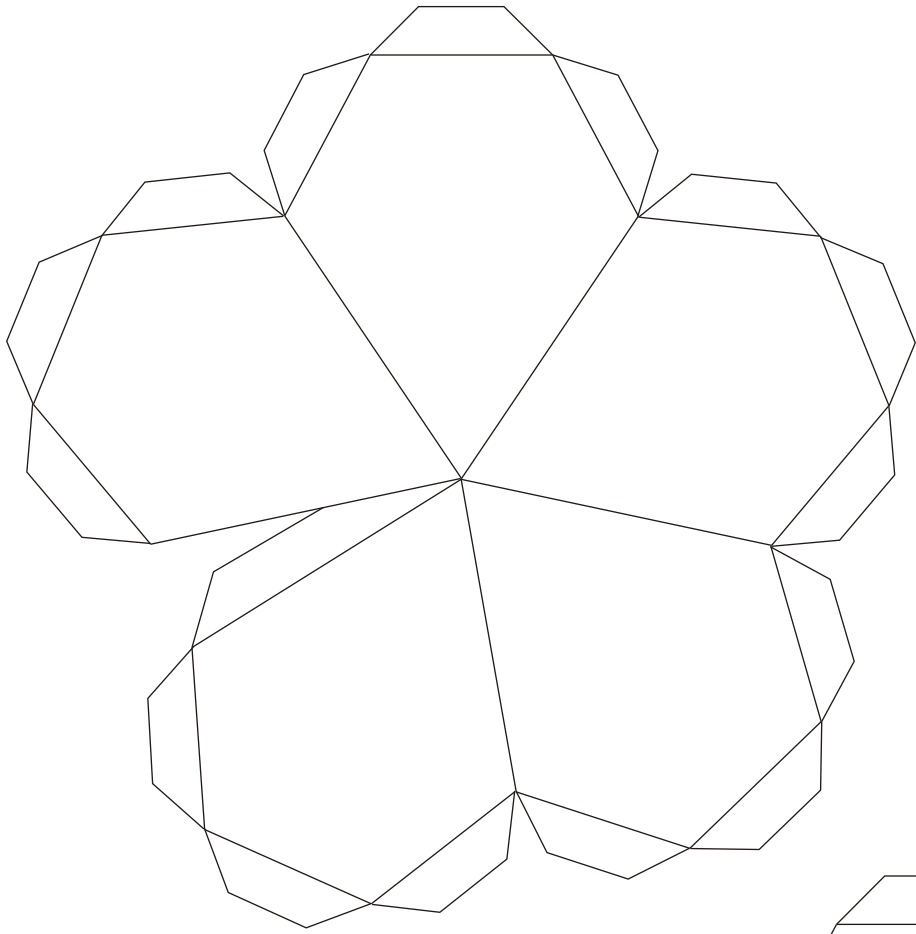

1

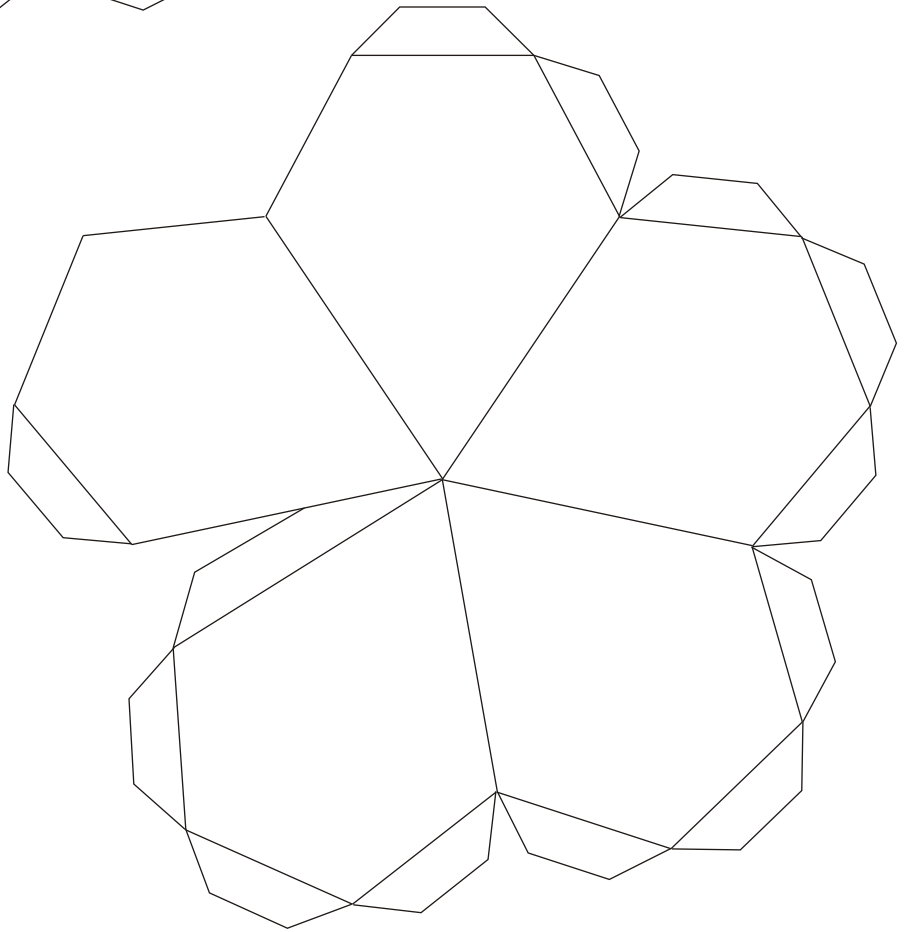

2

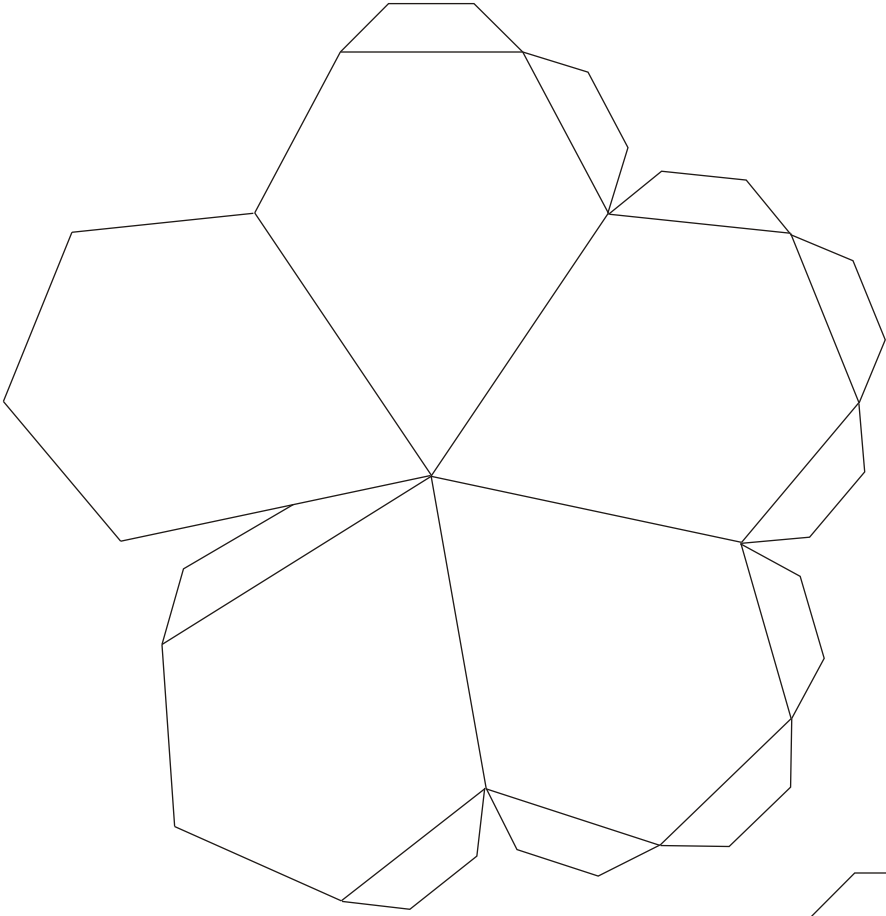

3

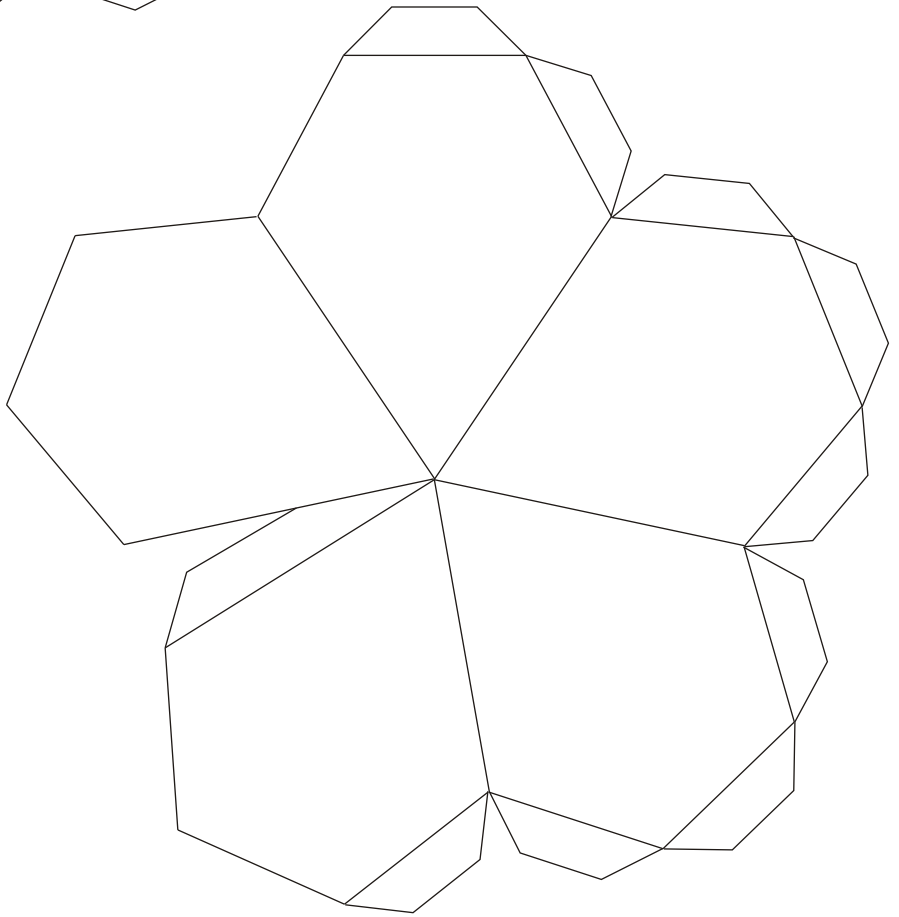

4

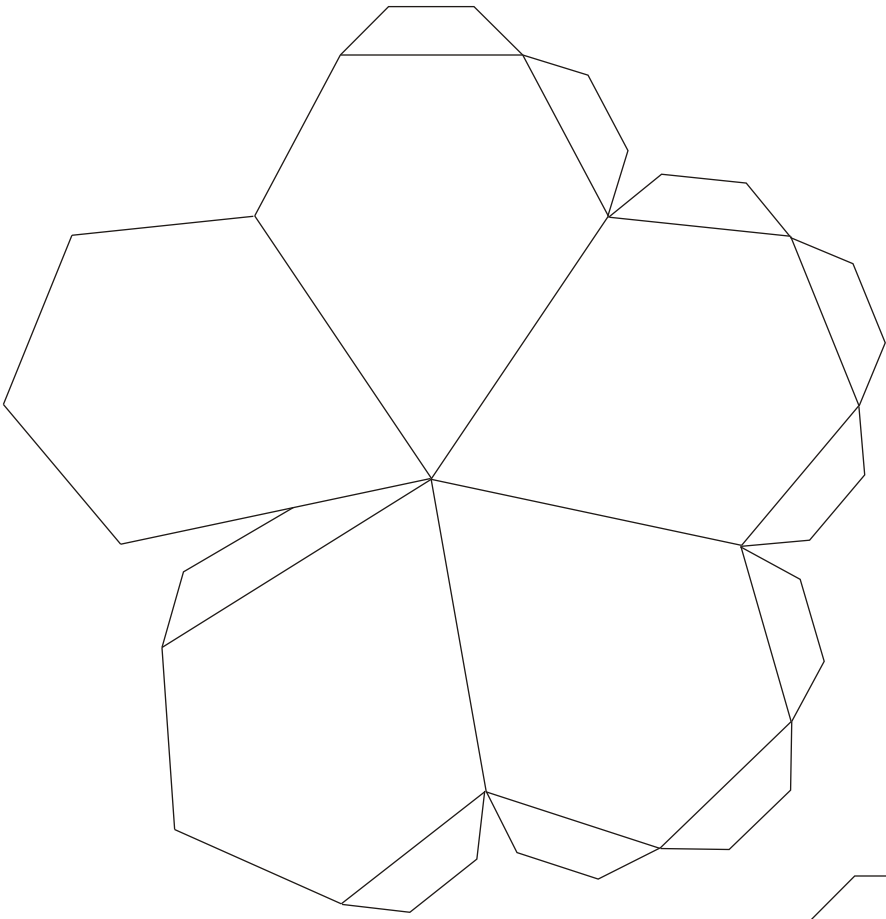

5

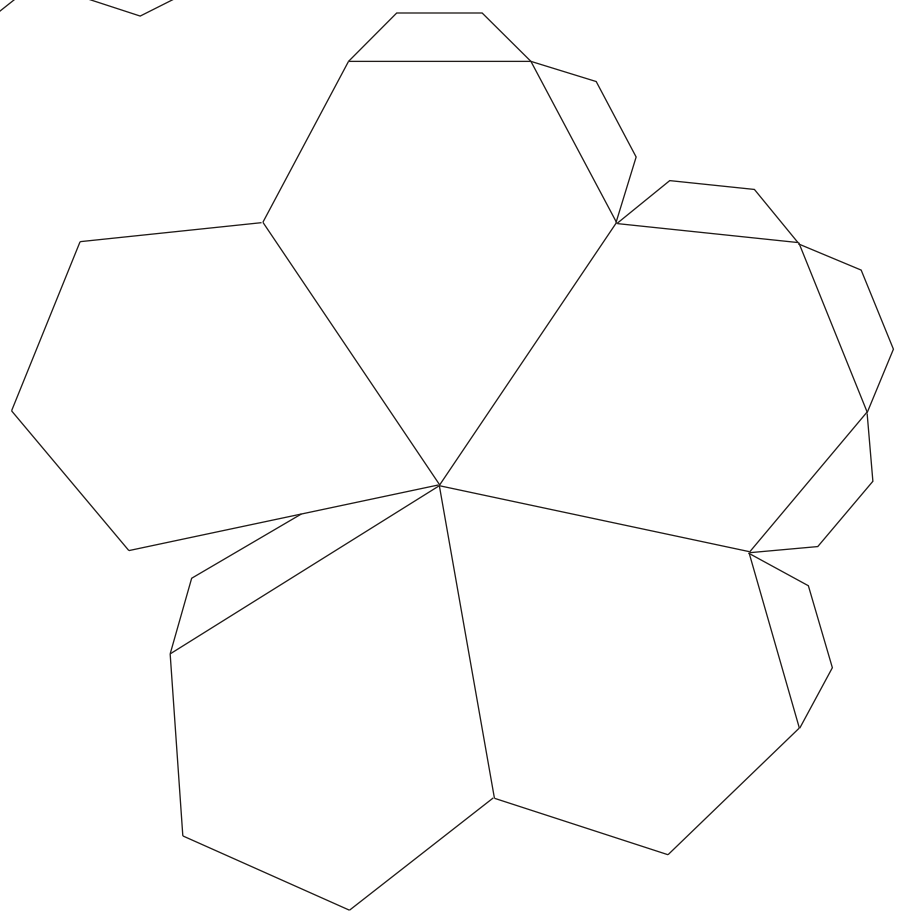

6

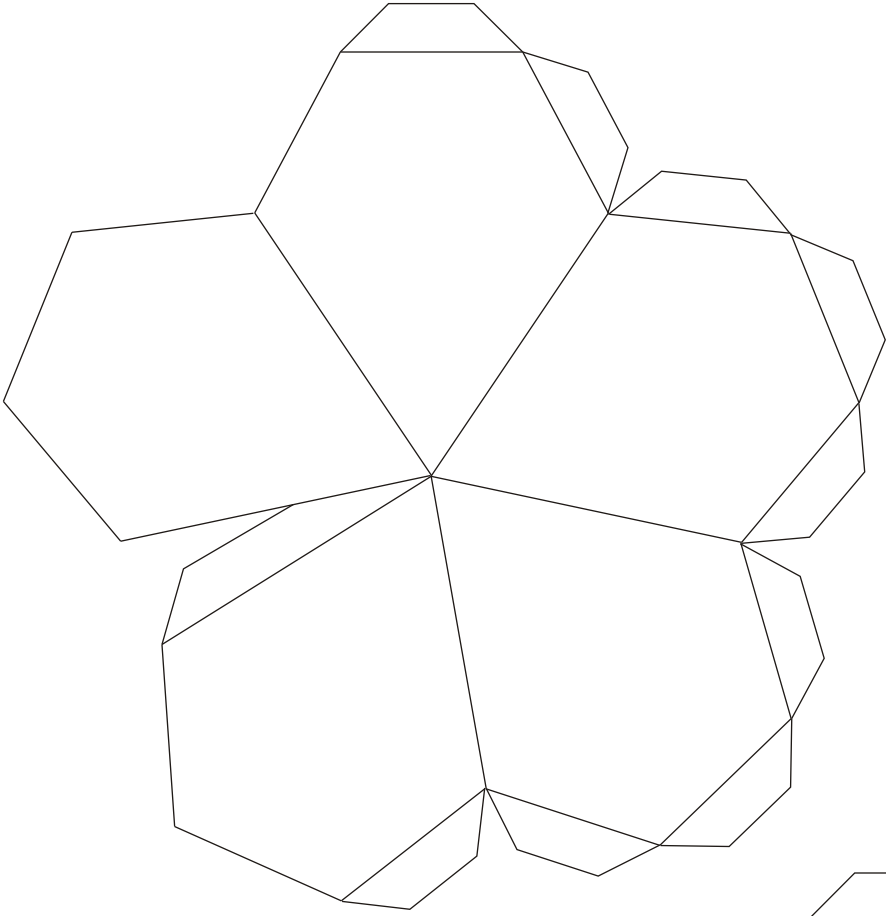

7

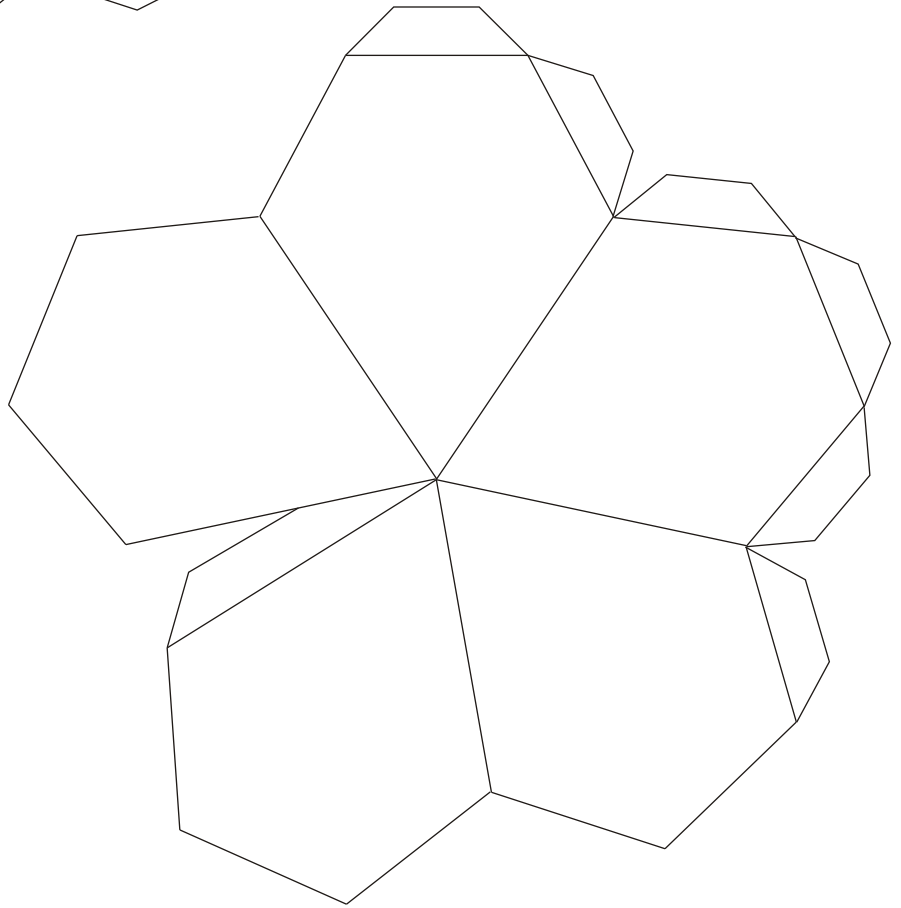

8

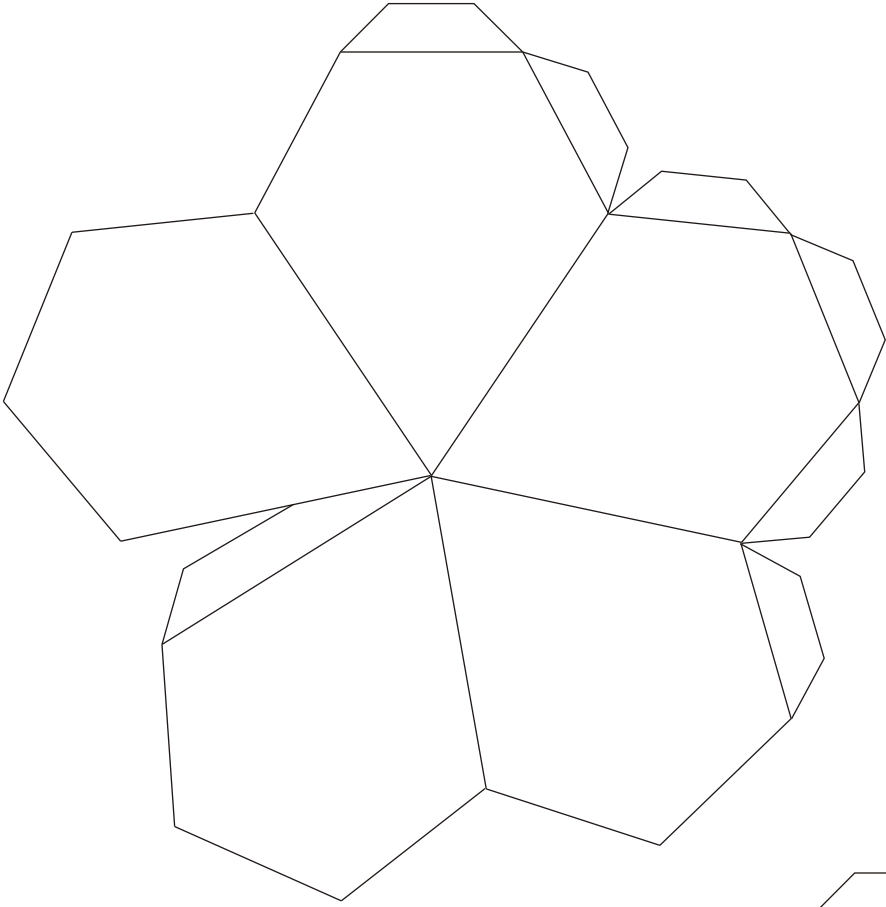

9

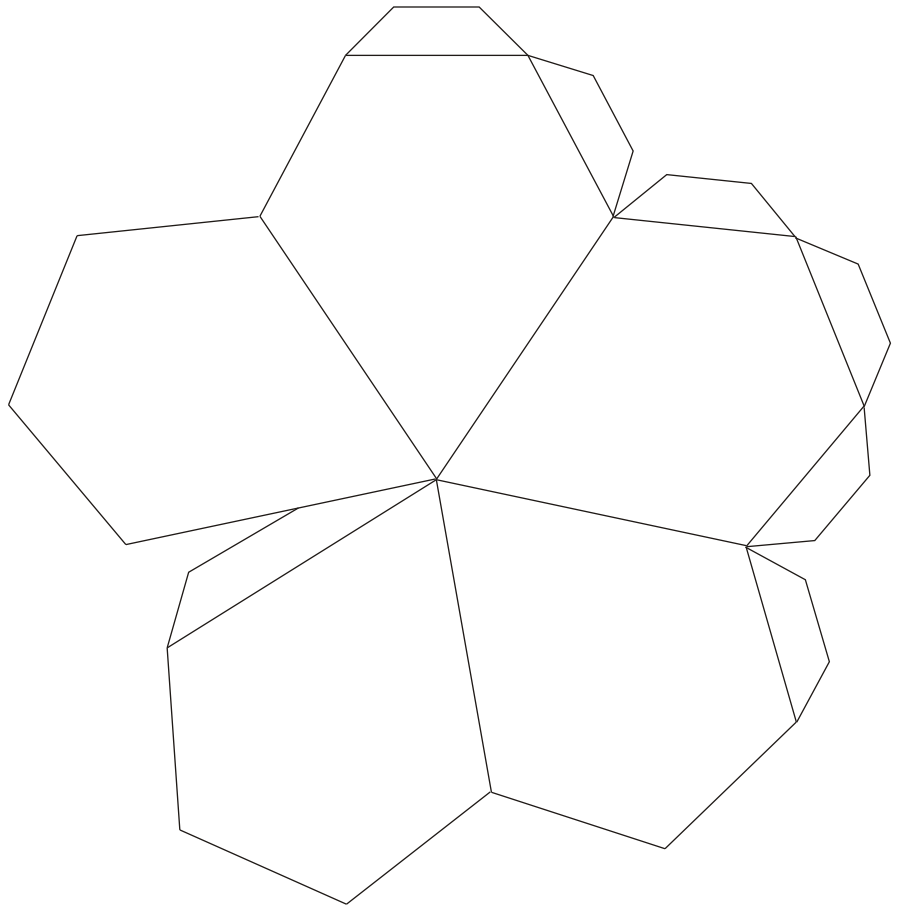

10

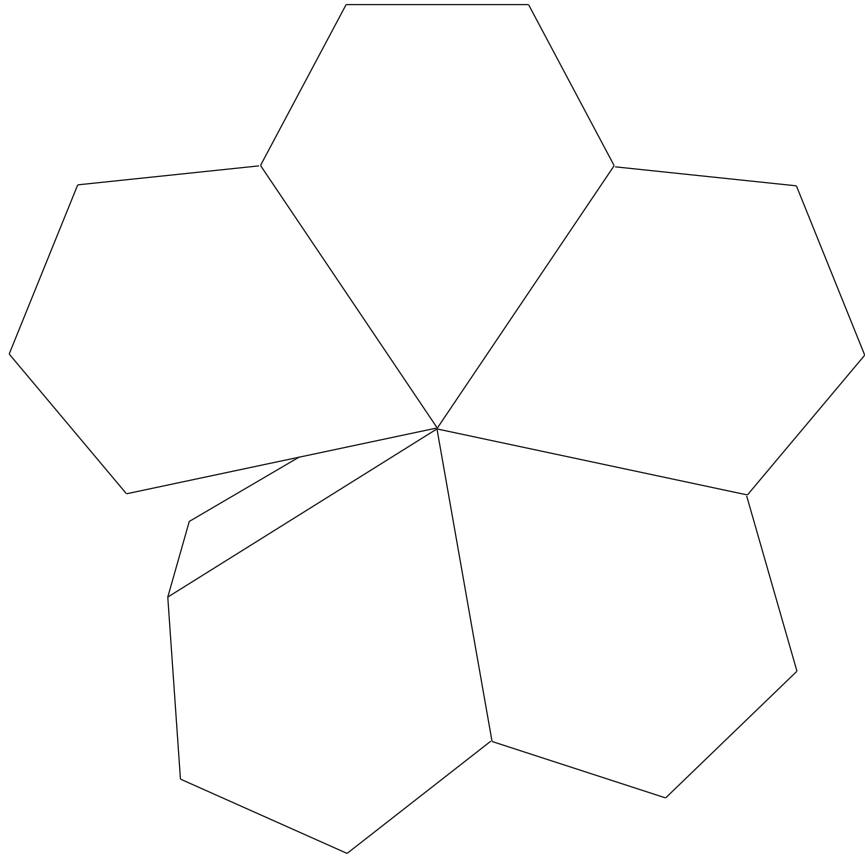
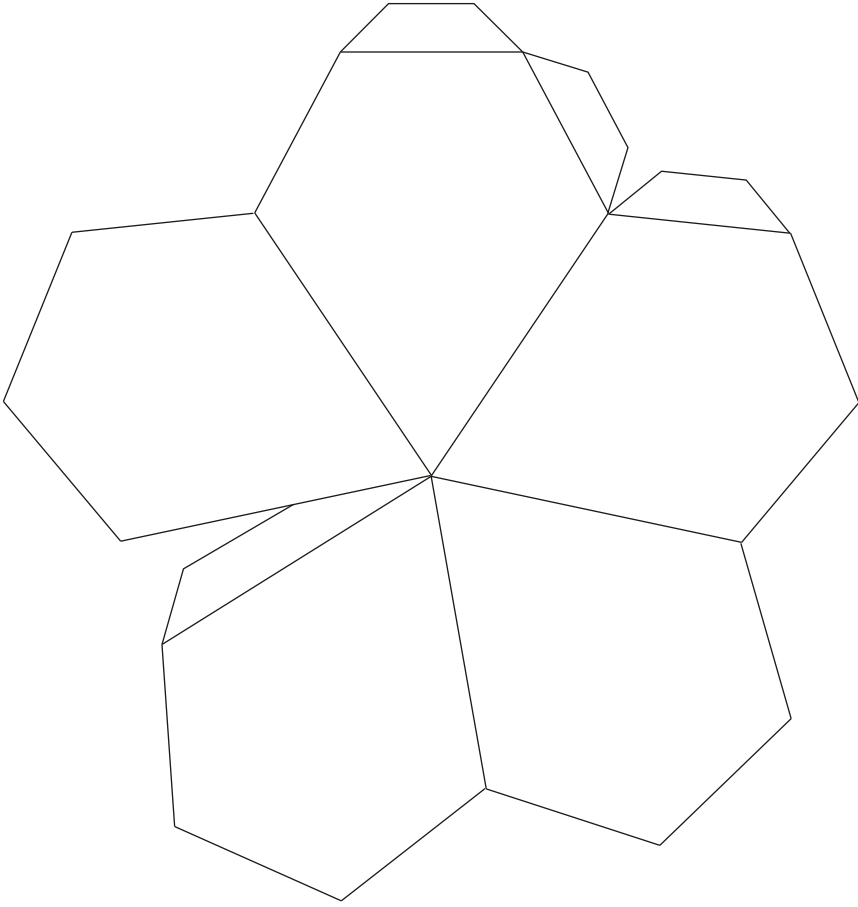

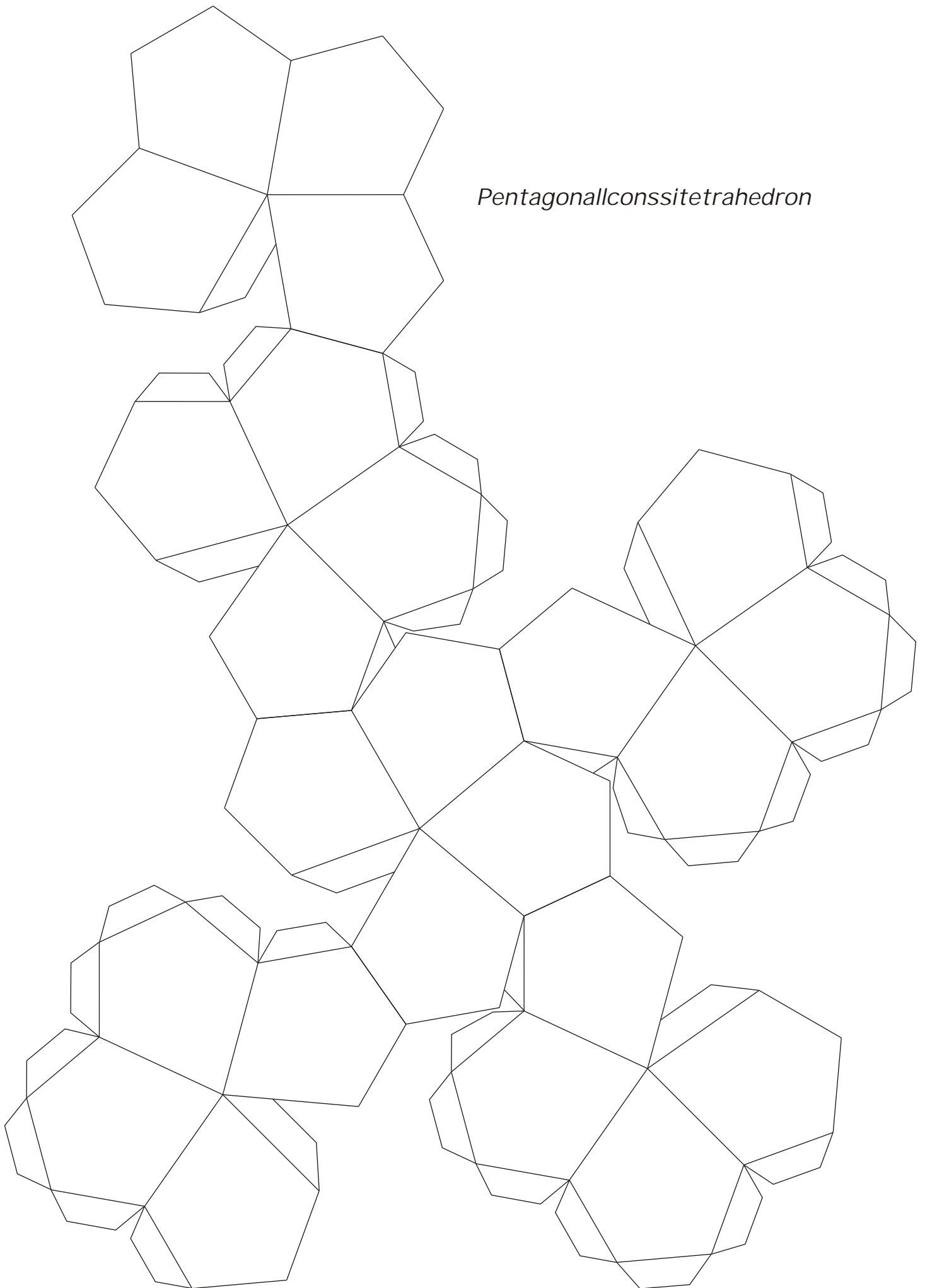

*Pentagonallconssitetrahedron*



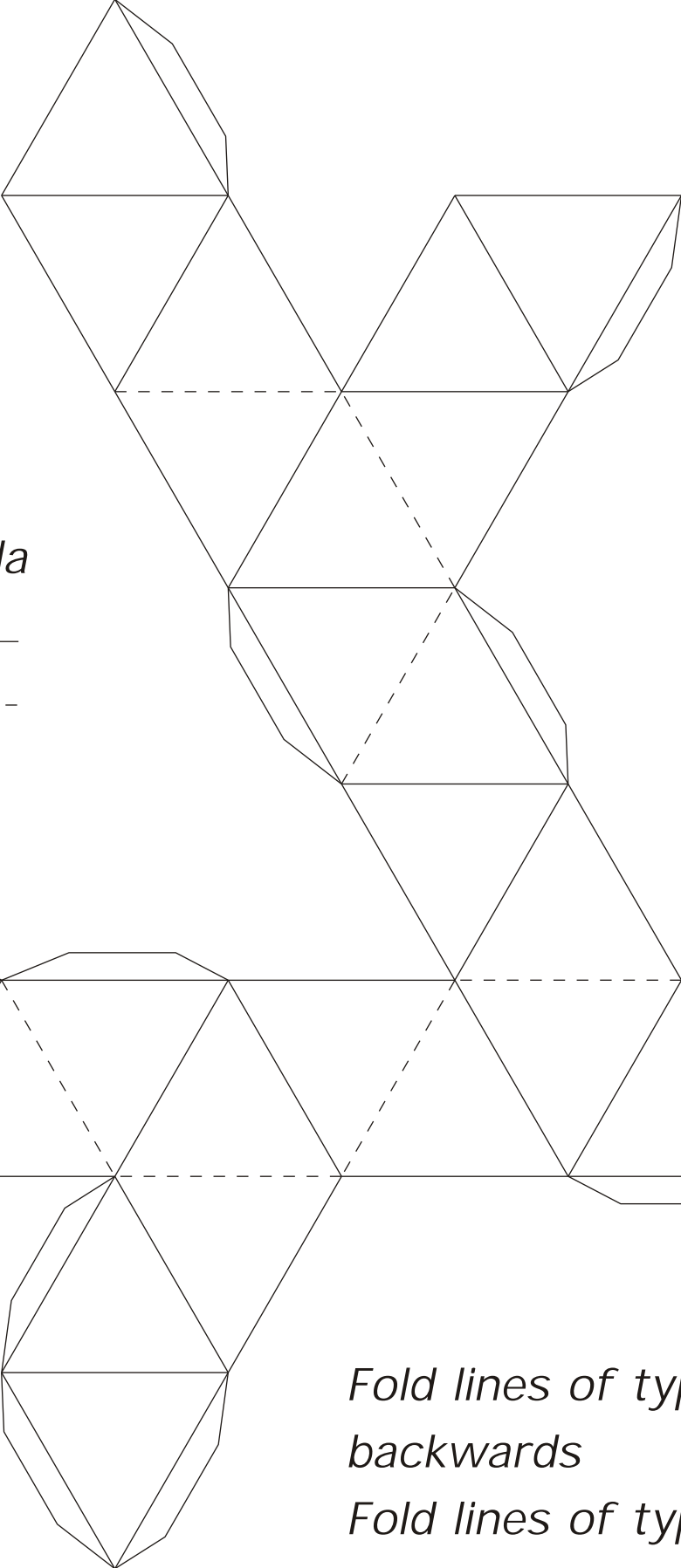

*Stella Octangula*

Type 1 ———

Type 2 - - - - -

*Fold lines of type 1  
backwards*

*Fold lines of type 2  
forwards*

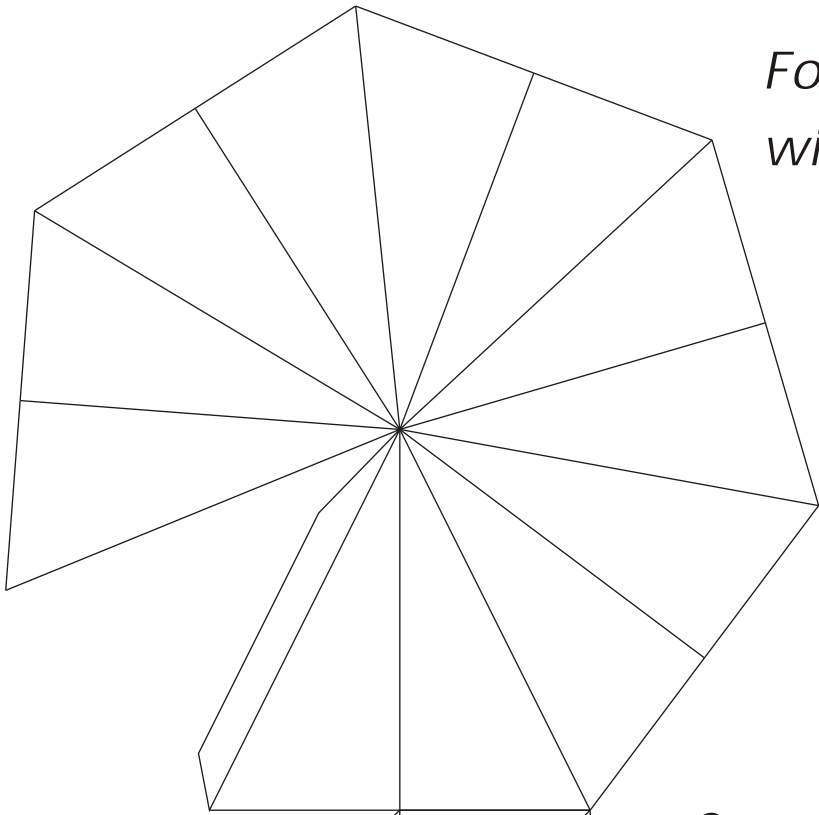

*Fold the lines  
with a rightangle  
backwards  
fold the other  
lines forwards*

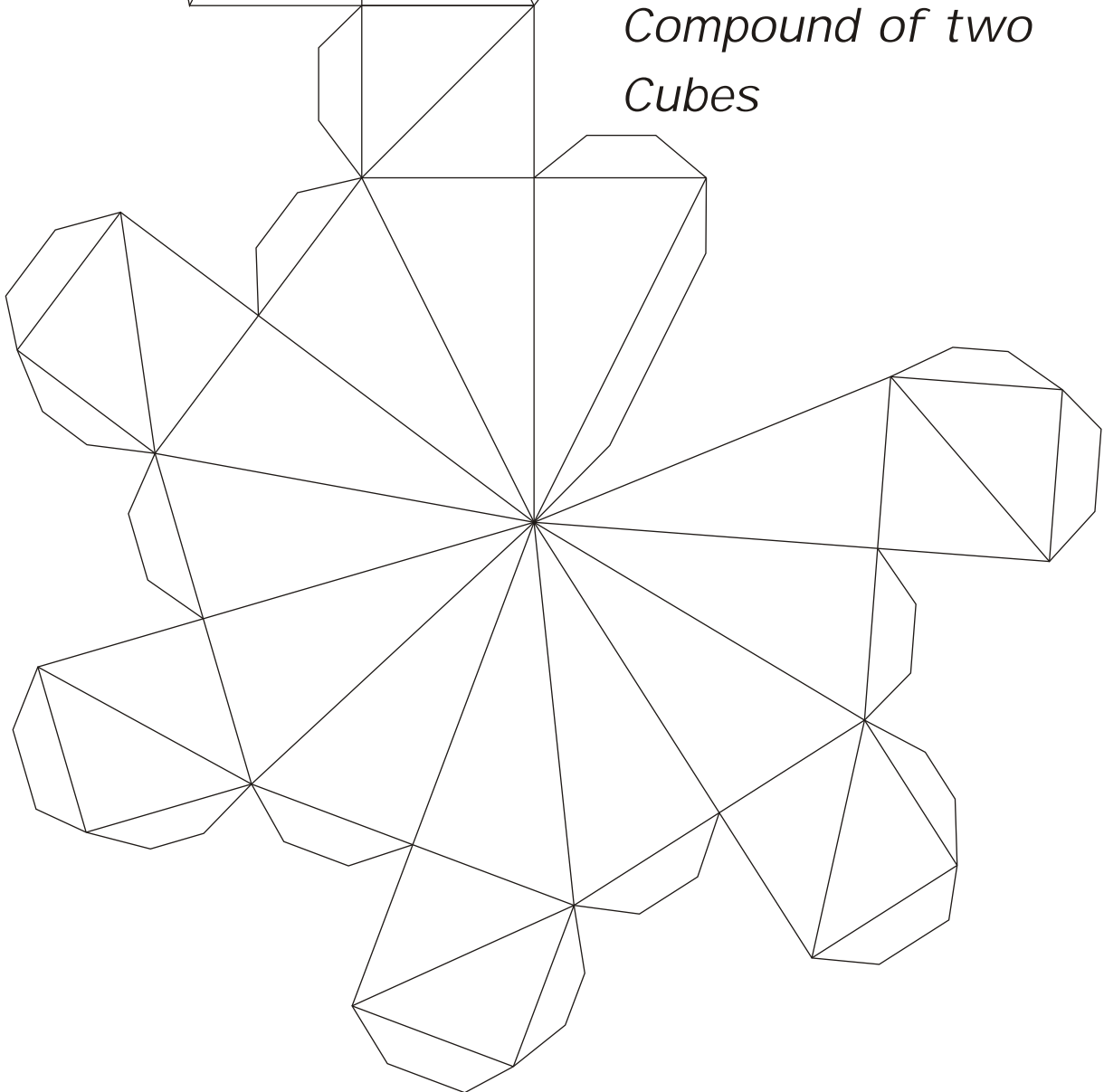

*Compound of two  
Cubes*

## Compound of Three Cubes

(Small version)

Fold the dotted lines forwards

Fold the other lines backwards

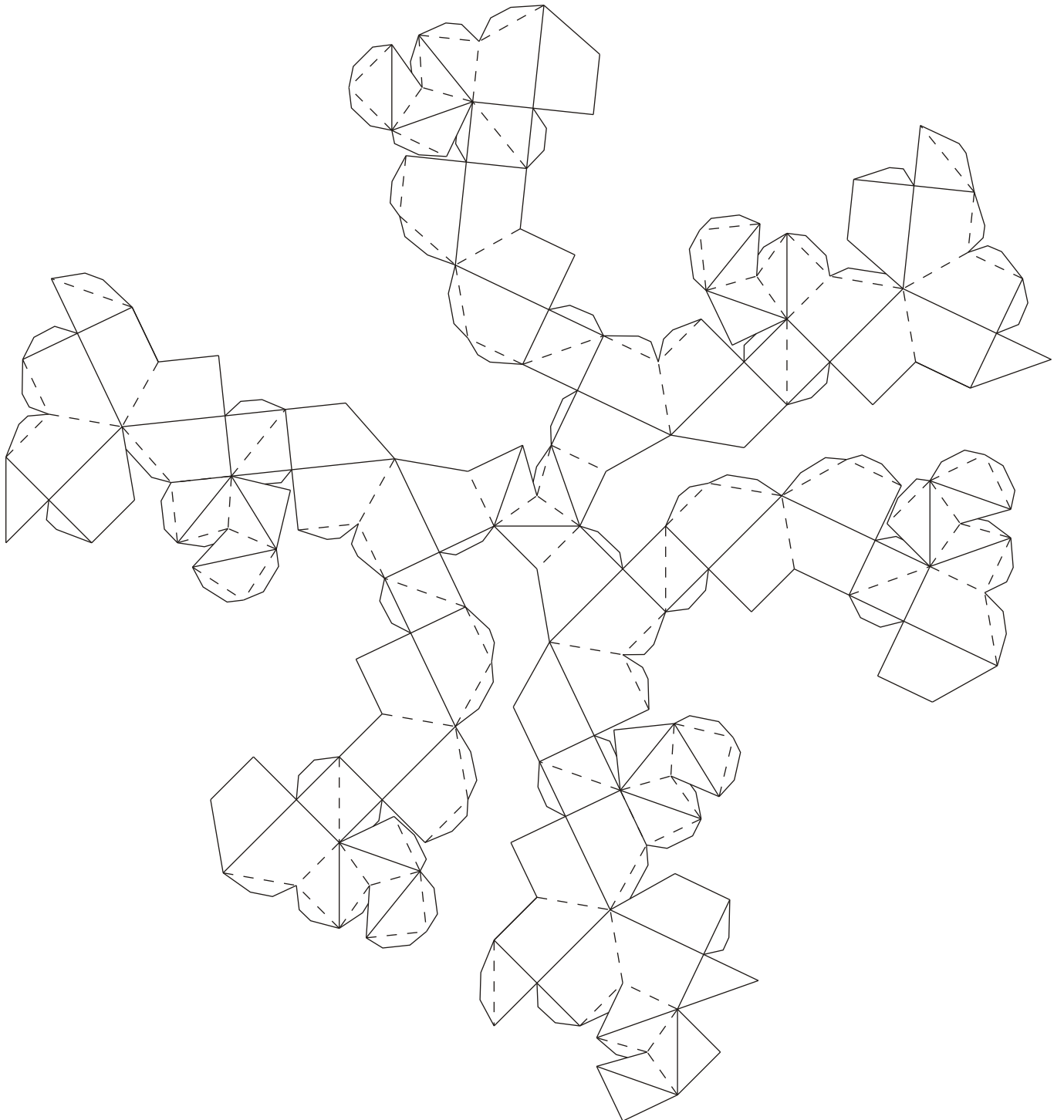

# Compound of Three Cubes

(Small version)

Fold the dotted lines forwards

Fold the other lines backwards

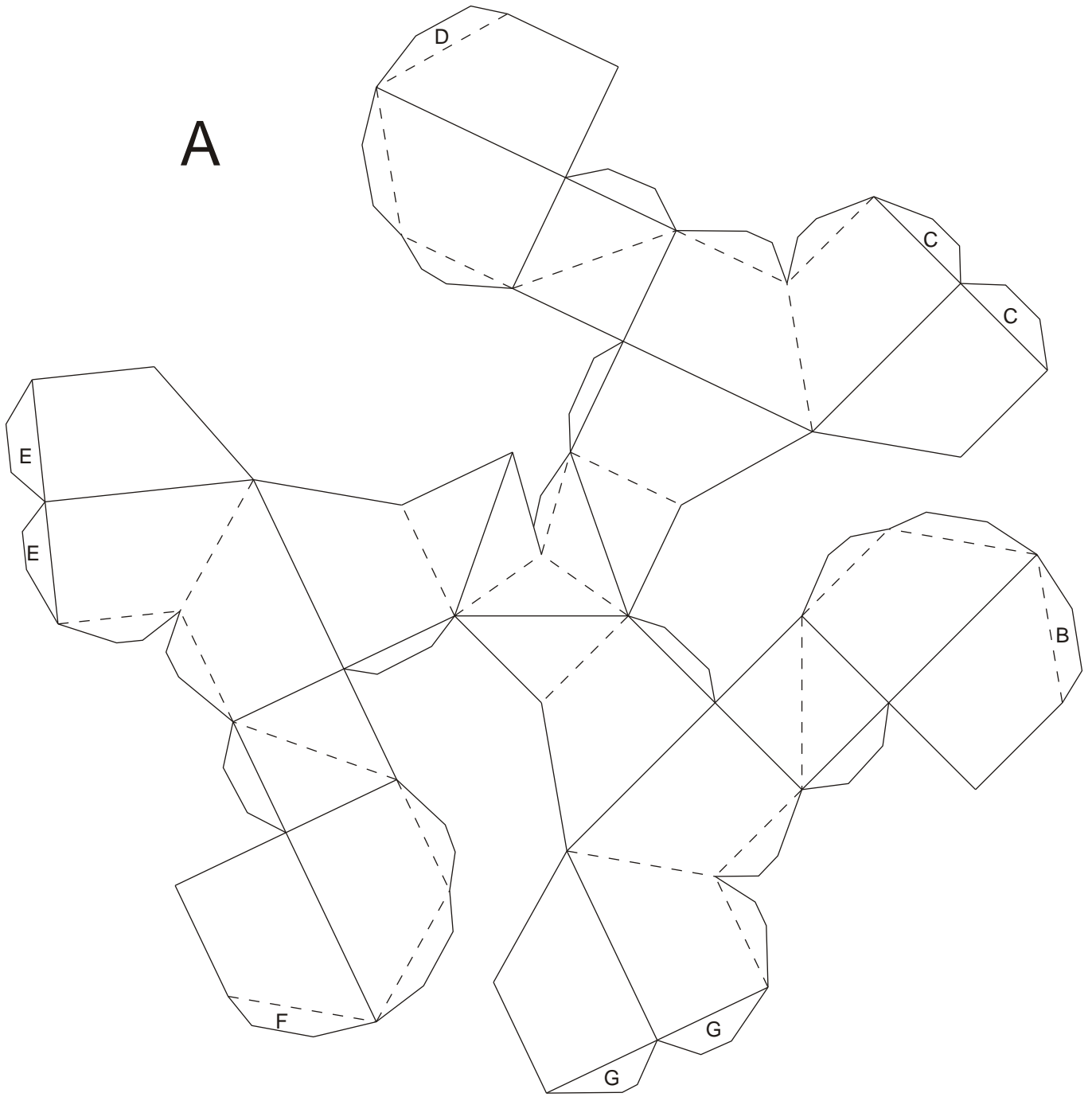

**B**

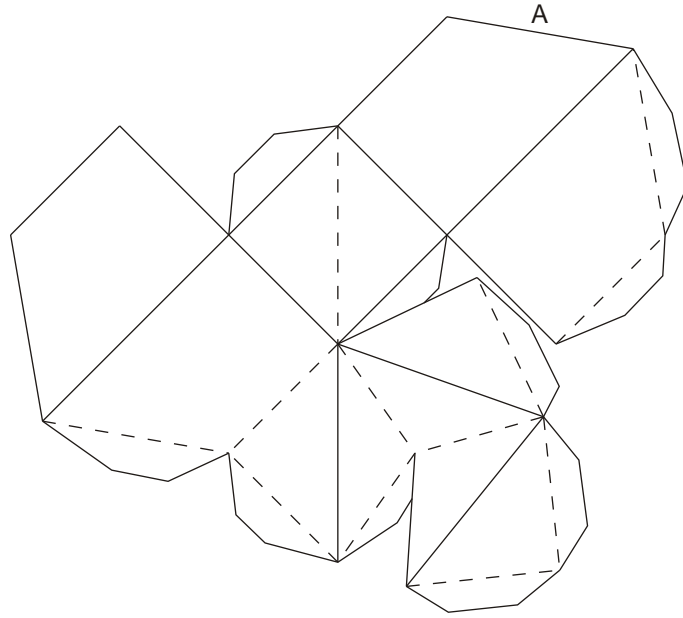

**C**

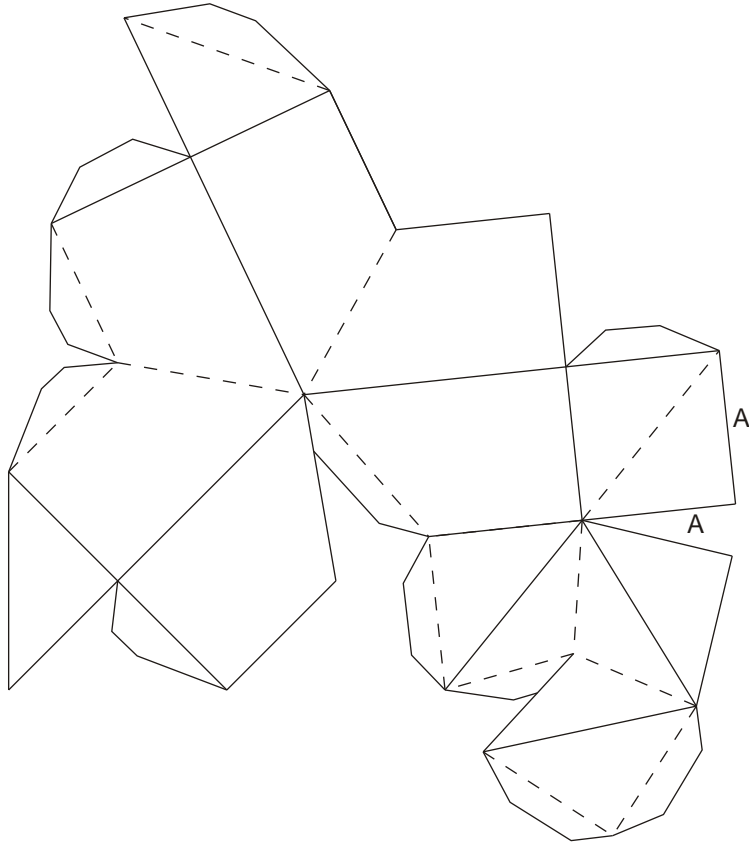

D

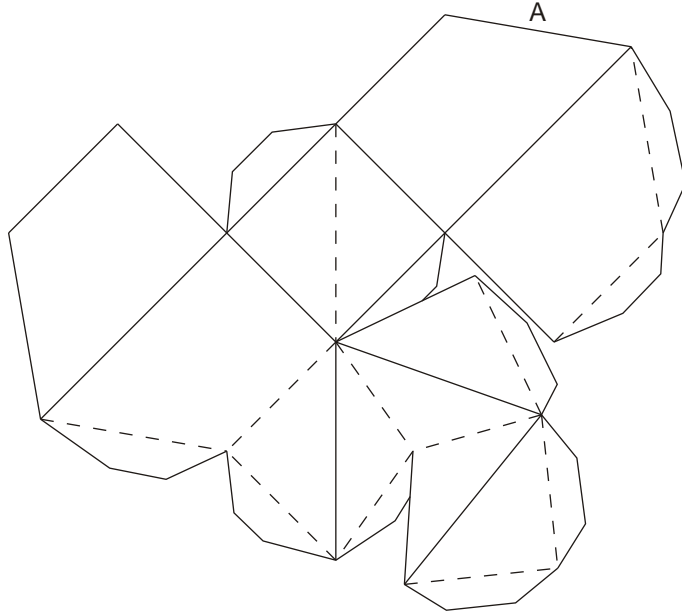

E

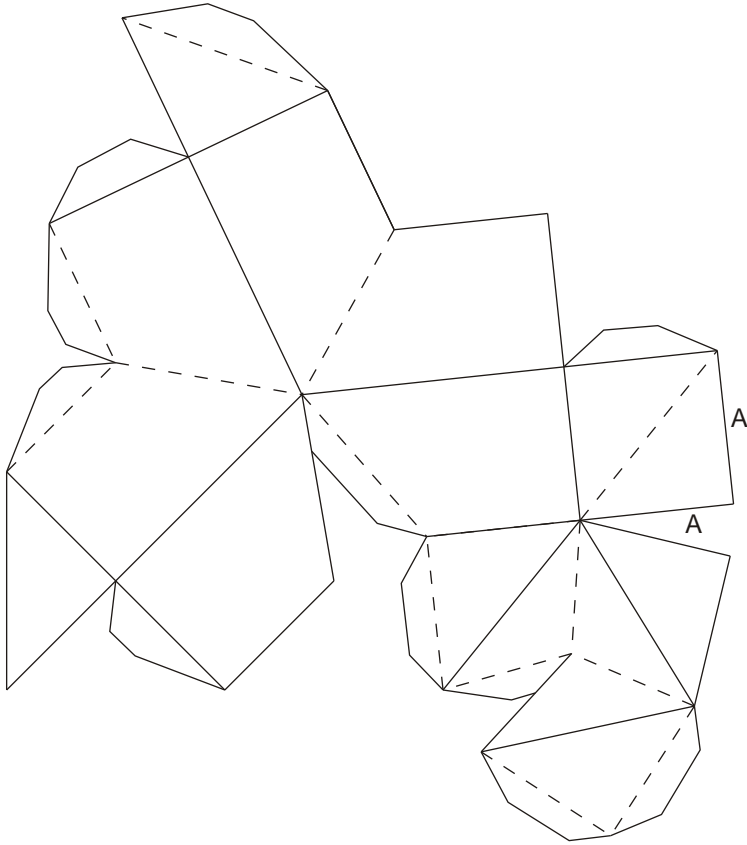

**F**

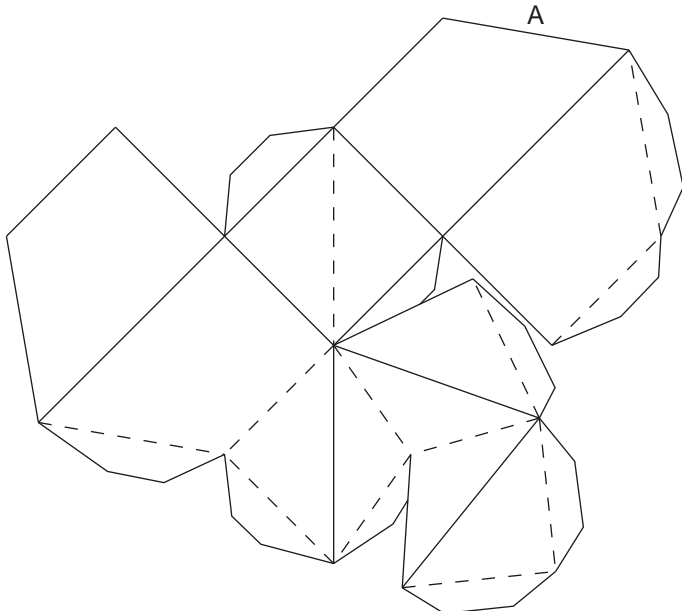

**G**

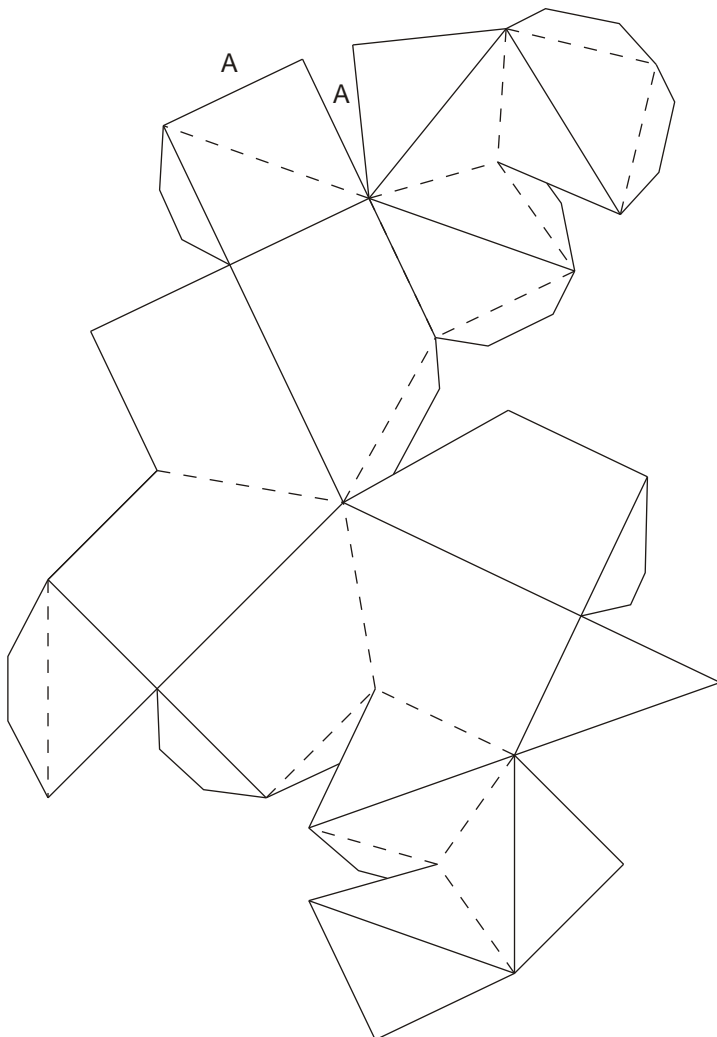

On this page a compound of five cubes  
made of one piece of paper.

On the next pages a compound of five  
cubes made of 7 pieces of paper

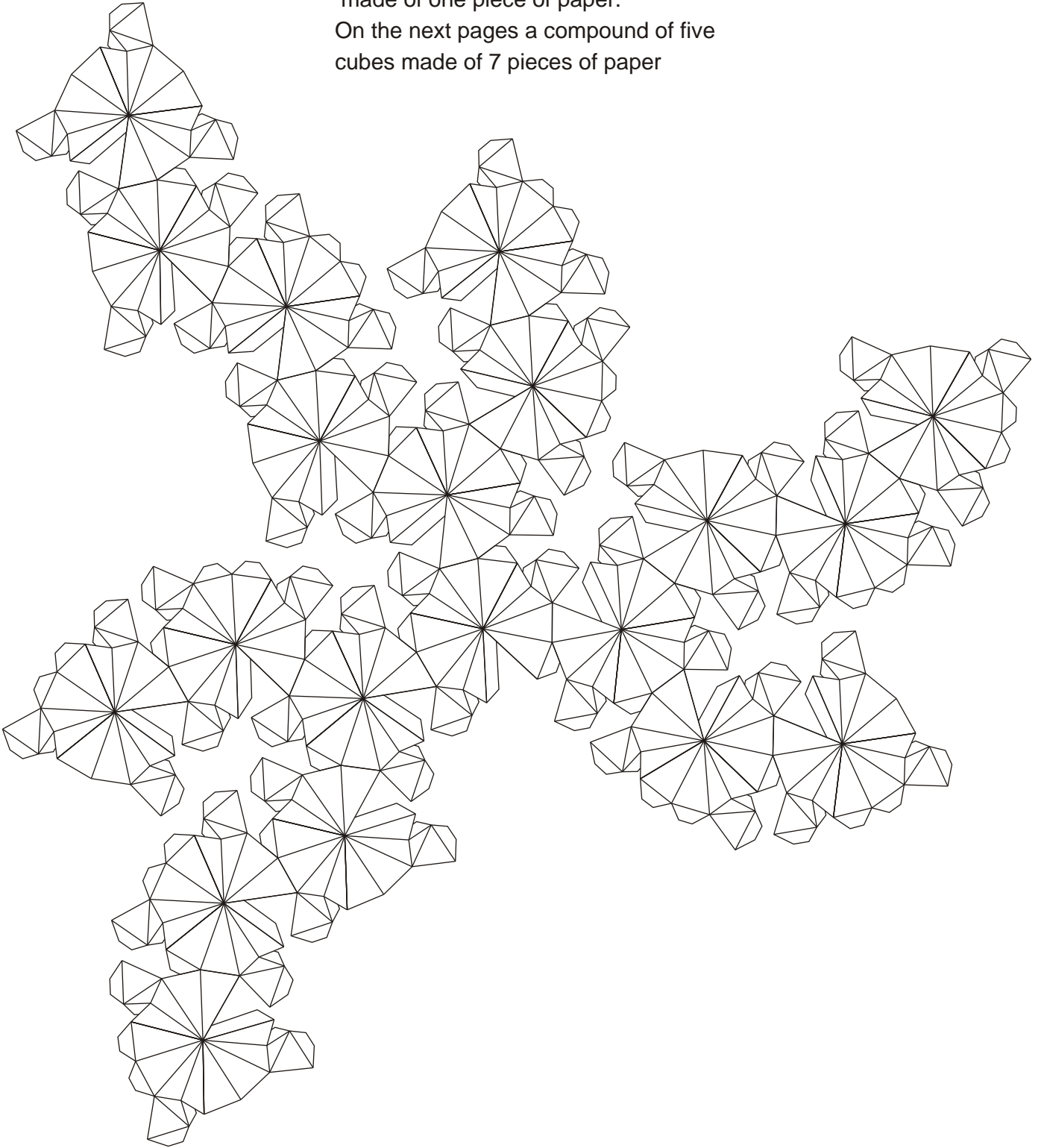



Instructions:

Cut and fold the piece(s) of paper.  
Glue the part without tabs around it last.  
This is the top part of piece F. This one  
opposites the center part of piece A.

Below an example of a part

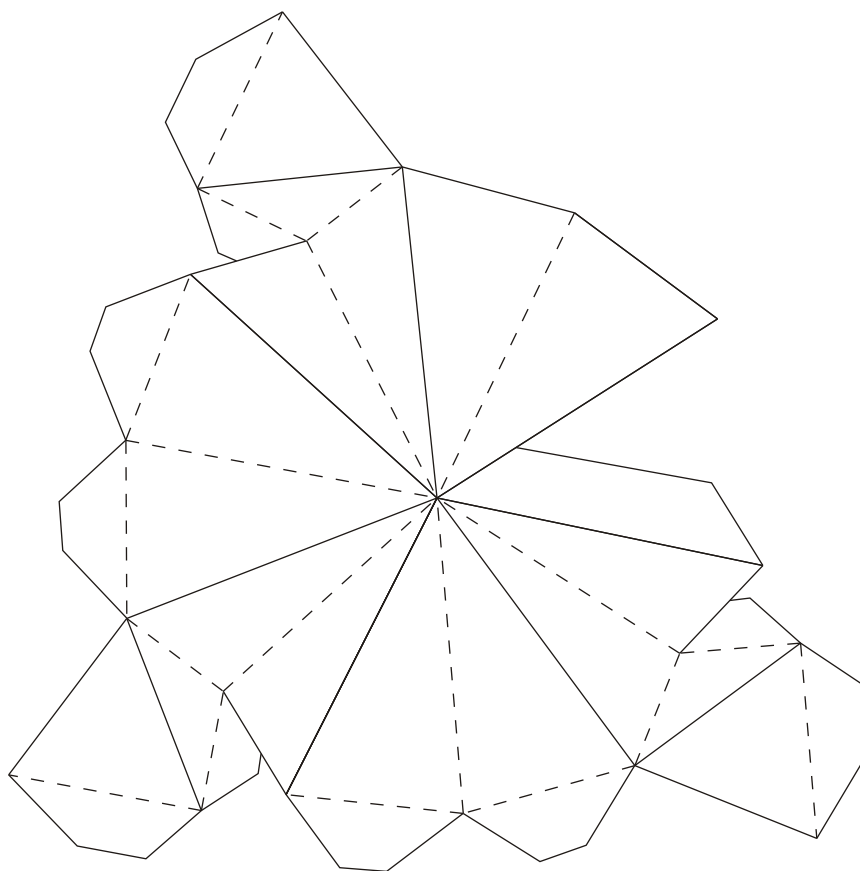

----- Fold forwards  
————— Fold backwards

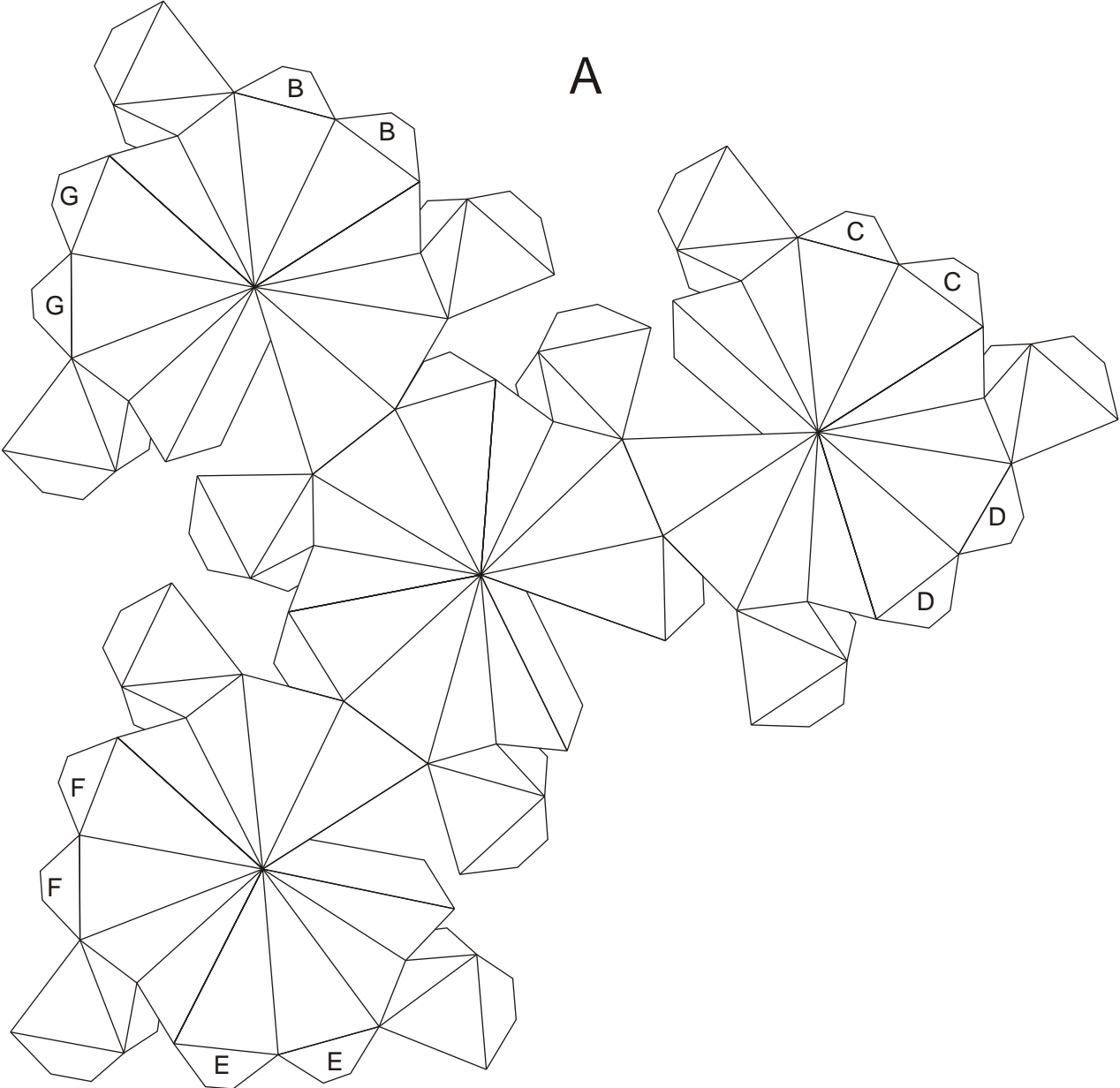

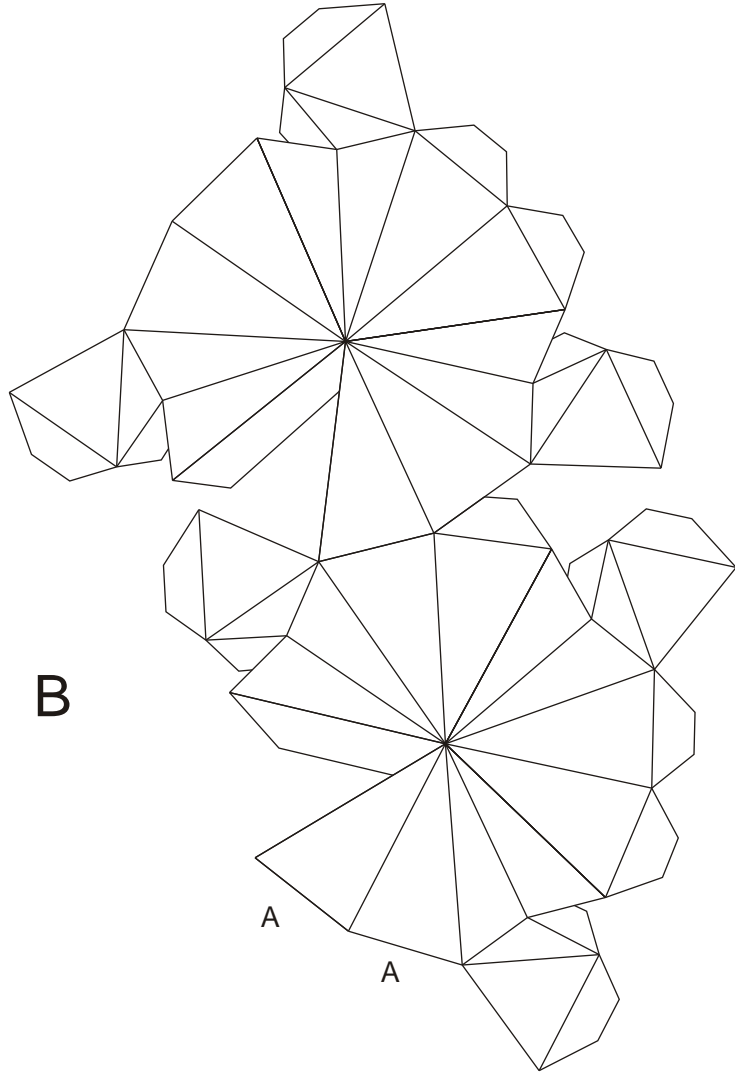

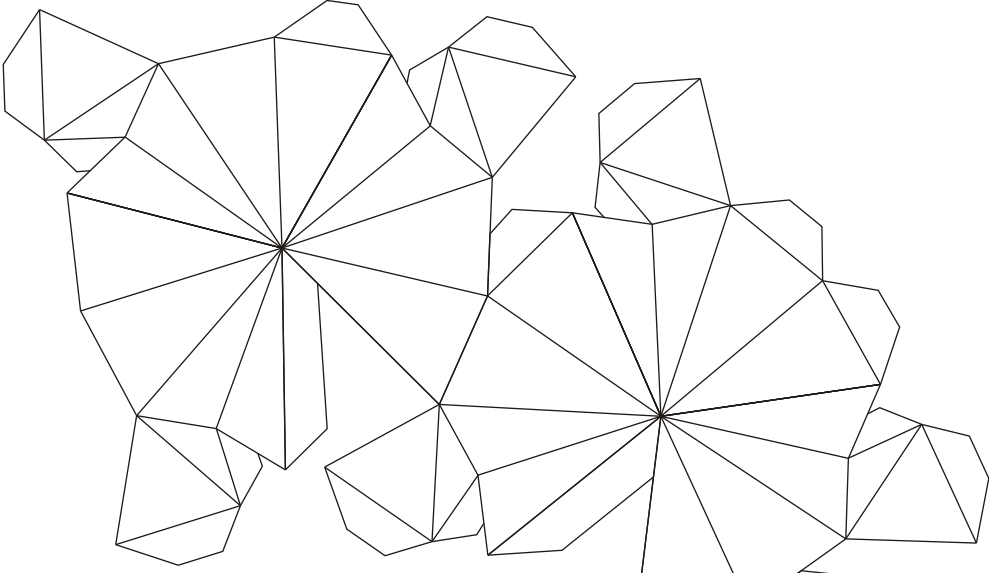

**C**

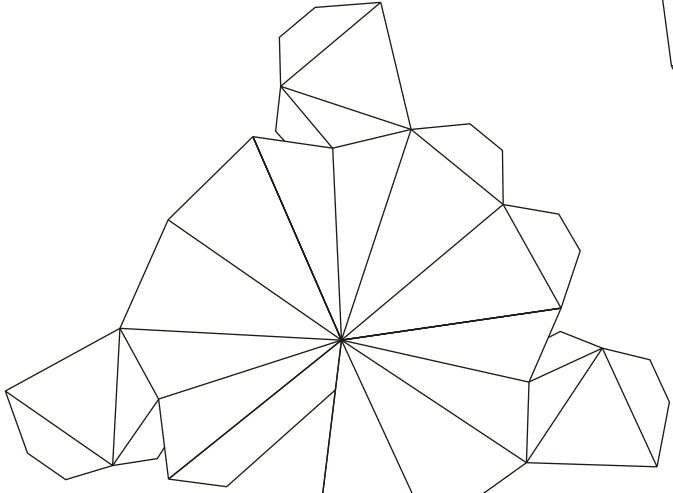
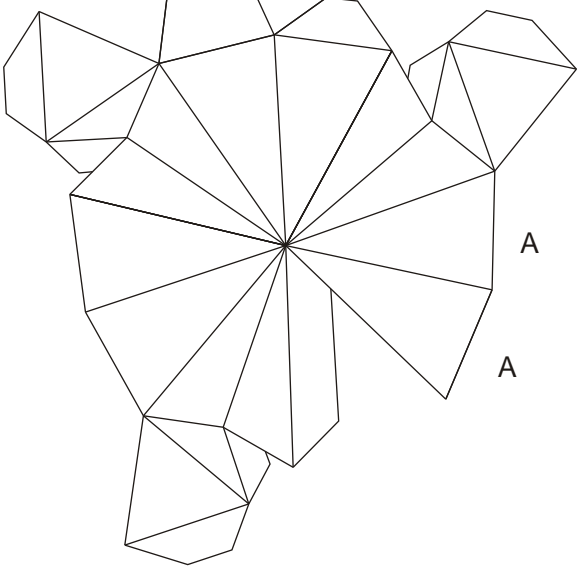

**D**

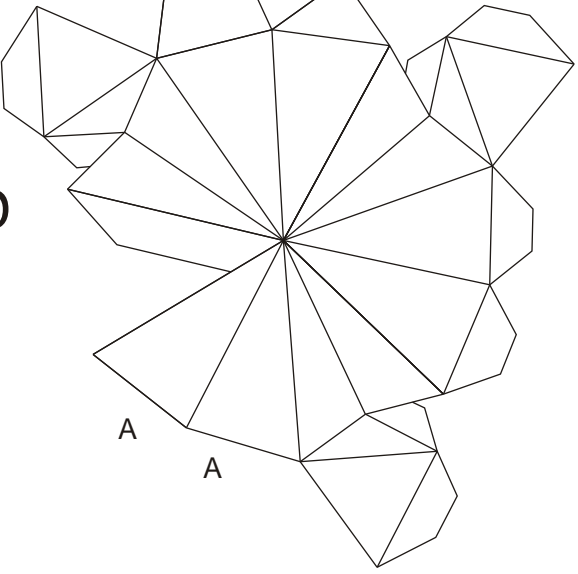

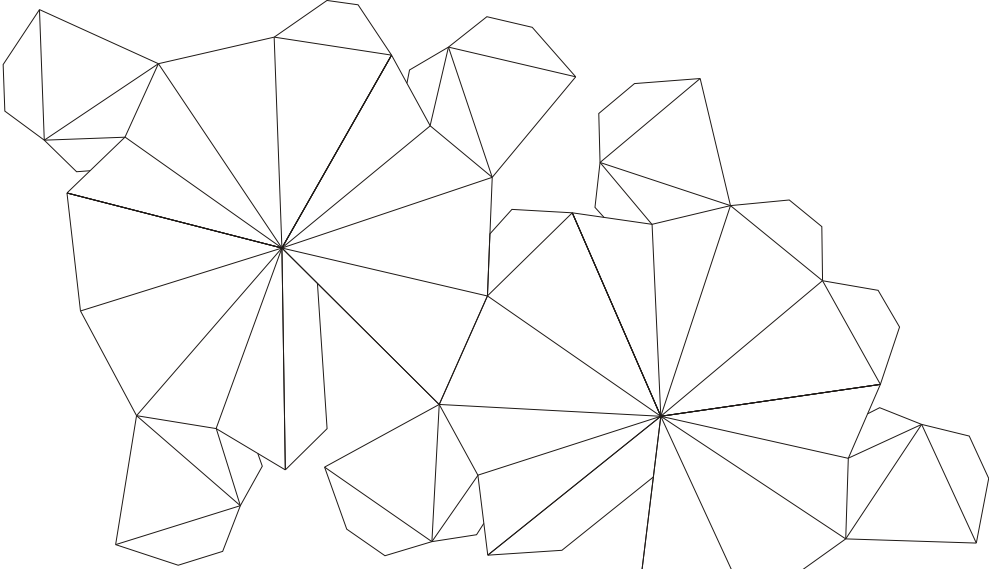

E

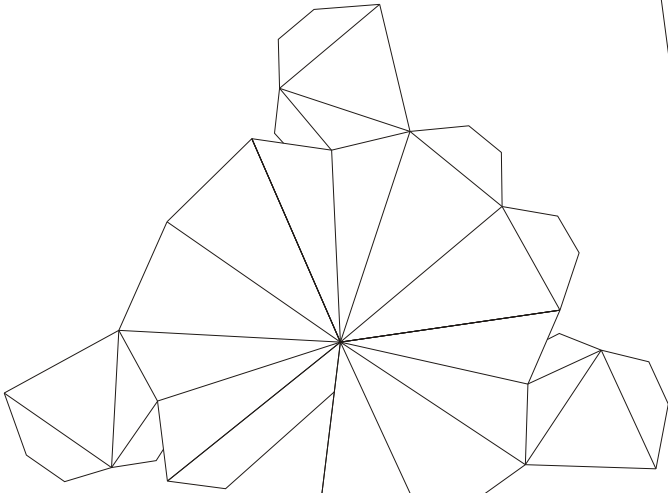
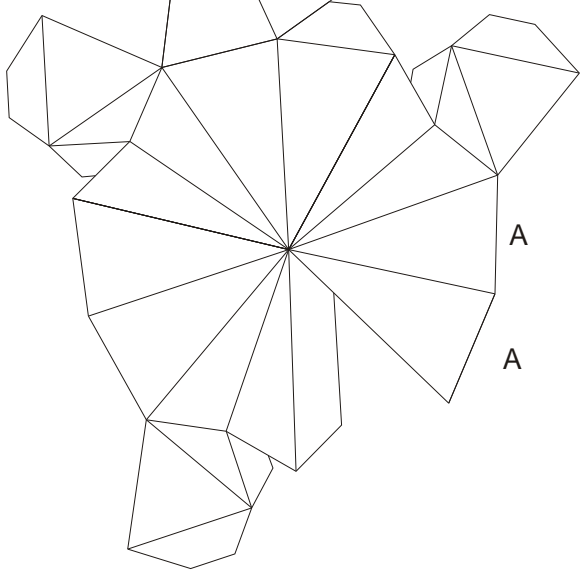

F

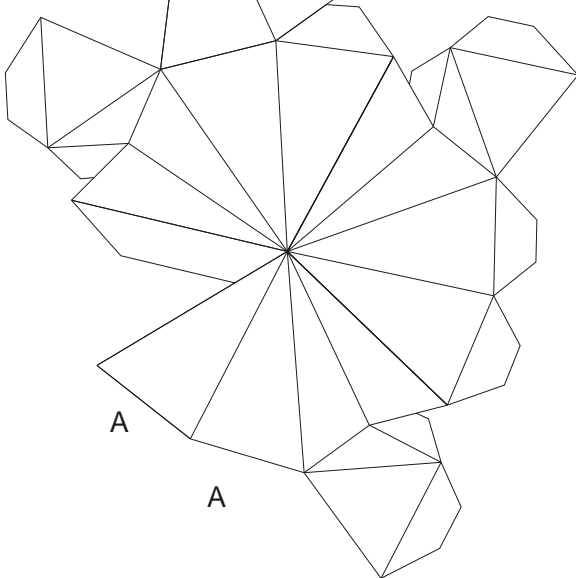

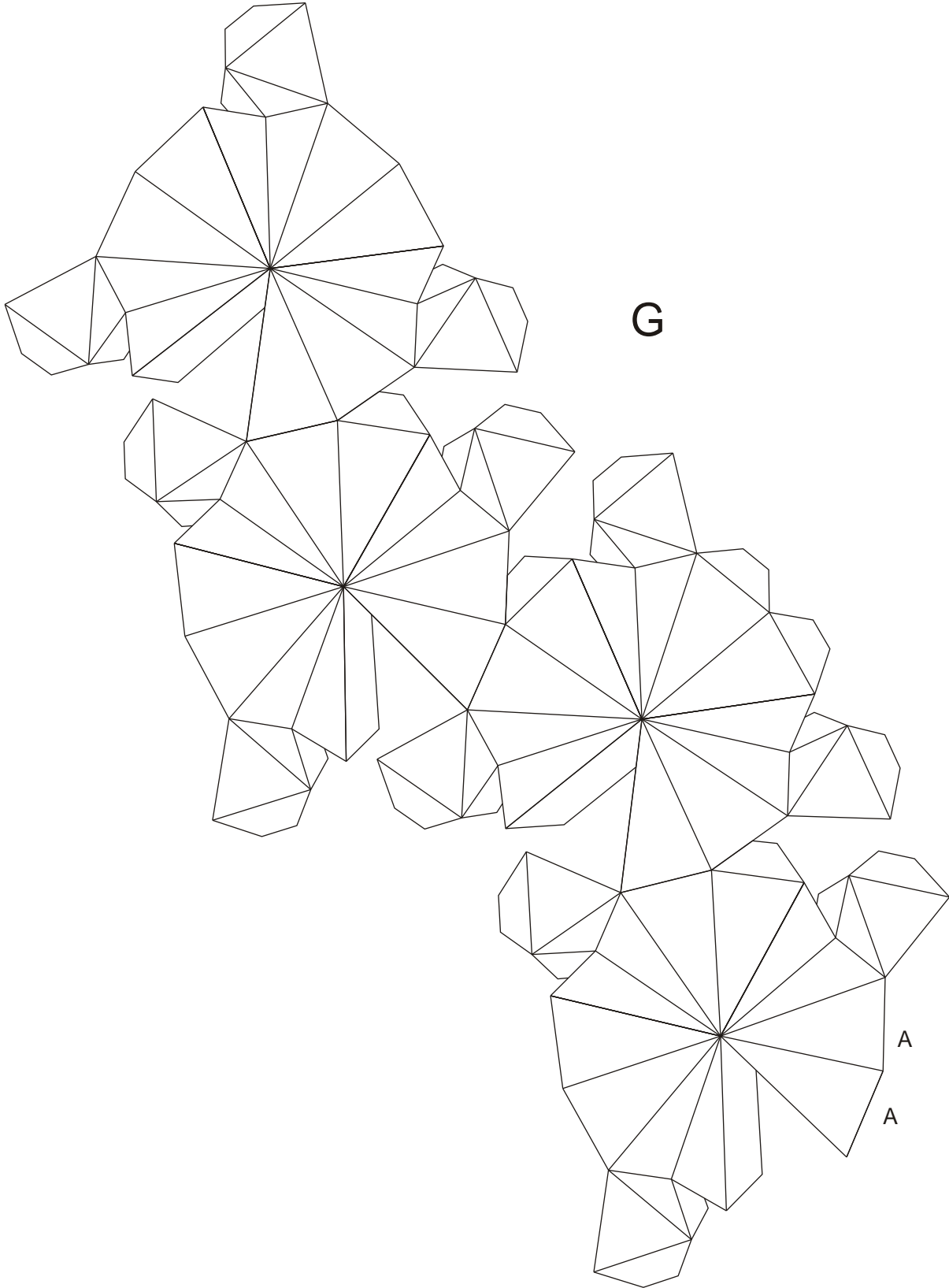

# Compound of five Octahedra

If you use paper in five different colors  
each octahedron has a different color

## Color 1

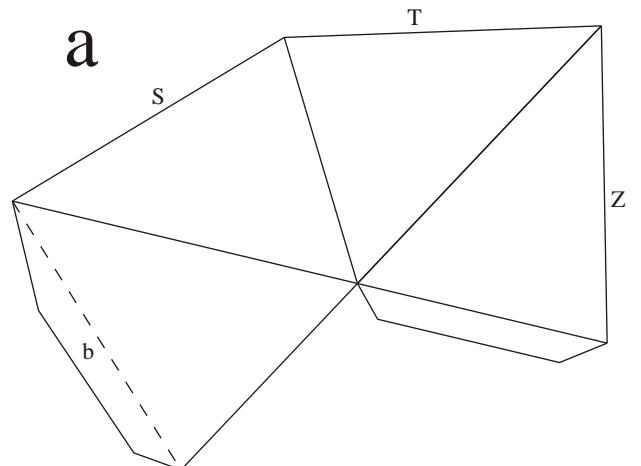
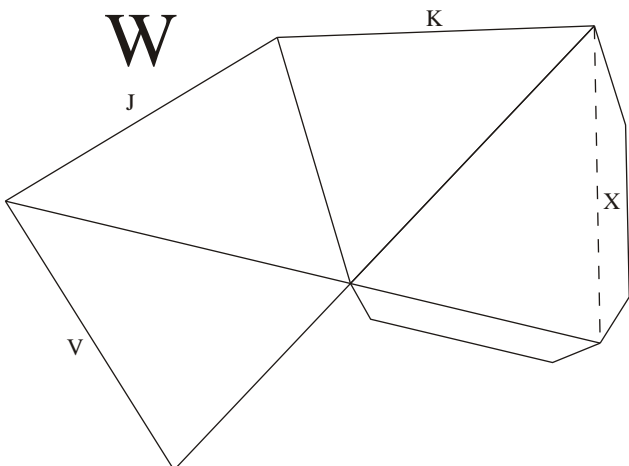
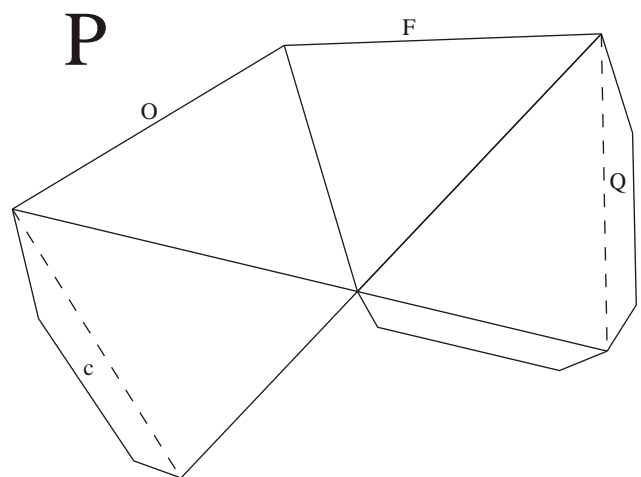
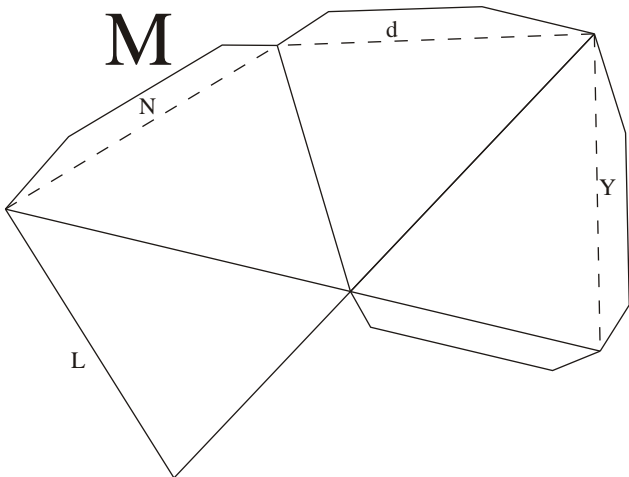
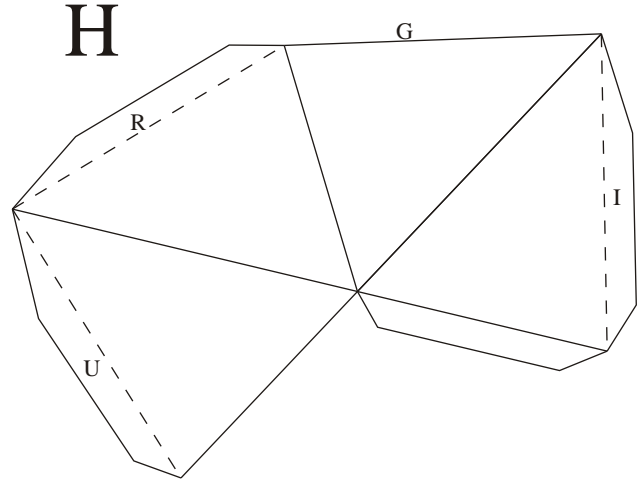
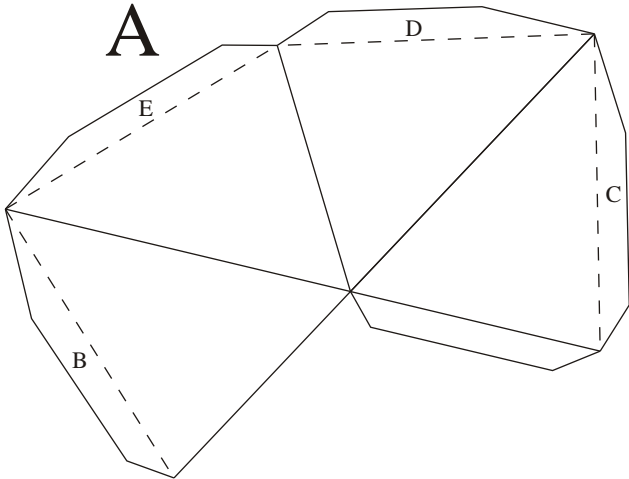

# Compound of five Octahedra

Color 2

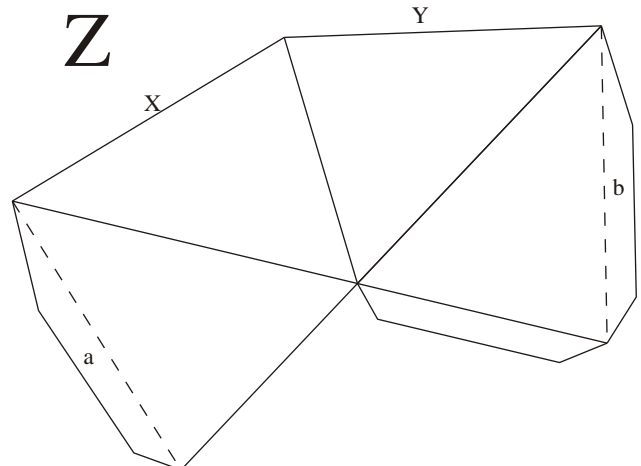
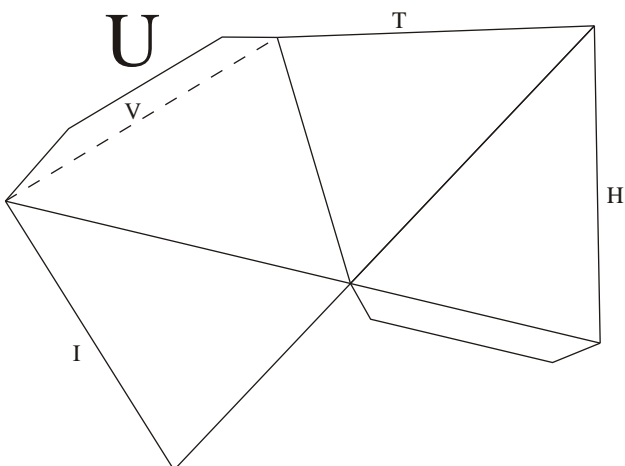
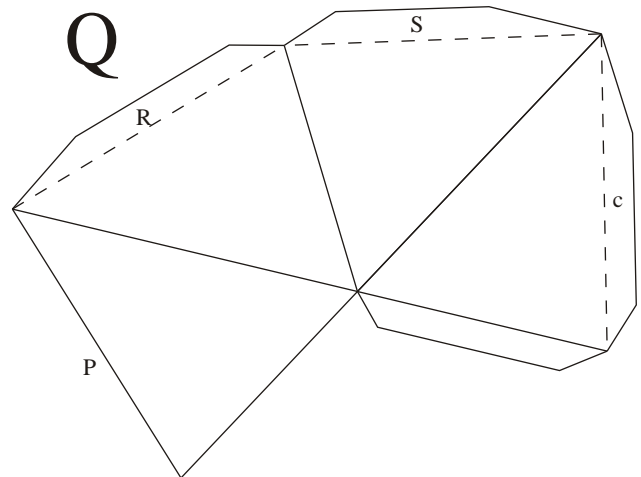
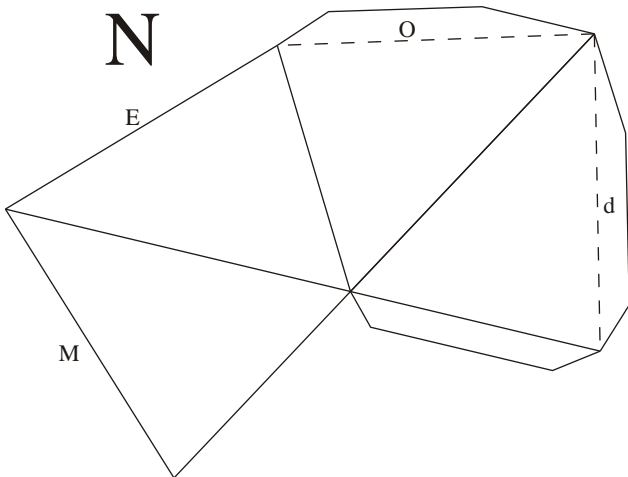
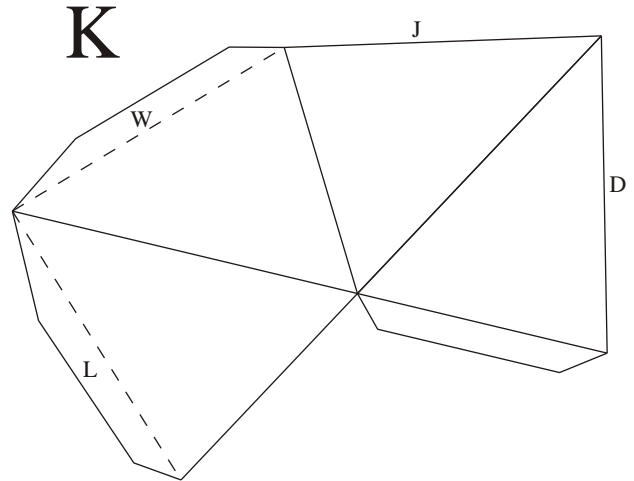
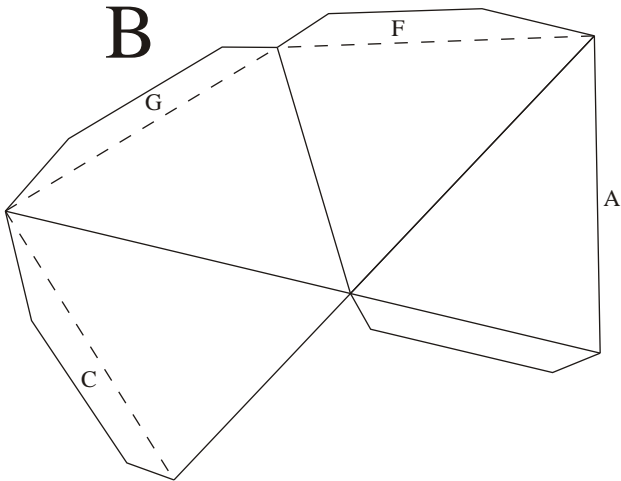



# Compound of five Octahedra

## Color 3

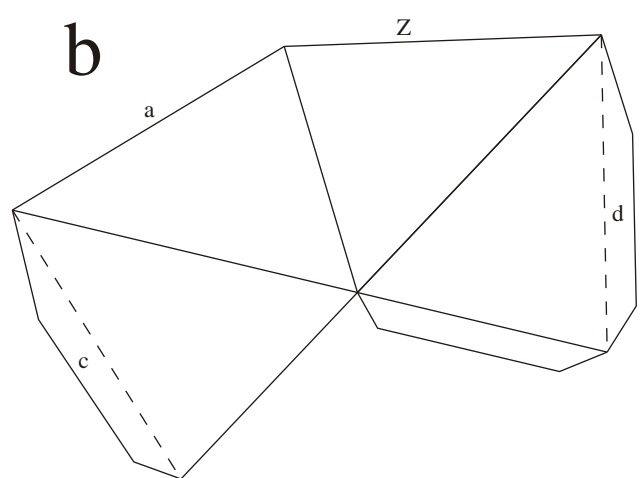
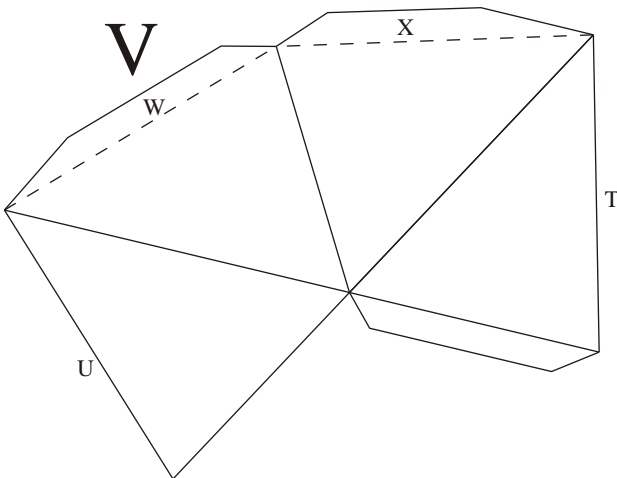
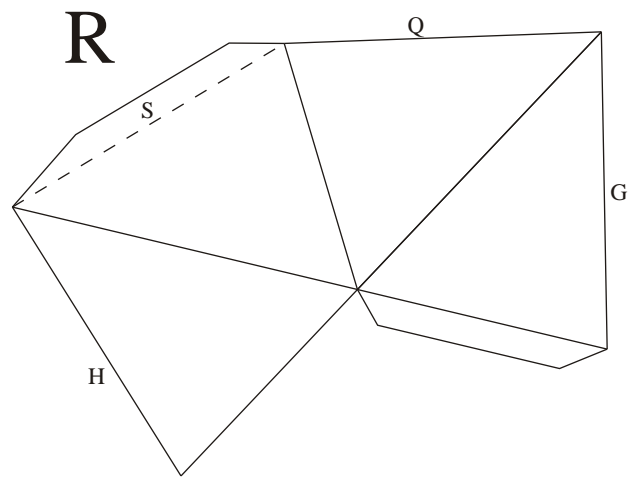
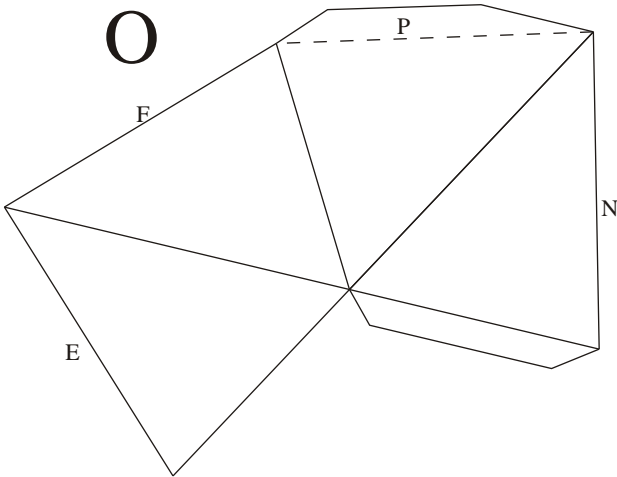
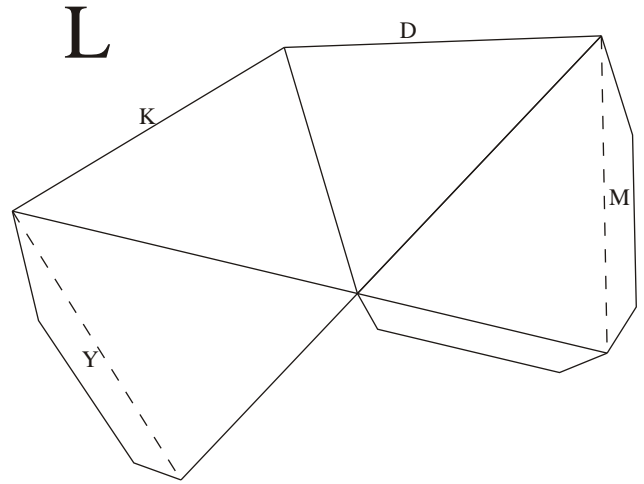
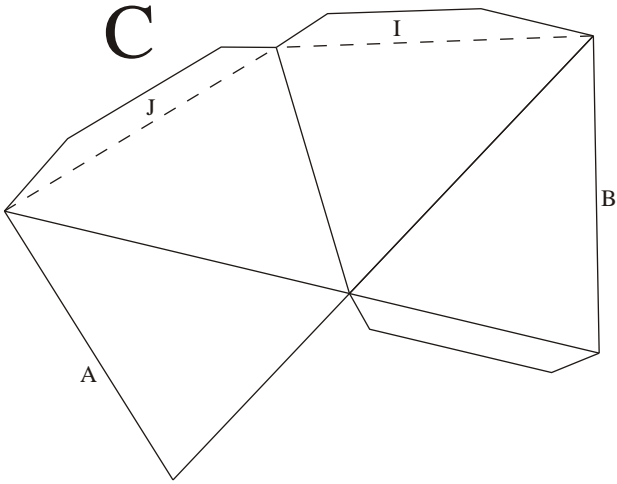

# Compound of five Octahedra

Color 4

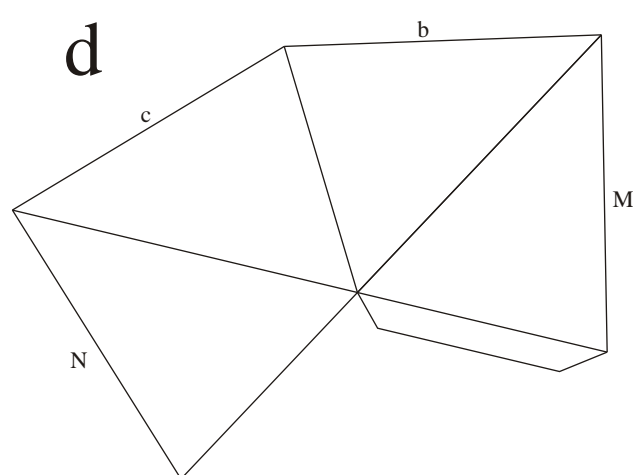
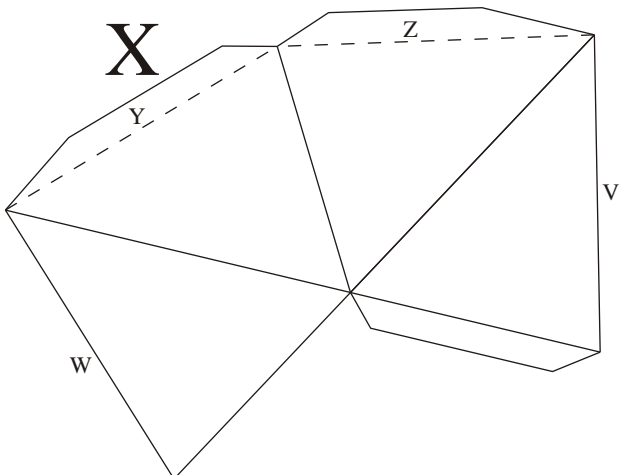
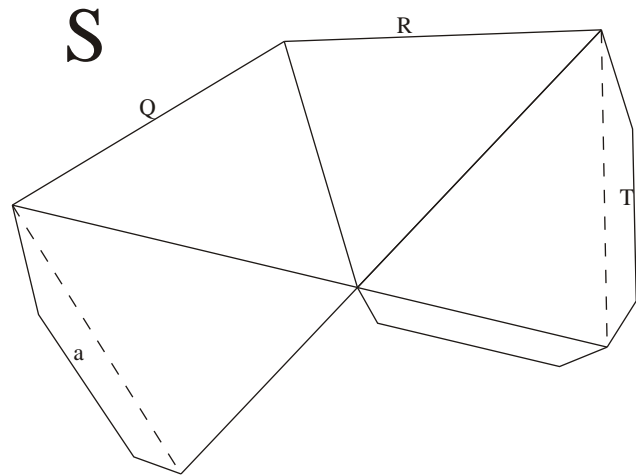
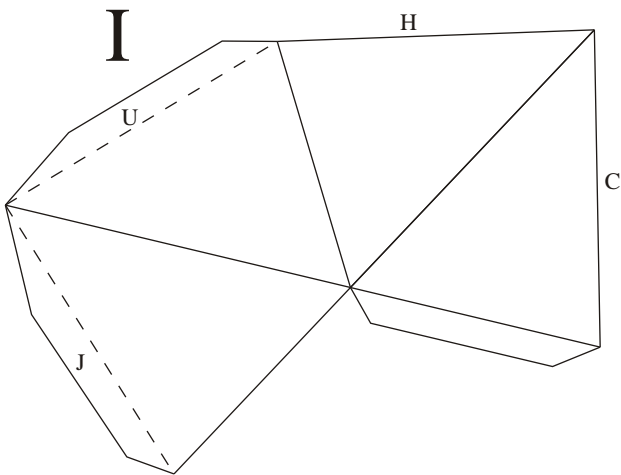
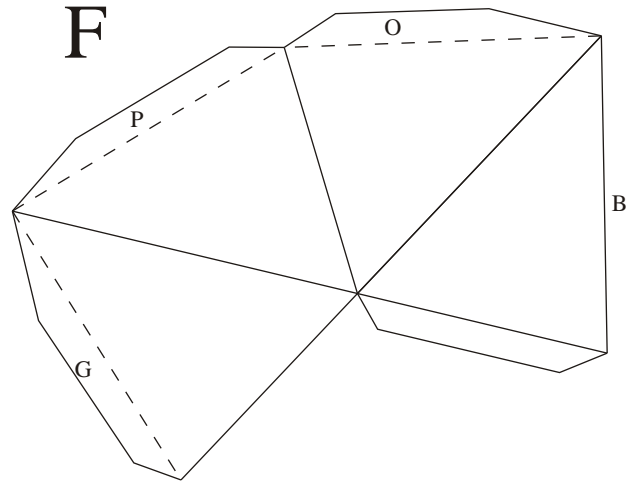
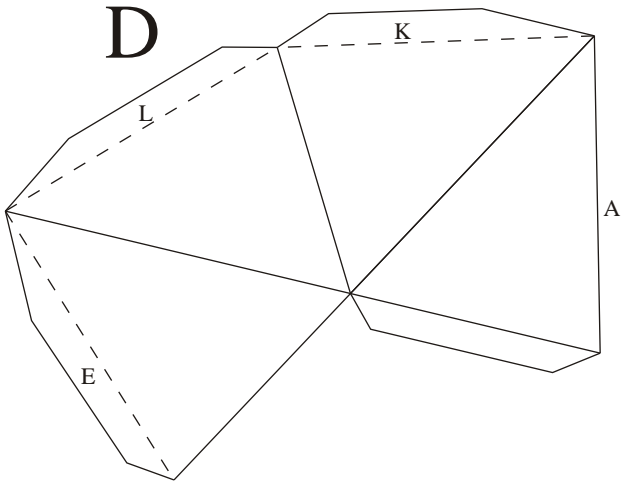

# Compound of five Octahedra

Color 5

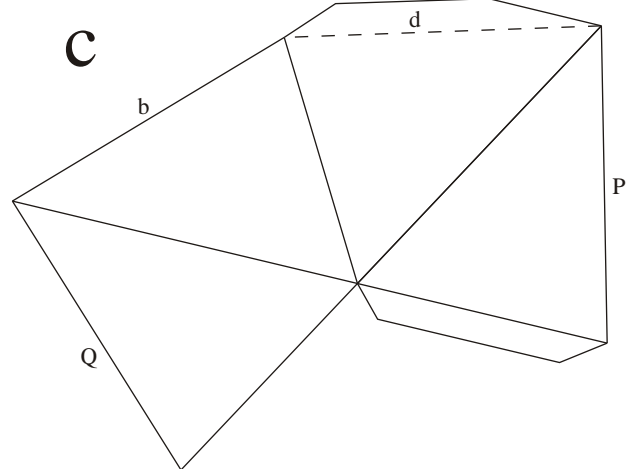
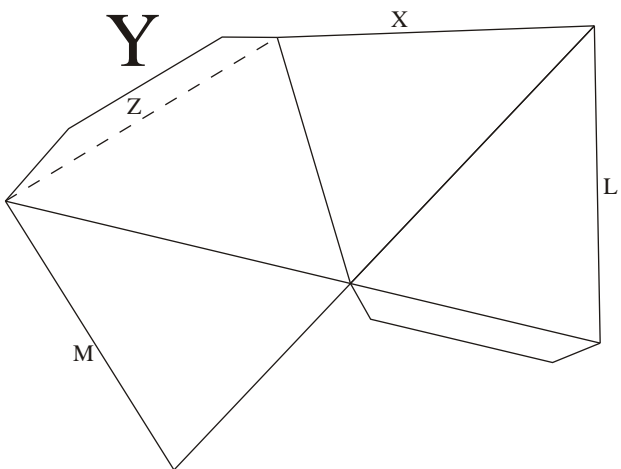
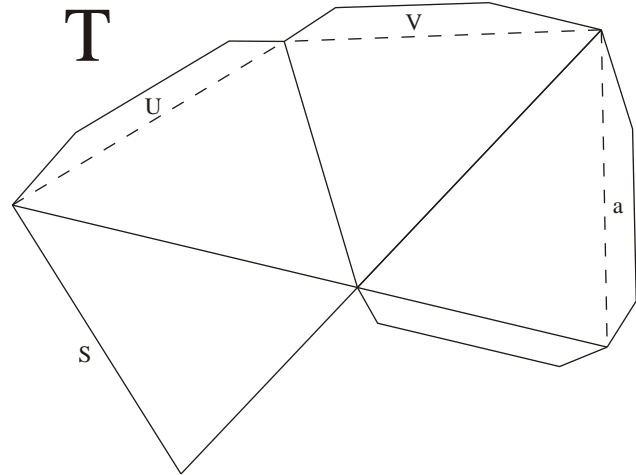
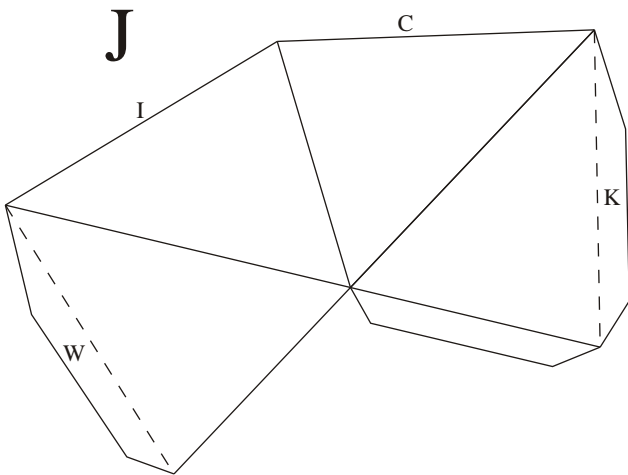
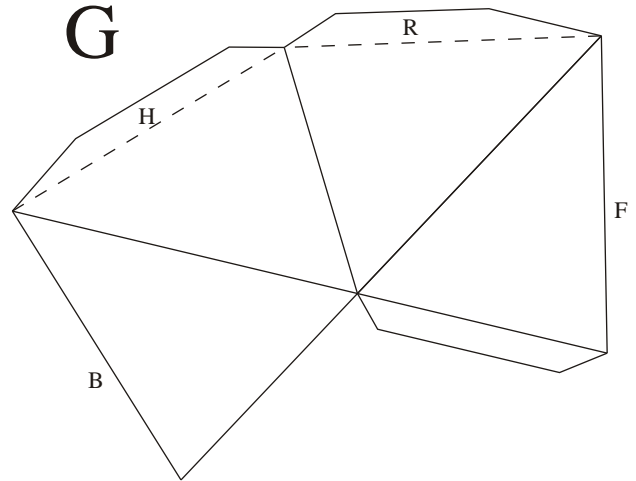
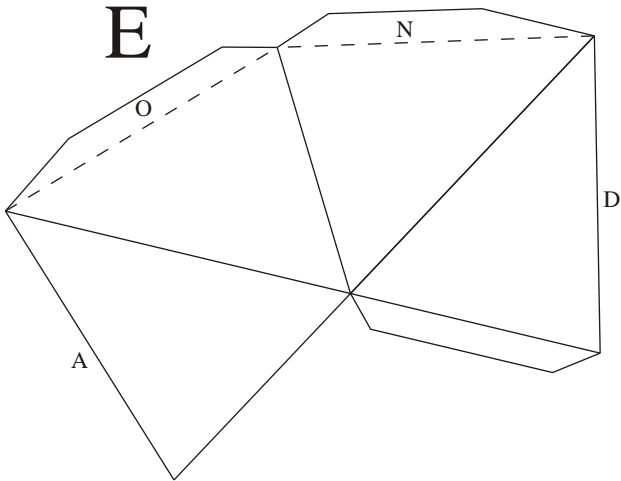

*Pyramids*

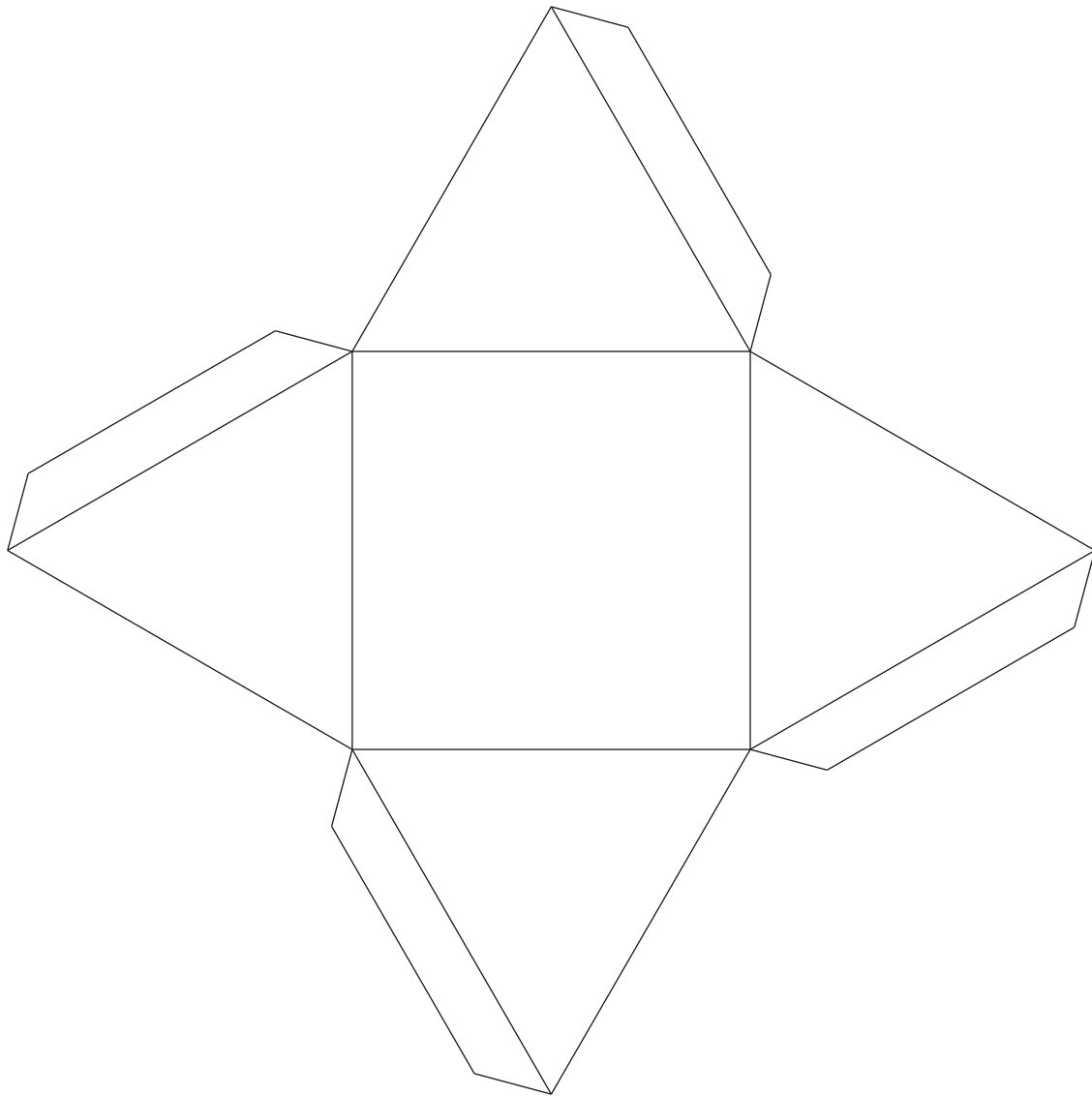
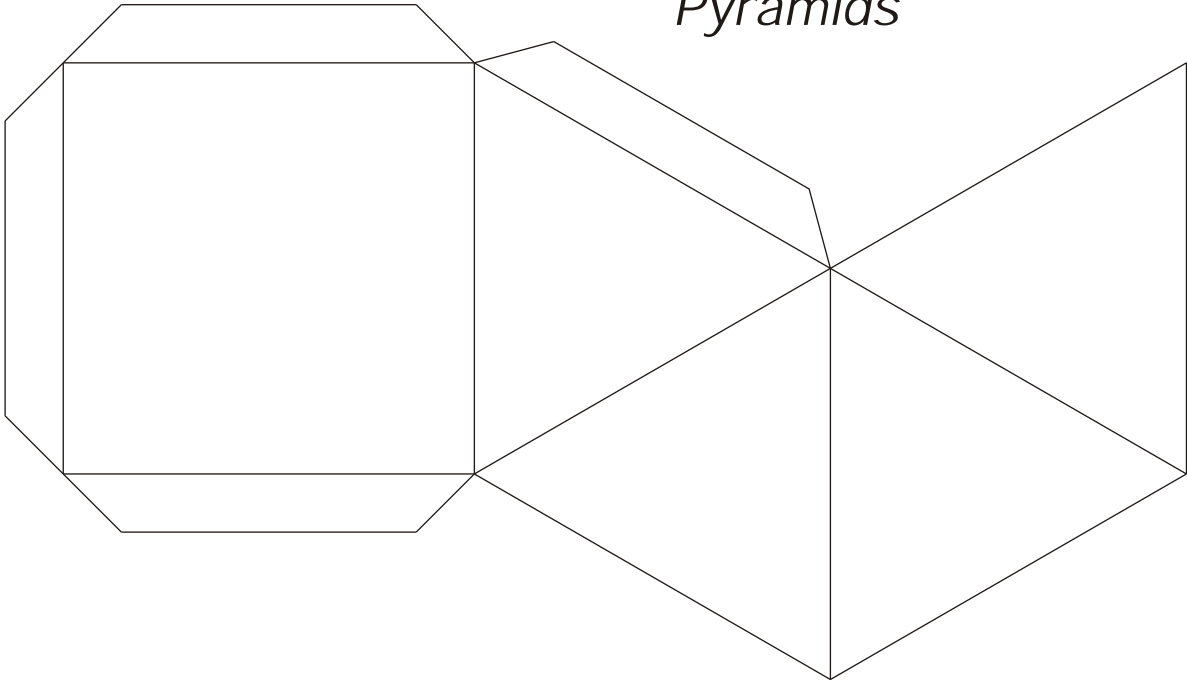

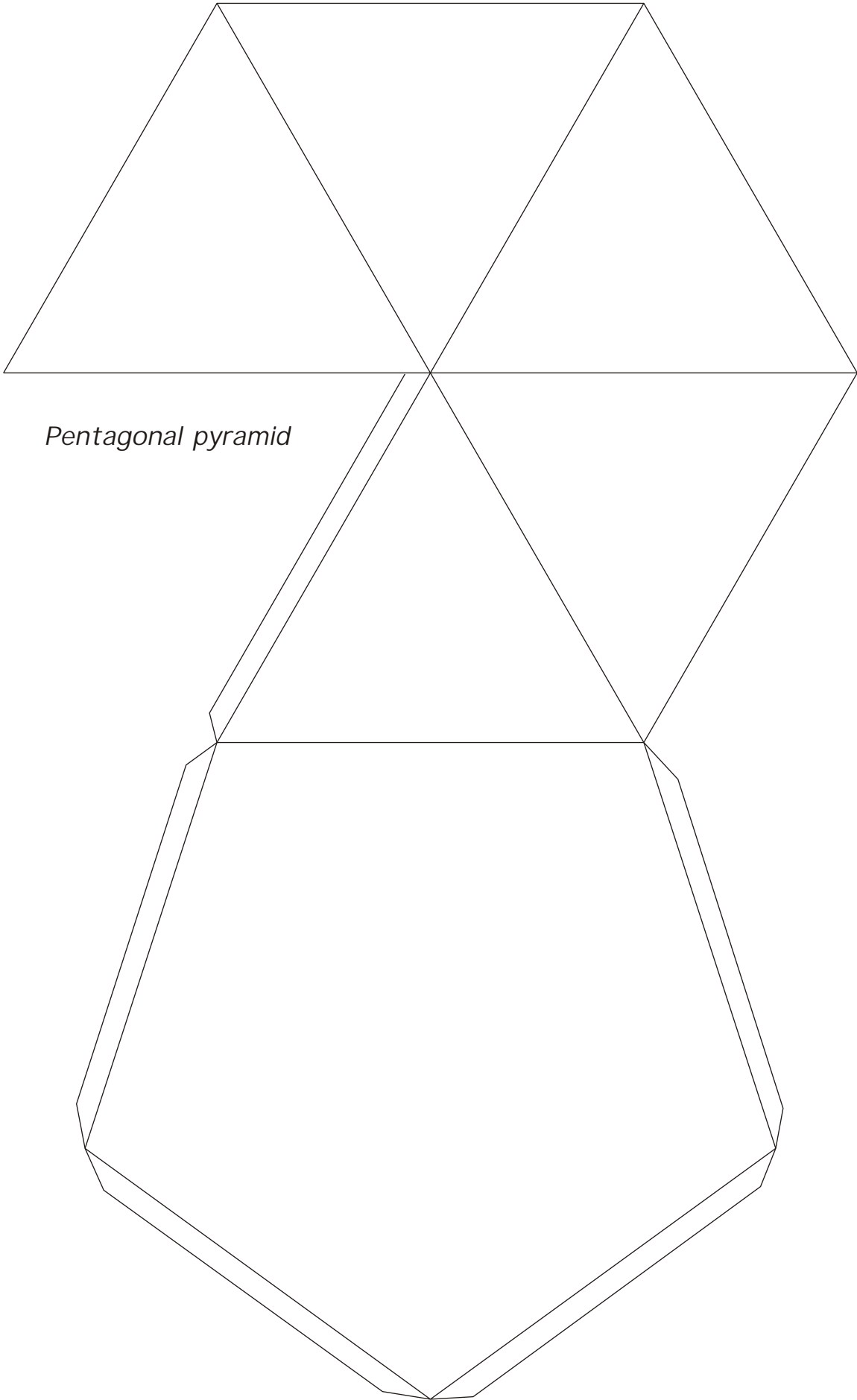

*Pentagonal pyramid*

*Decahedron*

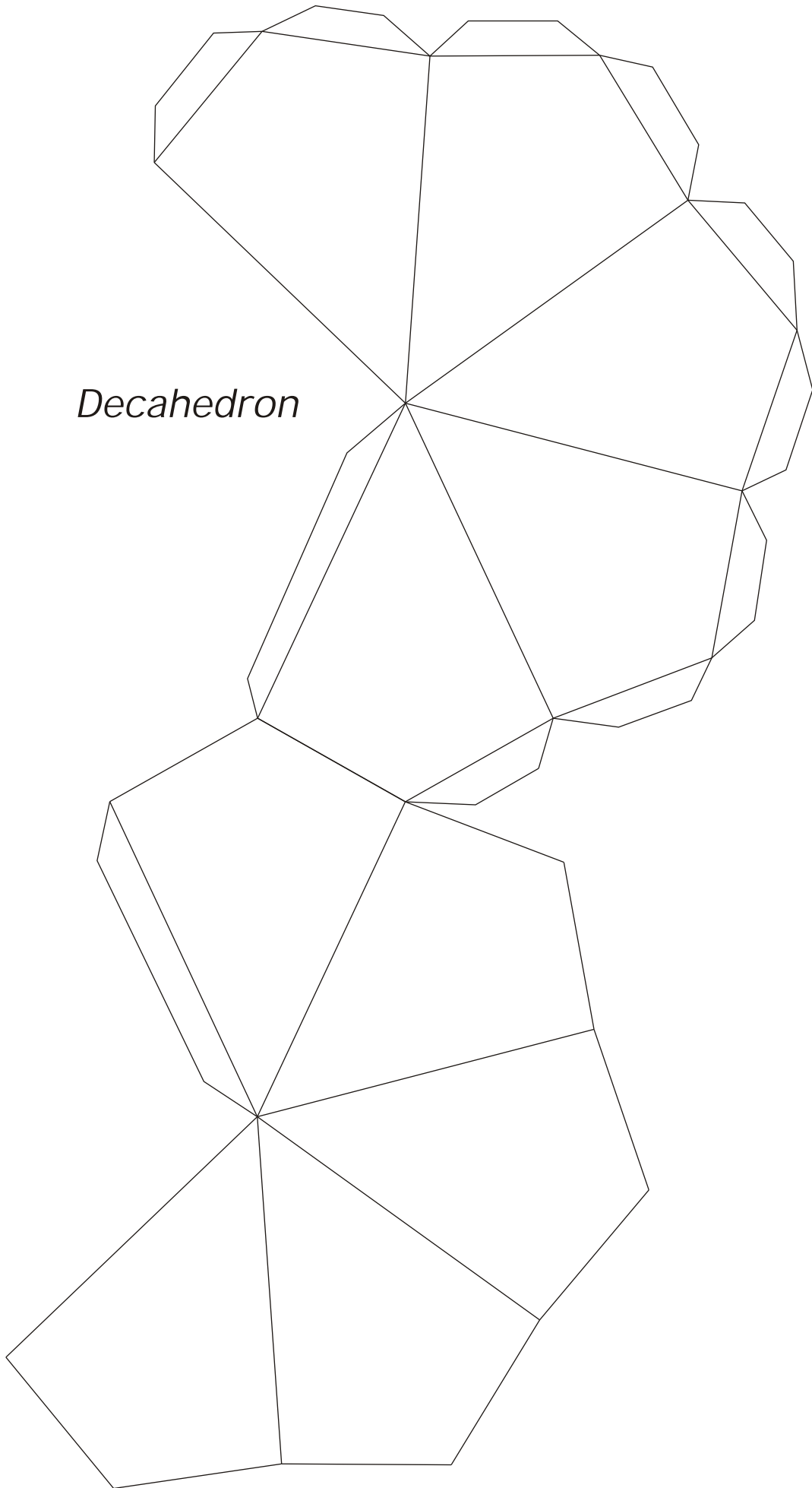

Rhombic Dodecahedron

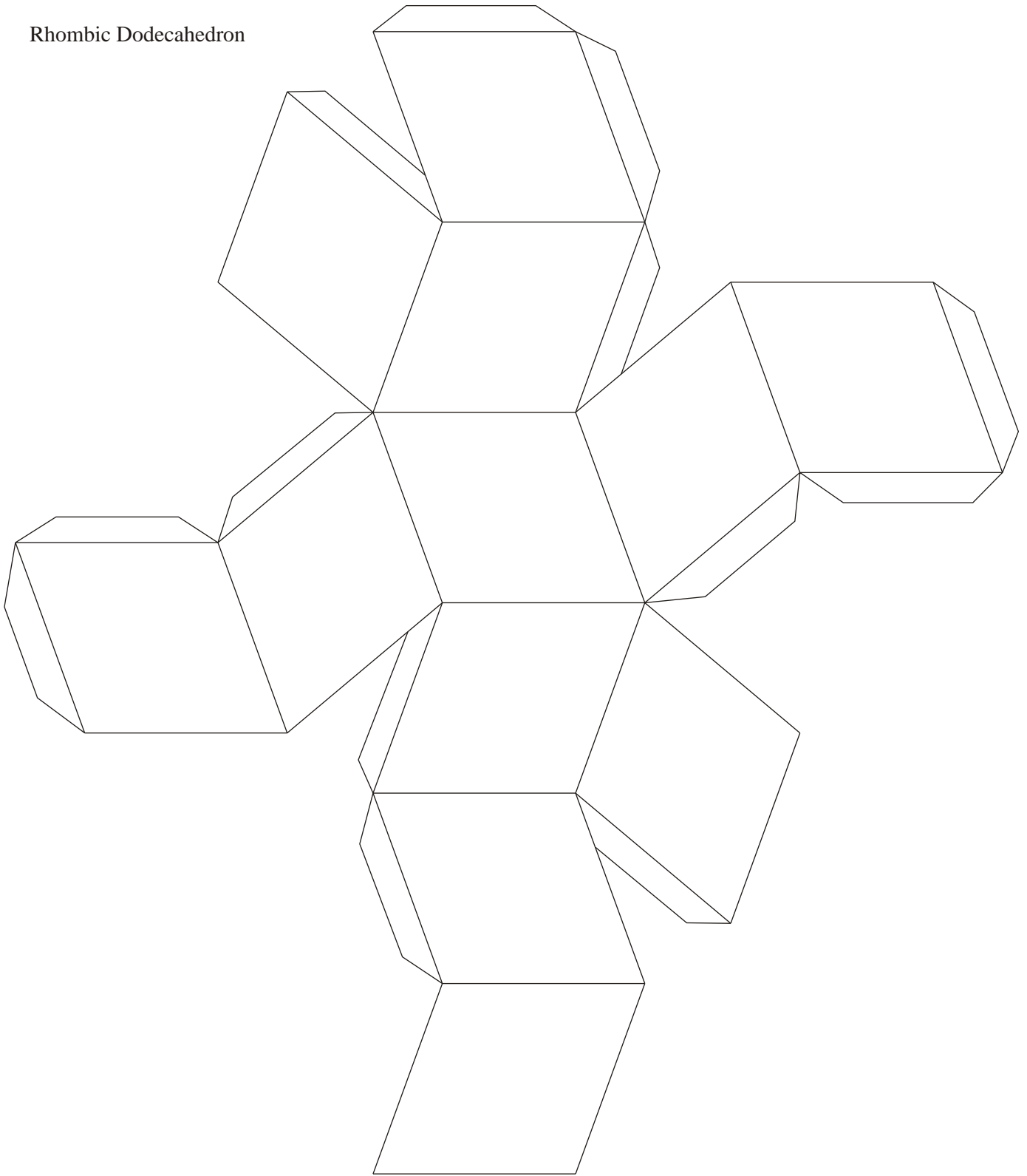

*Great Rhombihexacron*

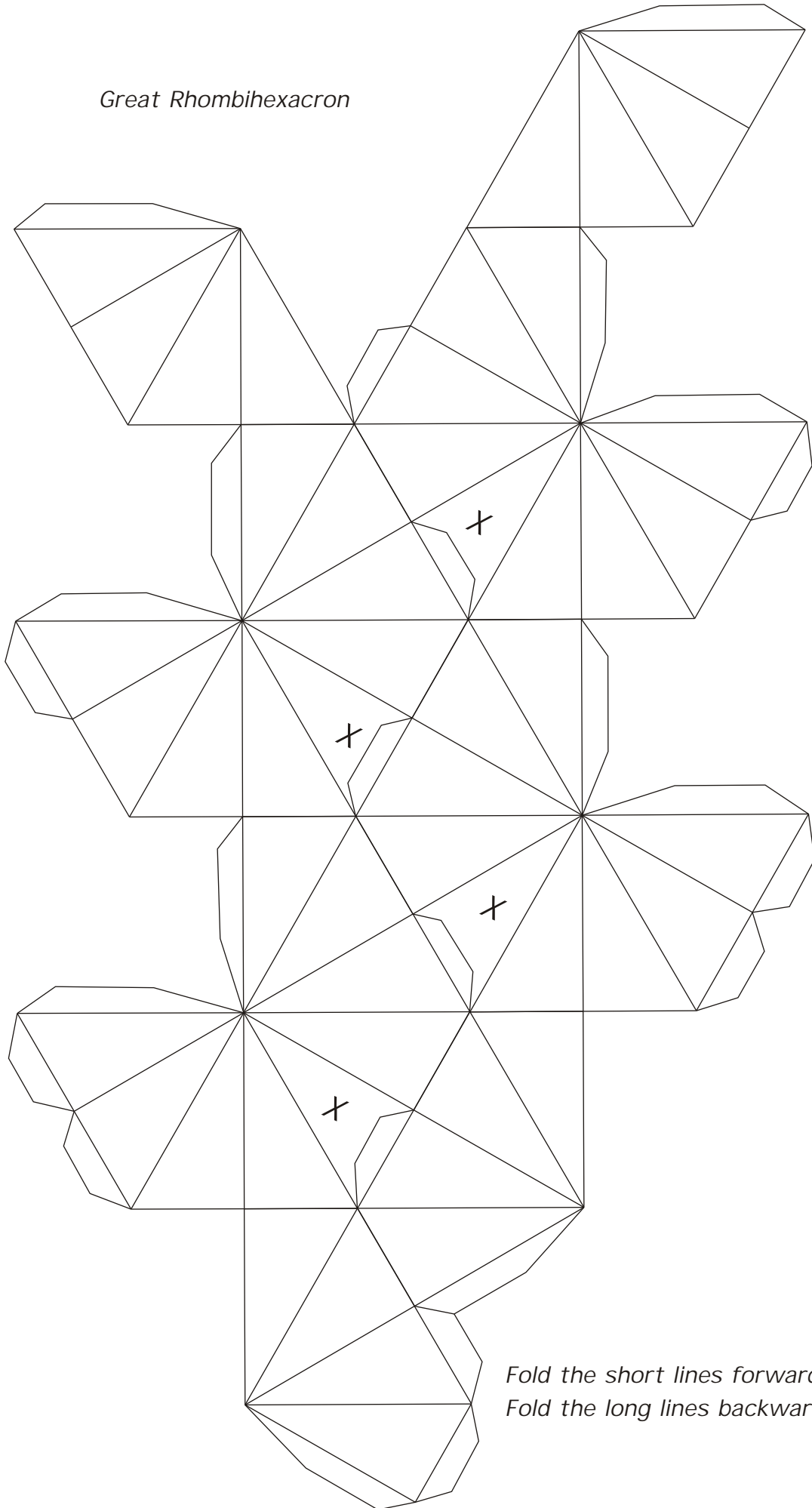

*Fold the short lines forwards  
Fold the long lines backwards*



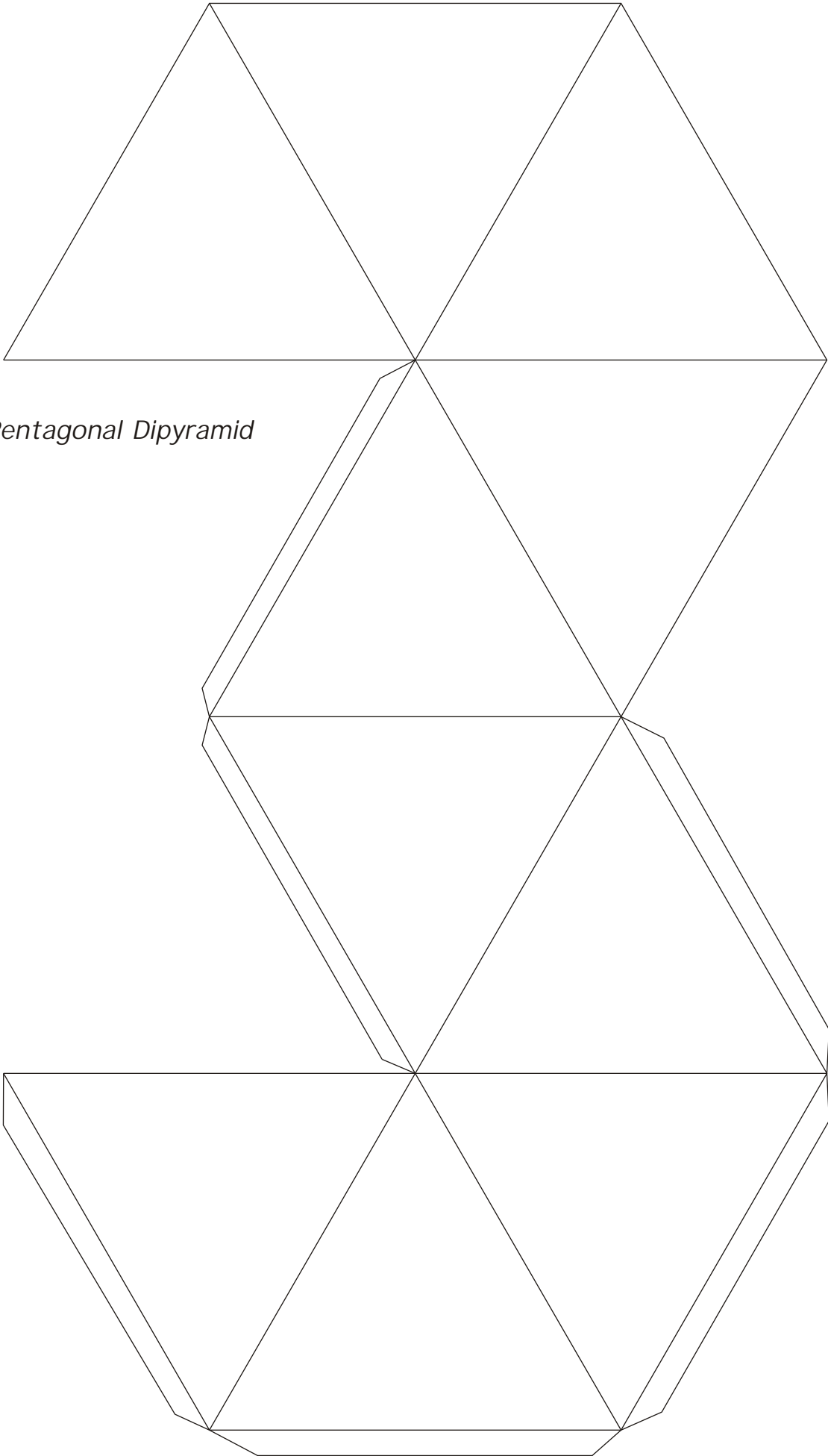

*Pentagonal Dipyramid*

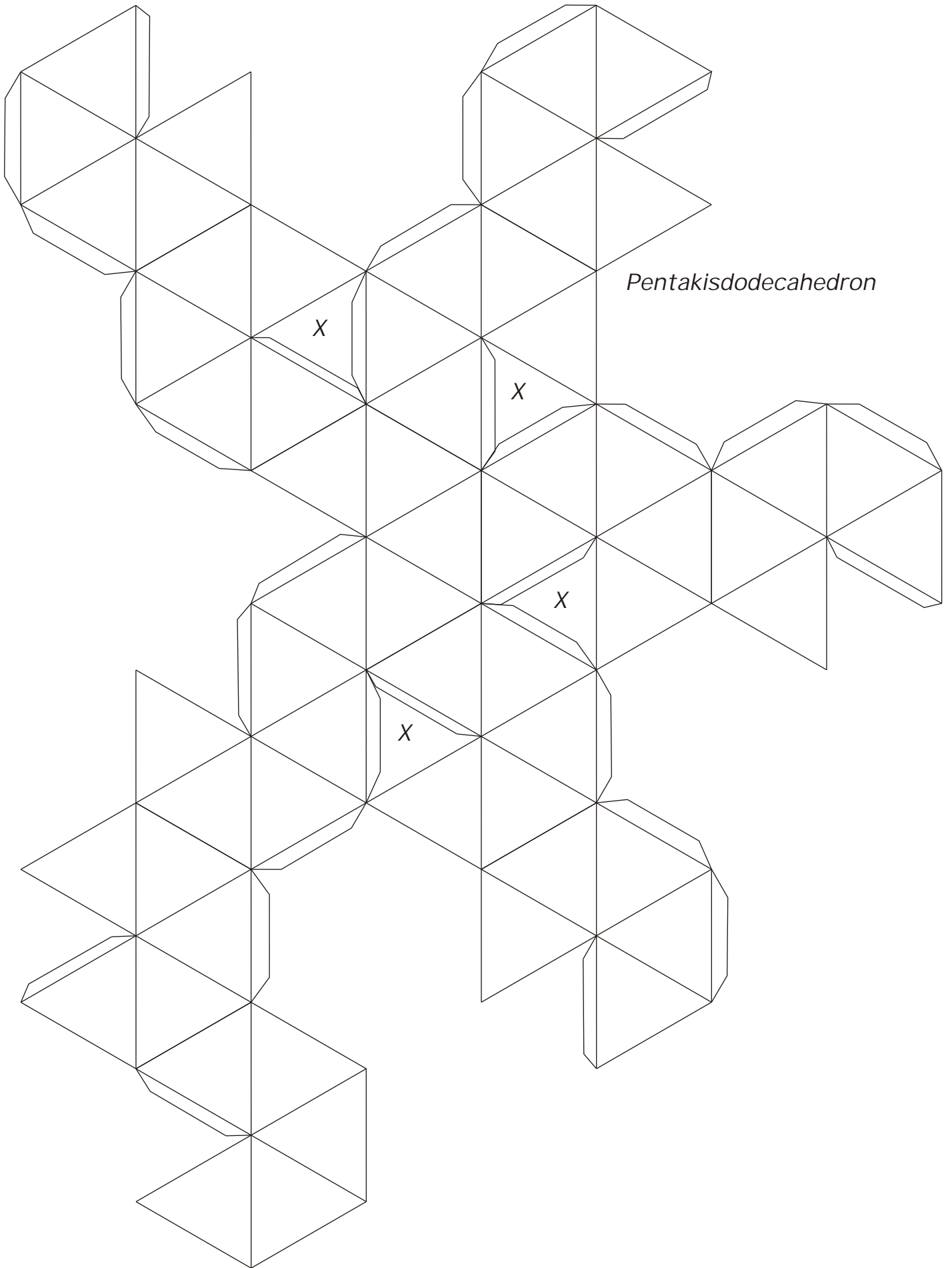

*Pentakisdodecahedron*

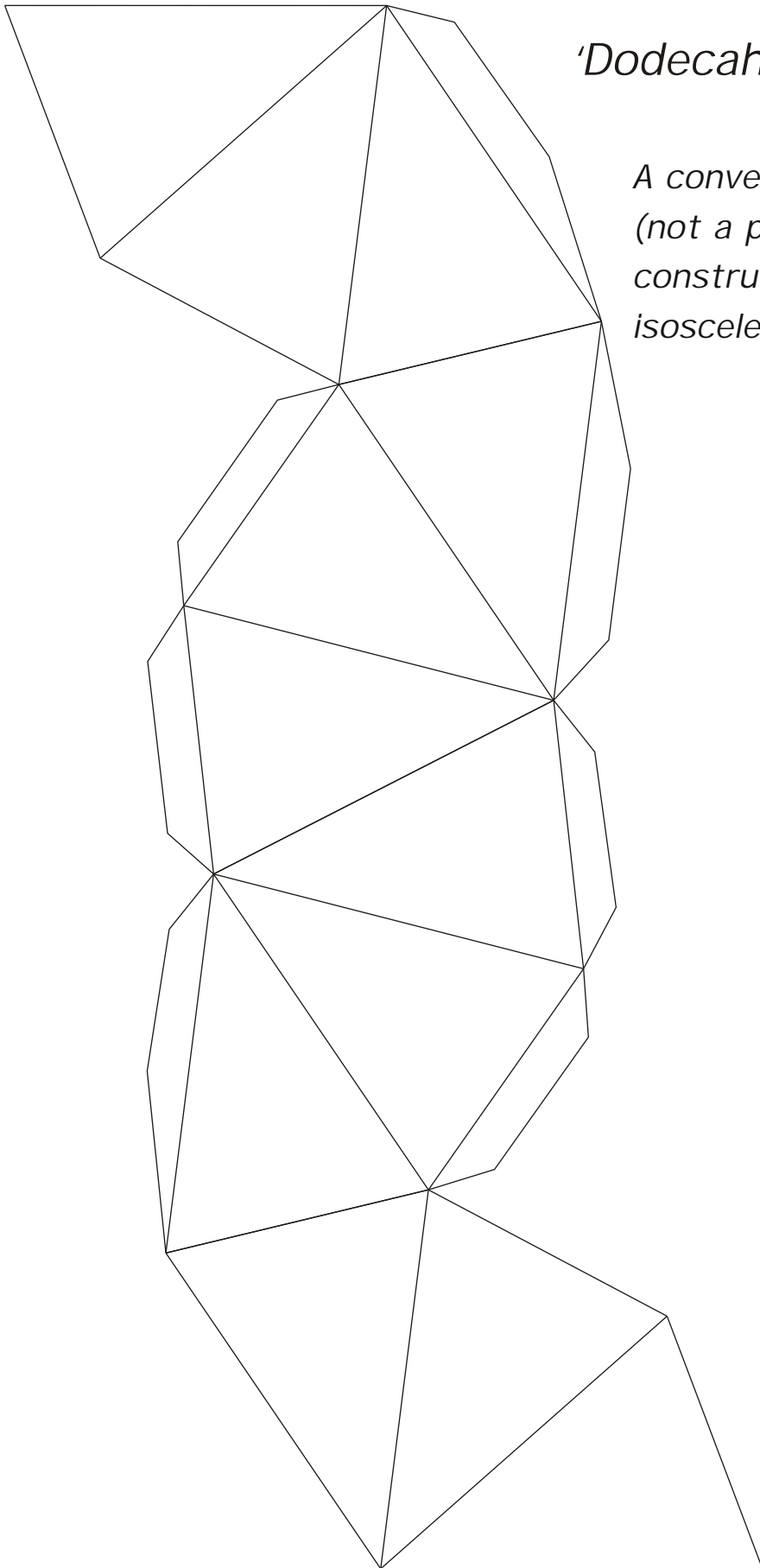

## *'Dodecahedron'*

*A convex dodecahedron  
(not a platonic solid)  
constructed of 12  
isosceles triangles*

*Hexakaidecahedron*

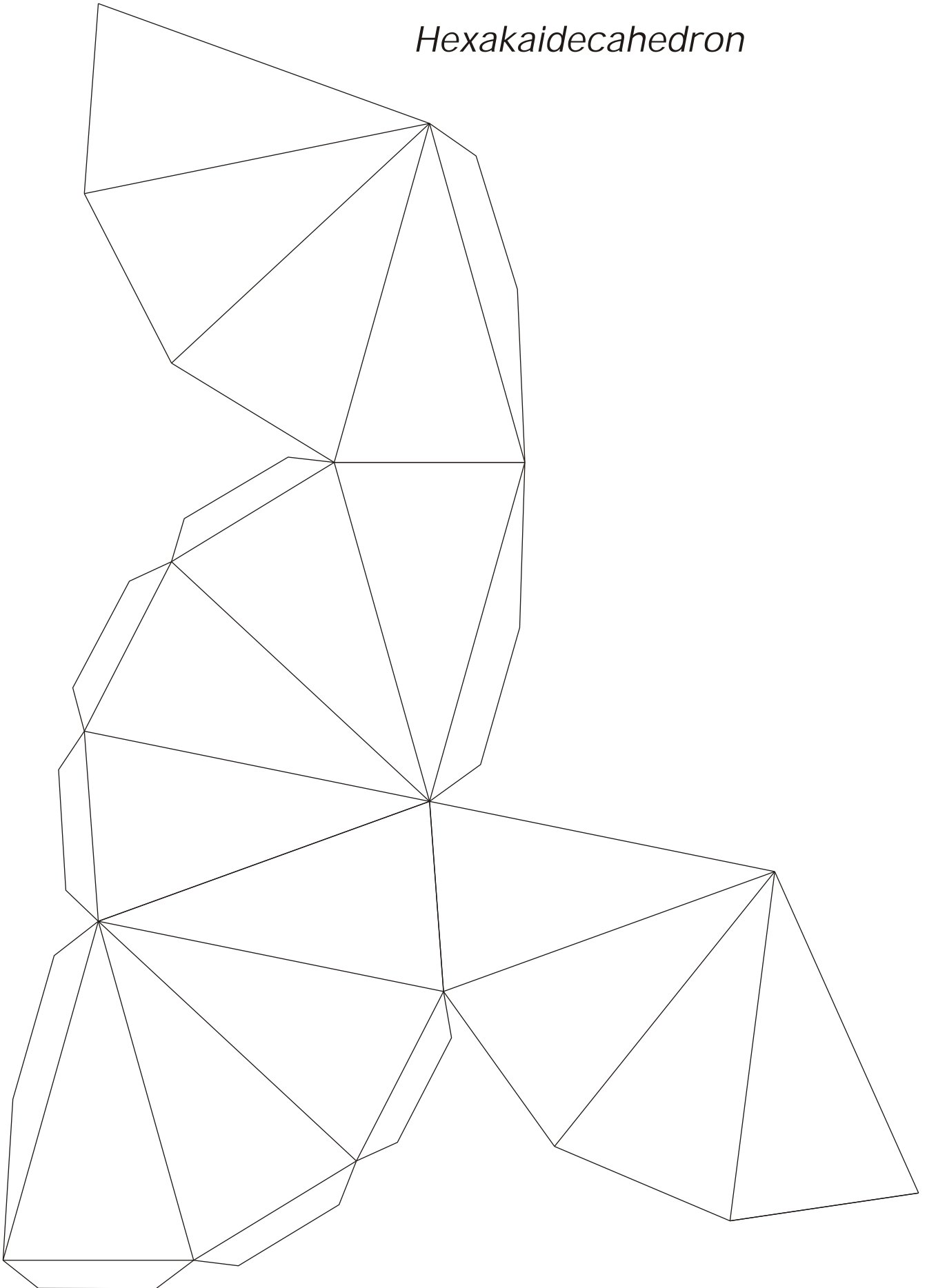

*'Icosahedron'*

A convex icosahedron  
(not a platonic solid)  
constructed of 20  
isosceles triangles

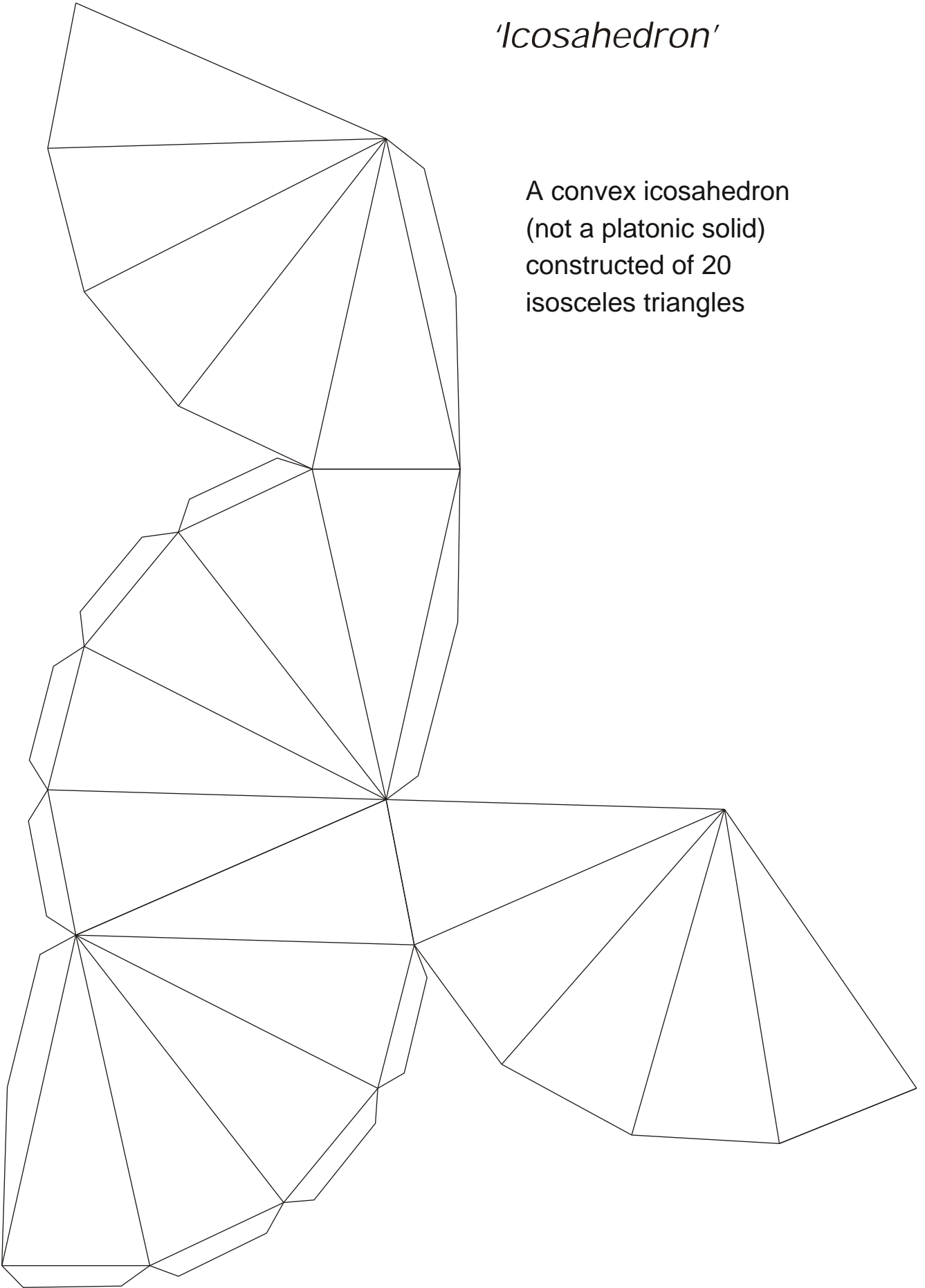

*Icositetrahedron*

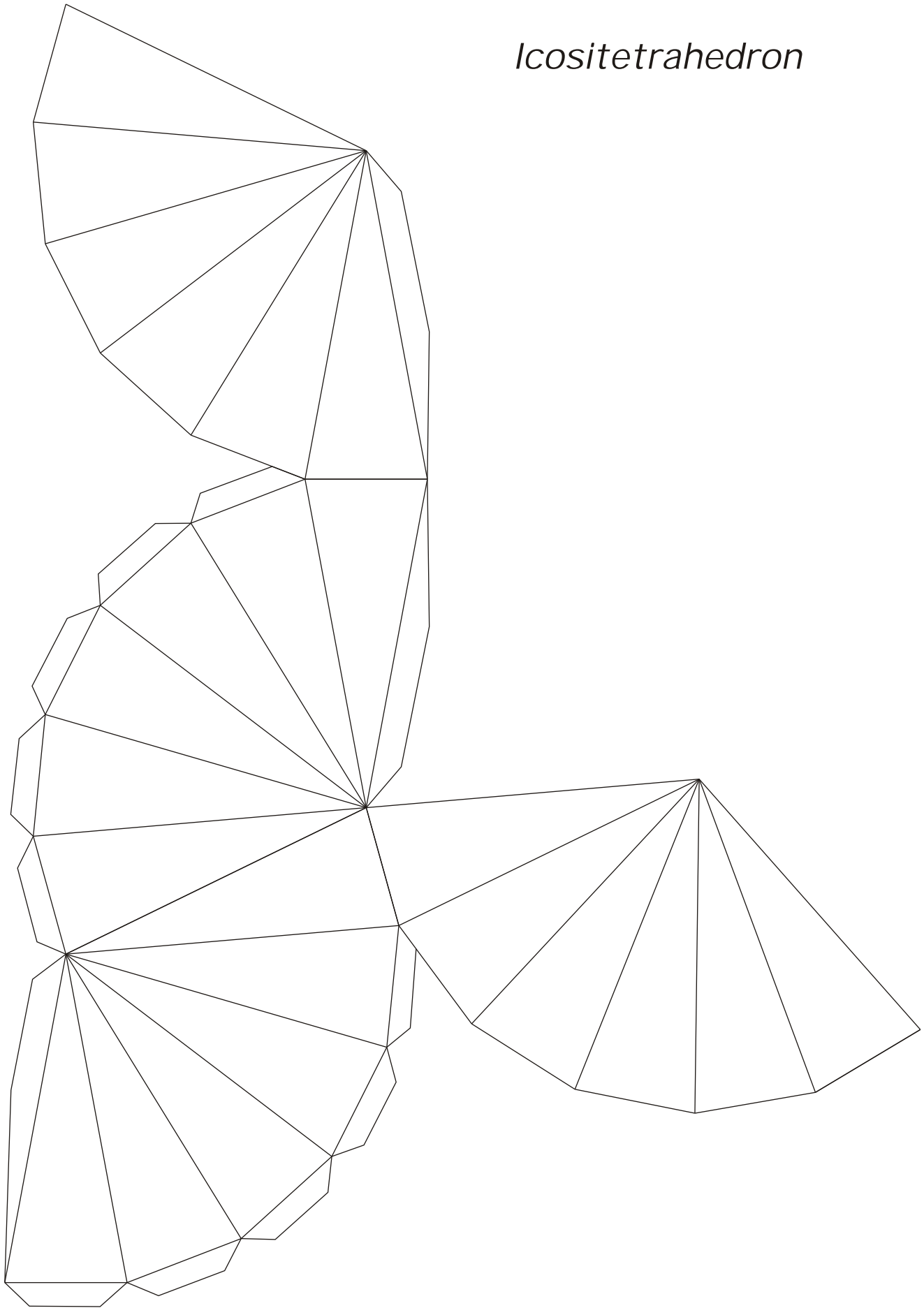

*Icosioctahedron*

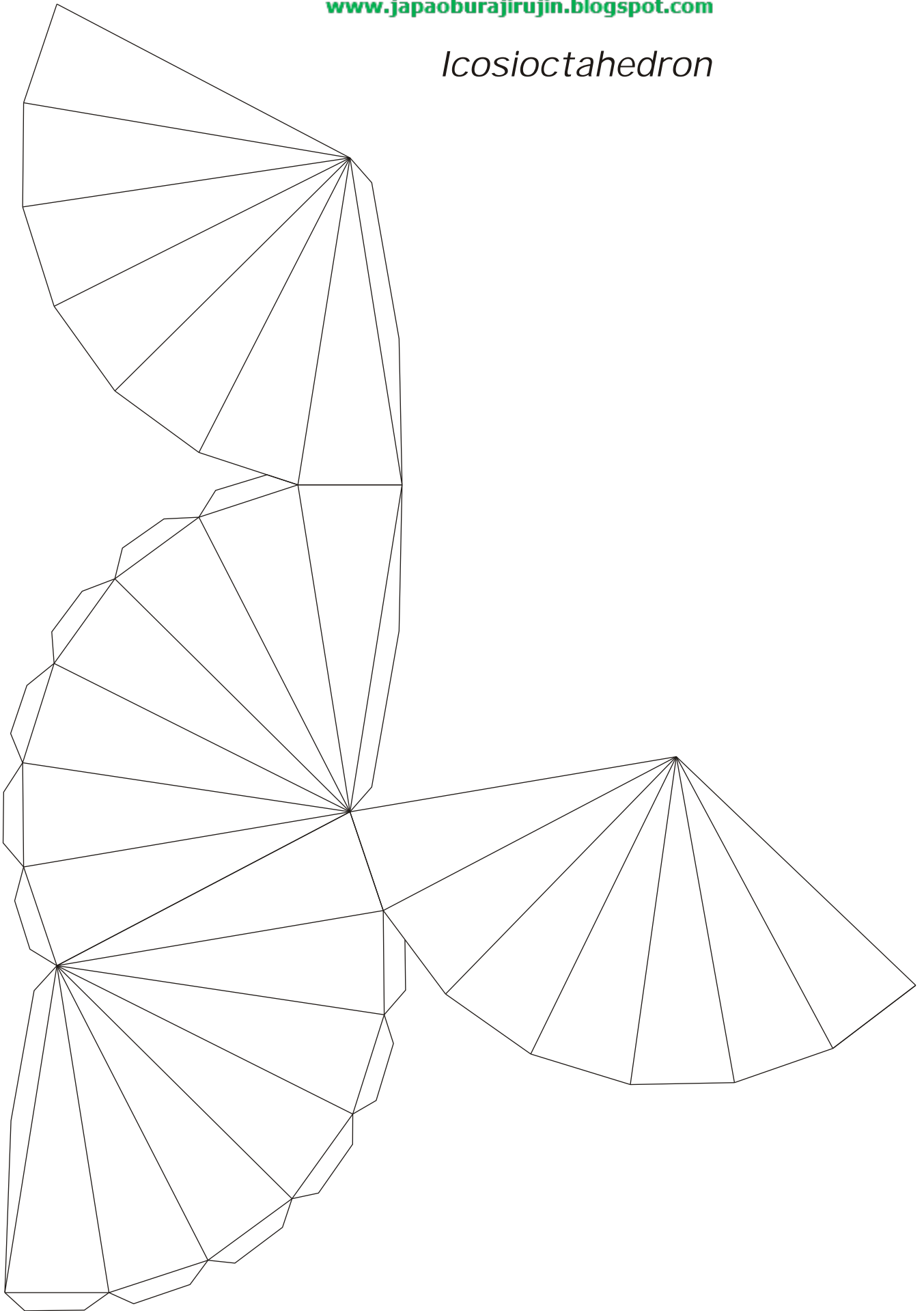

*Tricontidihedron*

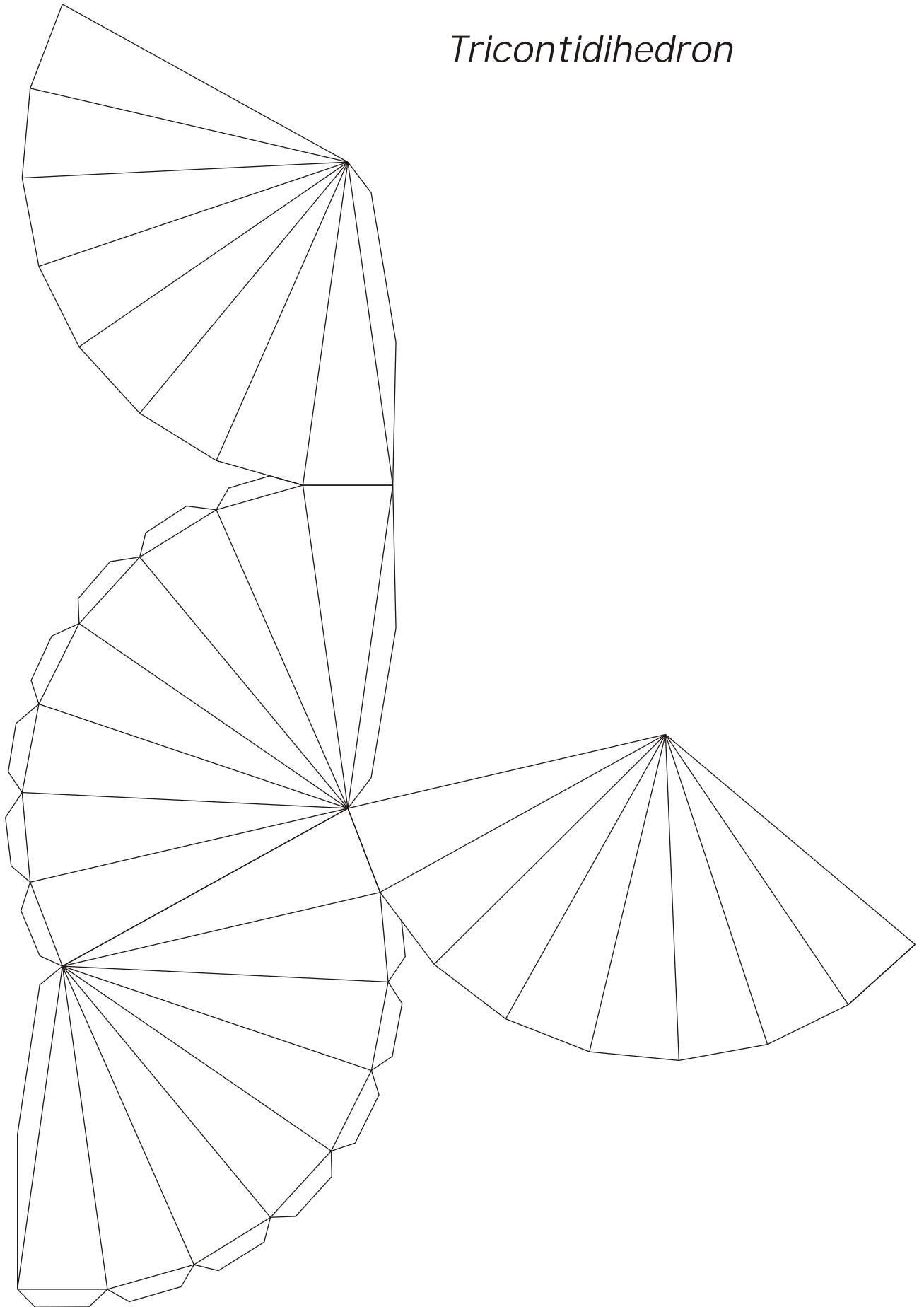



*Tricontihexahedron*

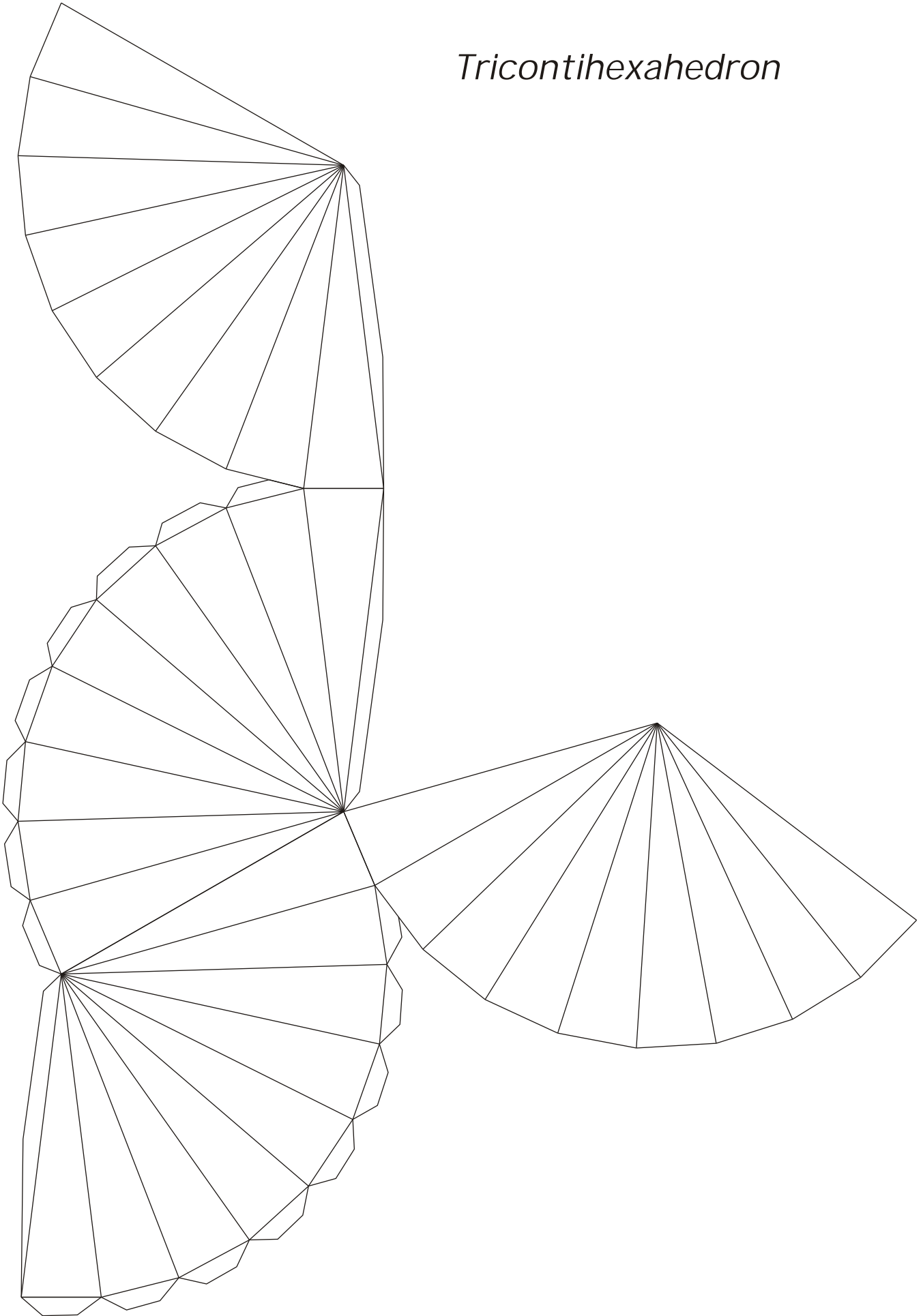

*Tetracontahedron*

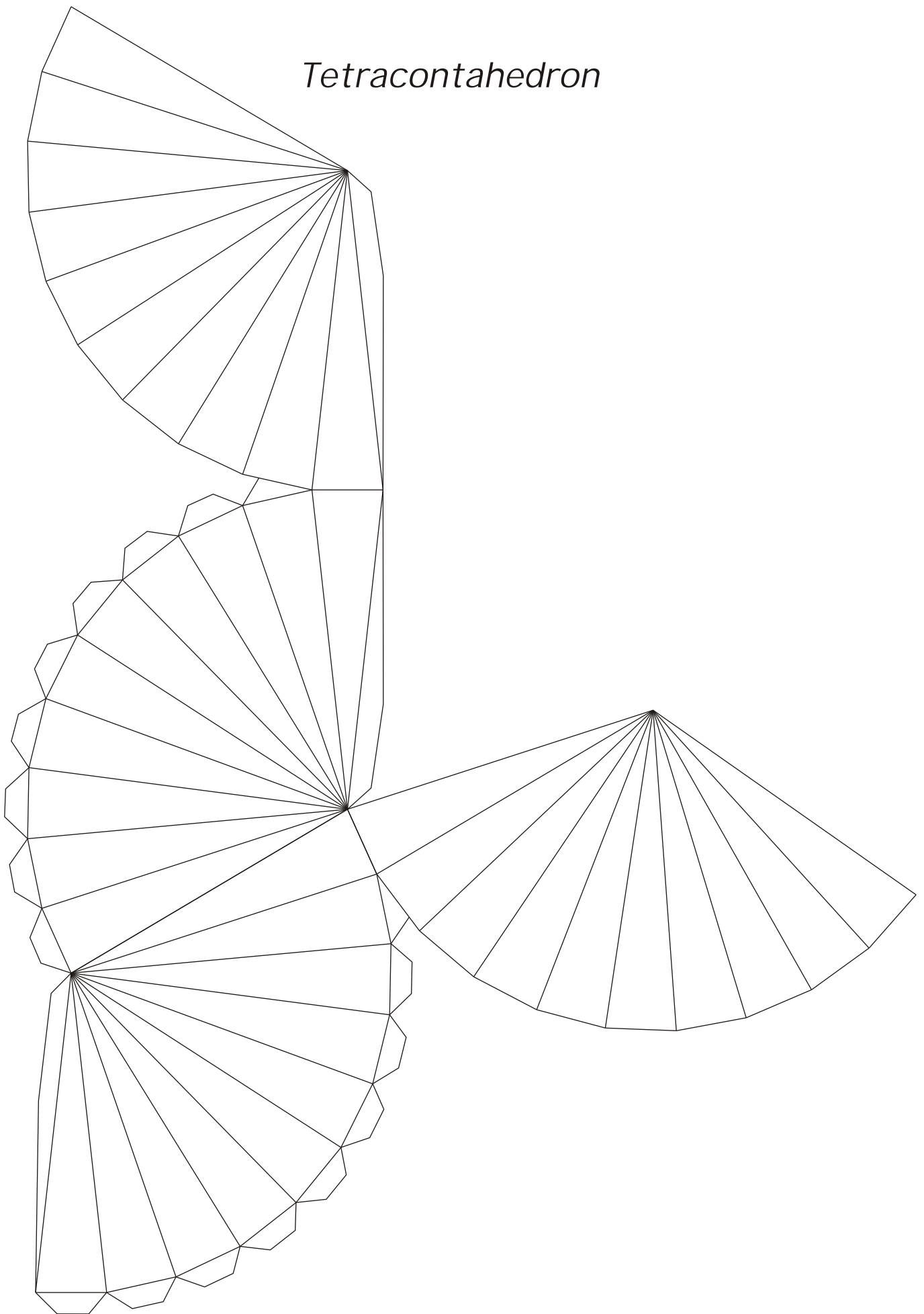

*Hecatohedron*

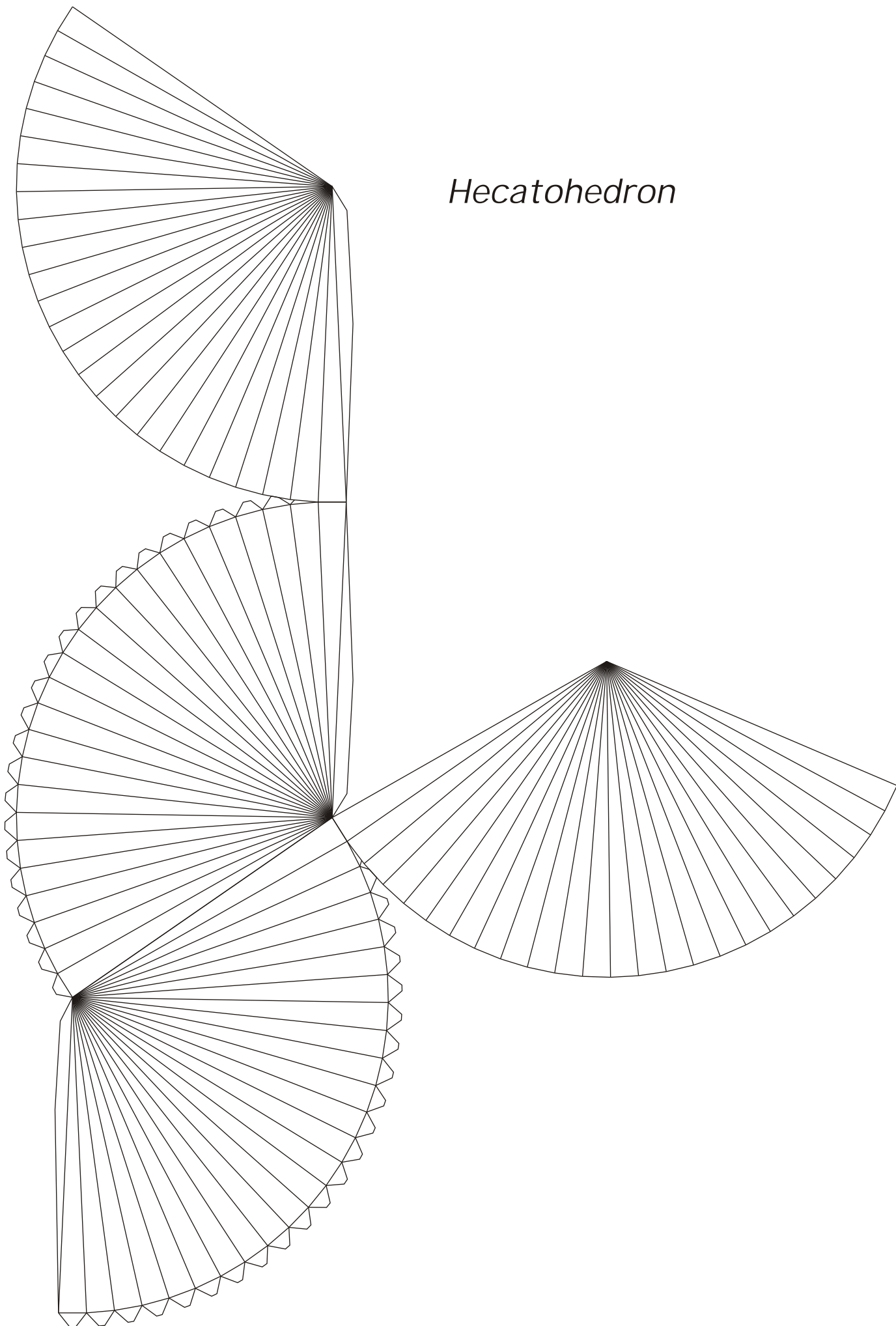

# Third Stallation of the Icosahedron

Fold the dotted lines forwards  
Fold the other lines backwards

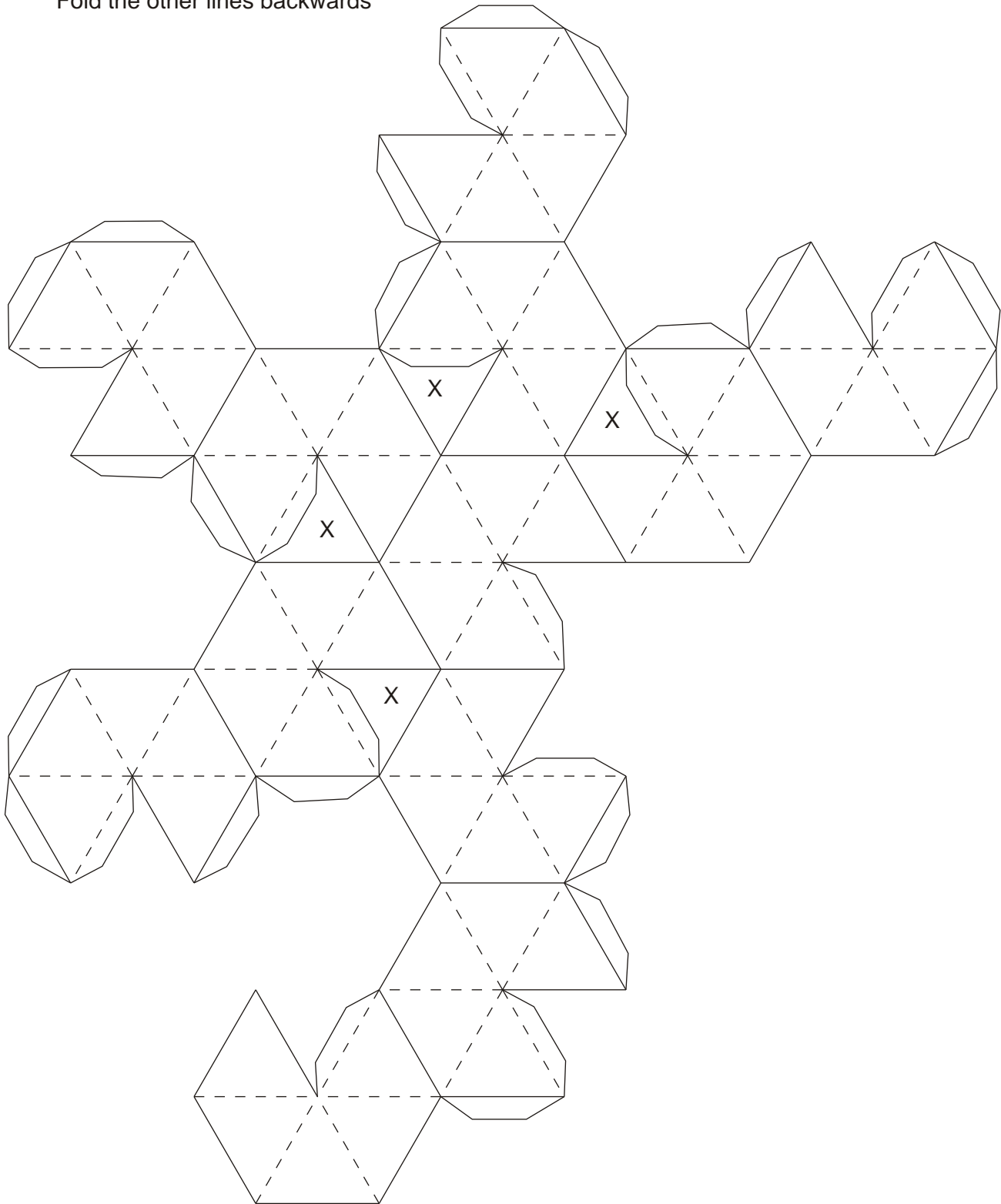

# Third Stellation of the Icosahedron

Fold the dotted lines forwards  
Fold the other lines backwards

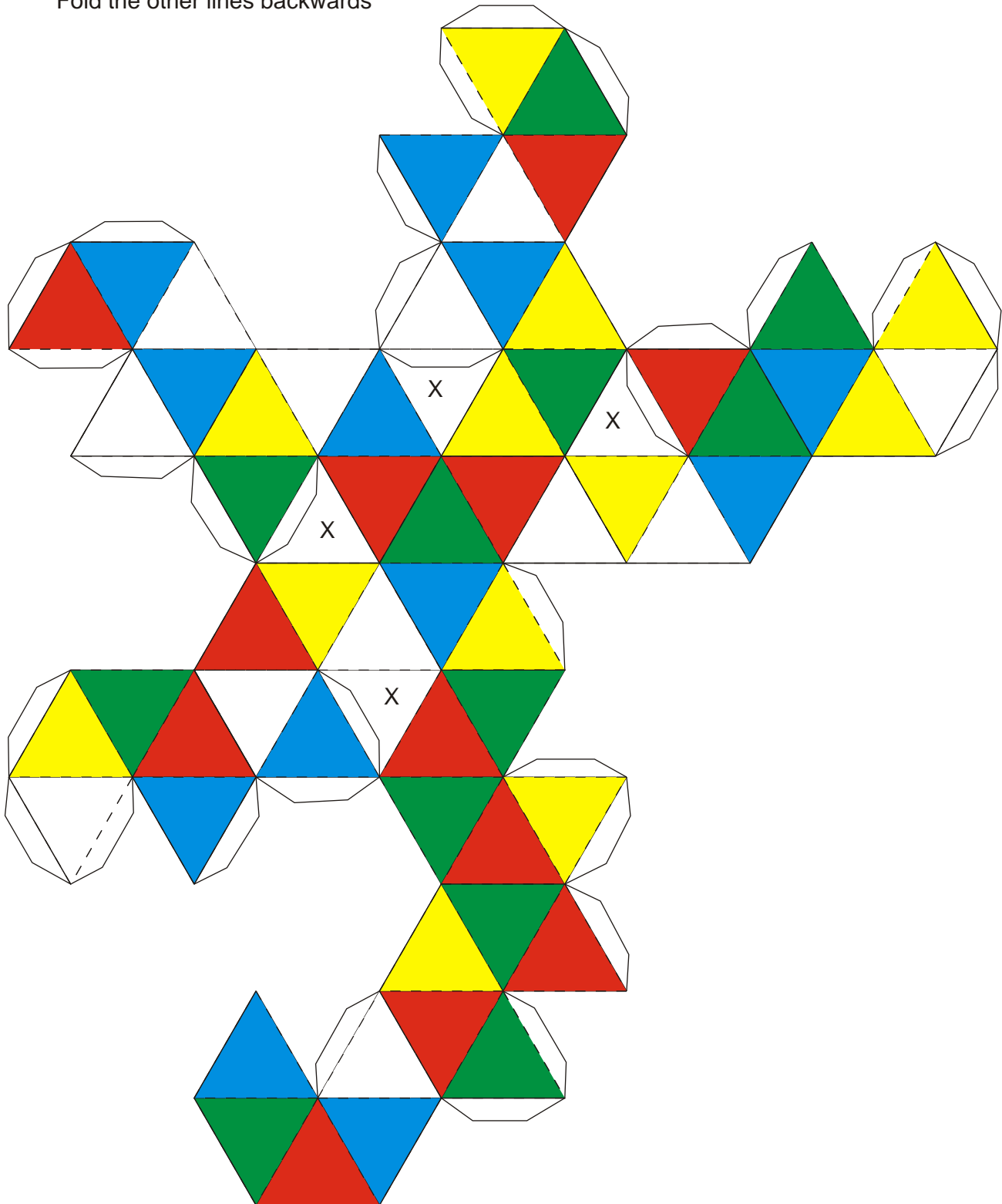

# Sixth Stallation of the Icosahedron

(small version)

Fold the dotted lines forwards

Fold the other lines backwards

First glue part A

Glue the parts A-M on A

Part A:

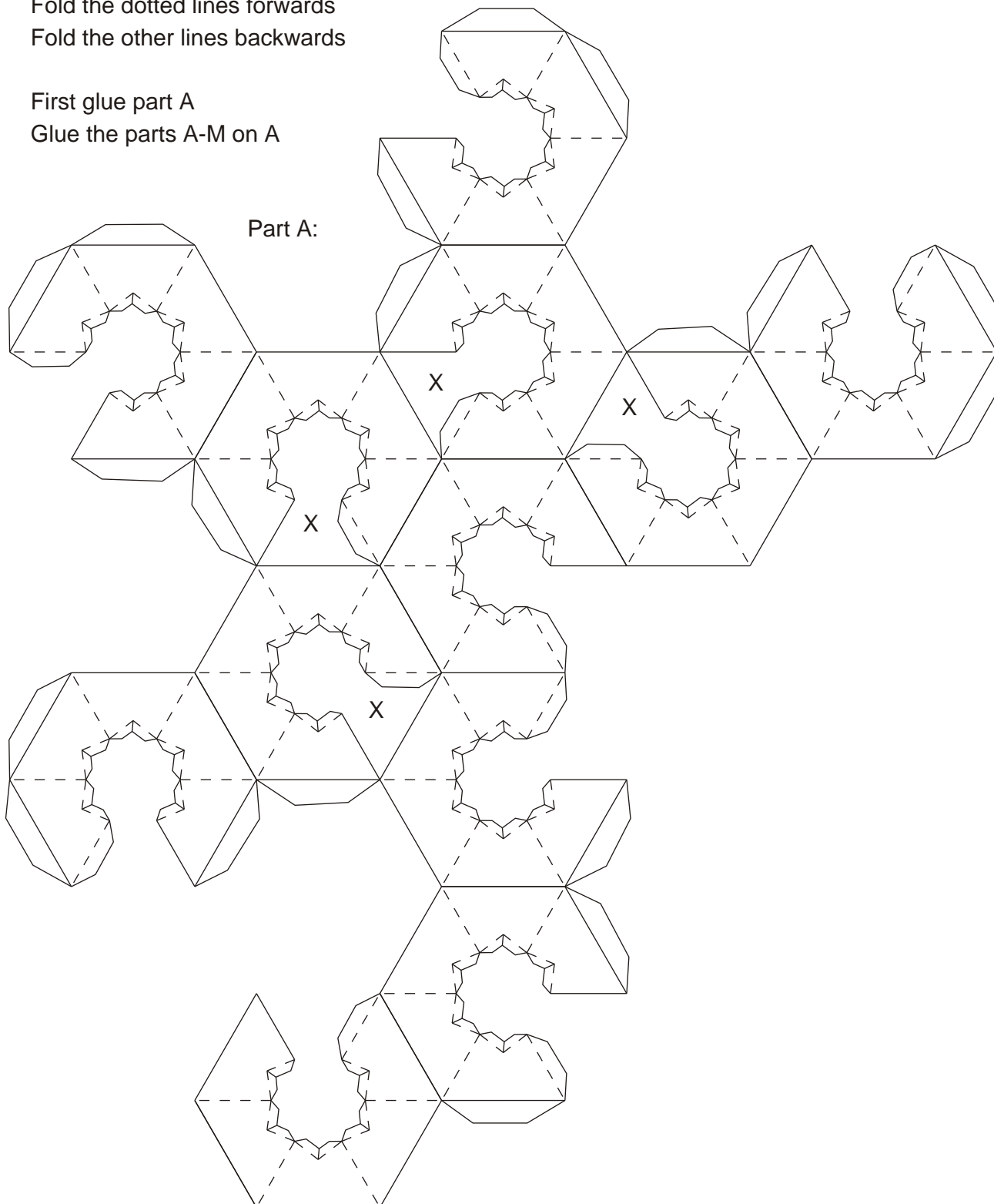

Parts B-M

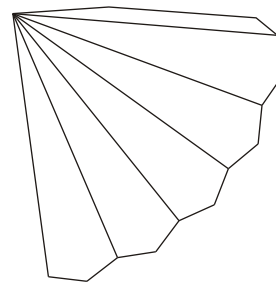
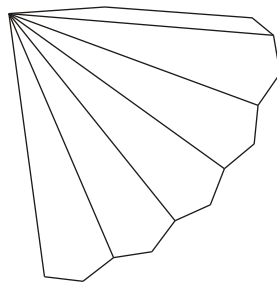
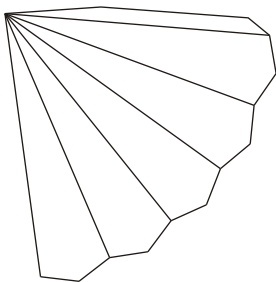
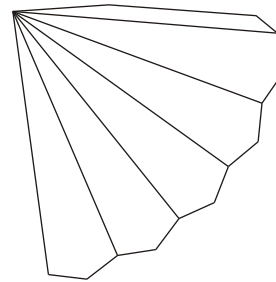
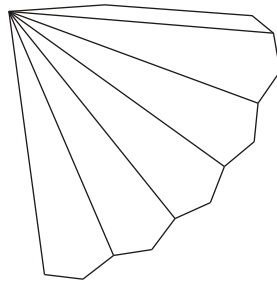
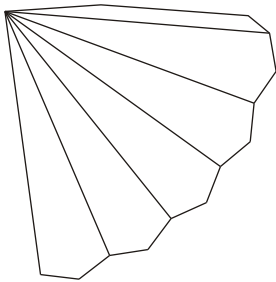
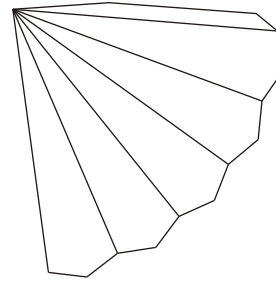
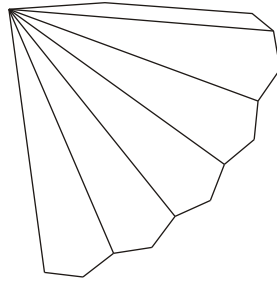
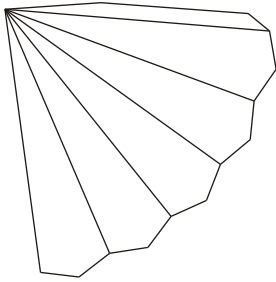
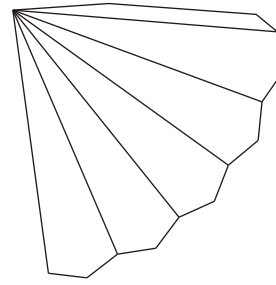
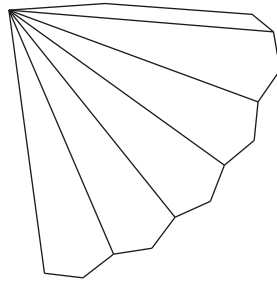
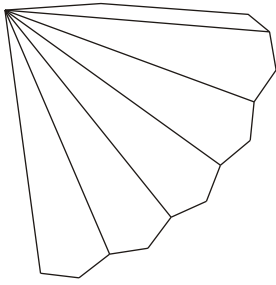

# Sixth Stellation of the Icosahedron (large version)

First glue the parts A until F

Glue the 12 other parts on the ABCDEF

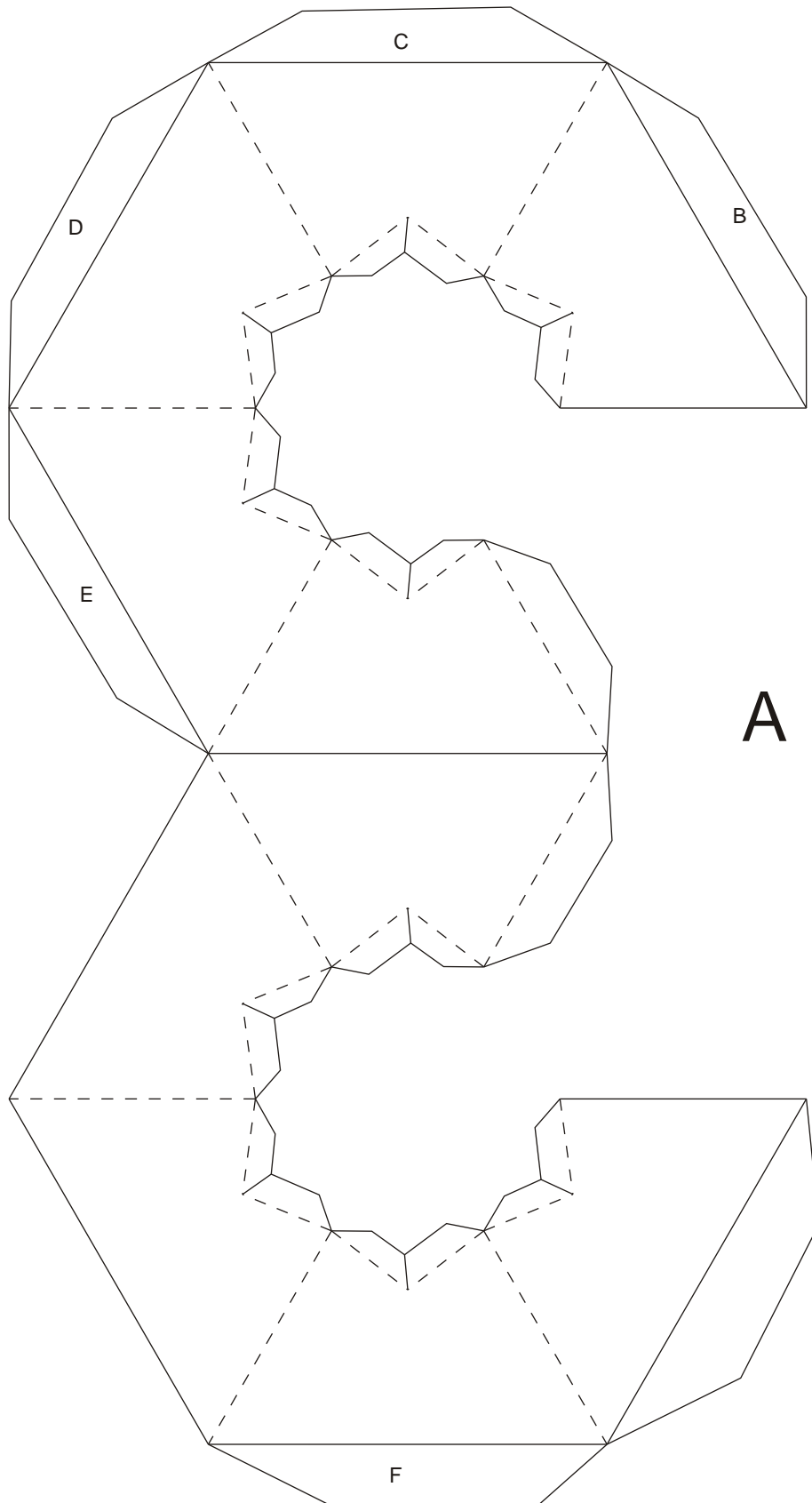



Sixth Stellation of the Icosahedron  
(large version)

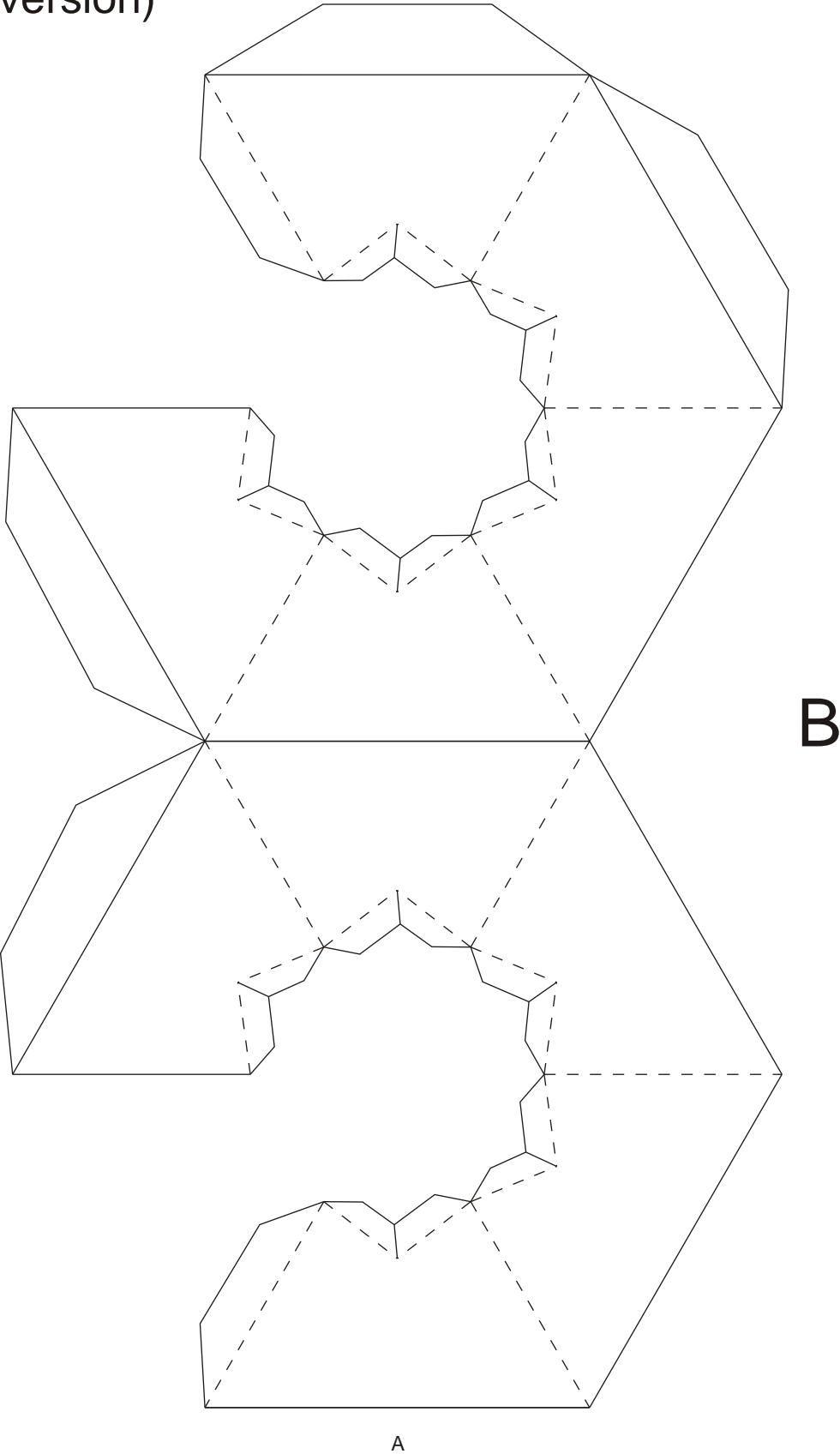

Sixth Stellation of the Icosahedron  
(large version)

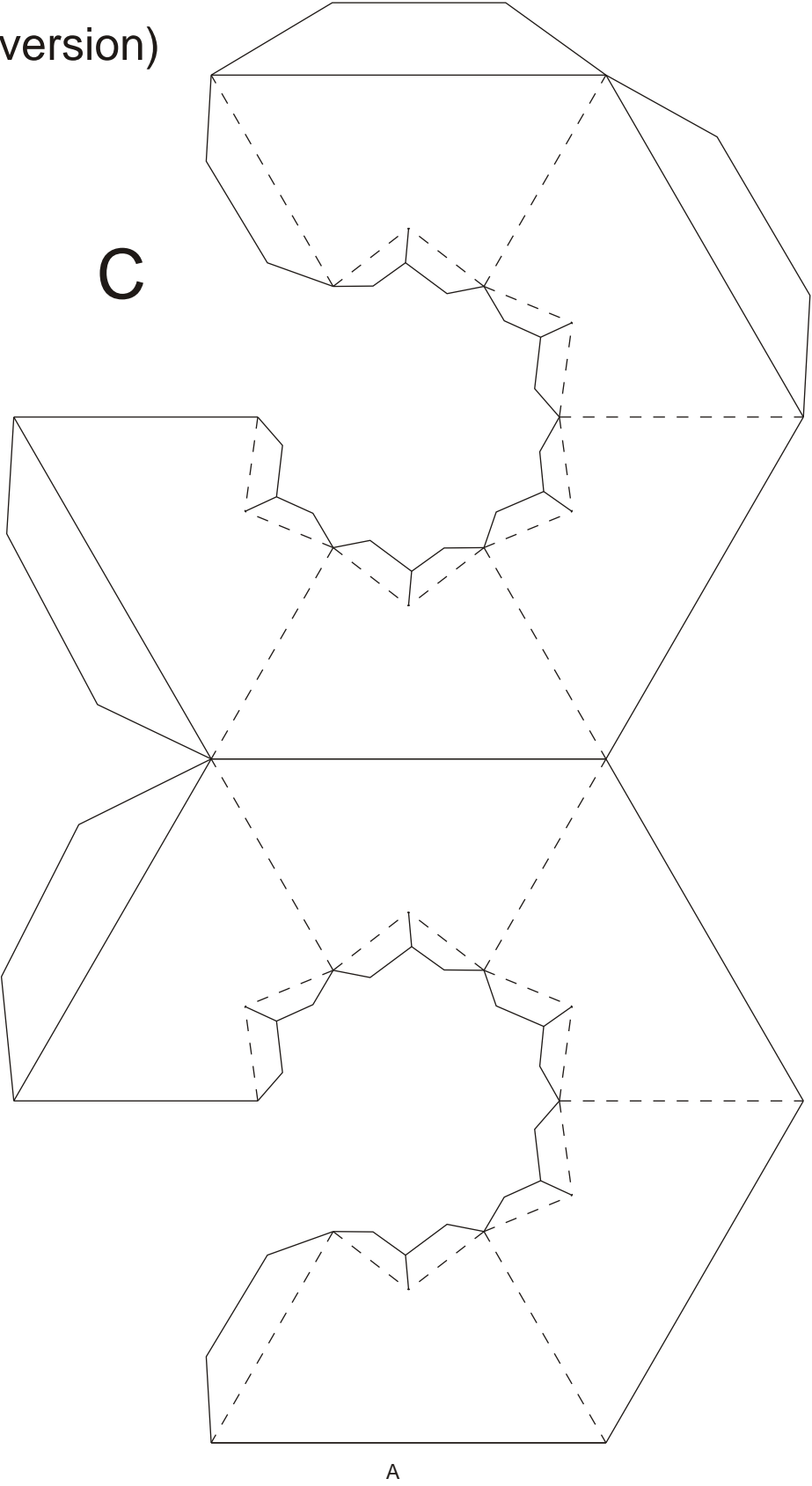

Sixth Stellation of the Icosahedron  
(large version)

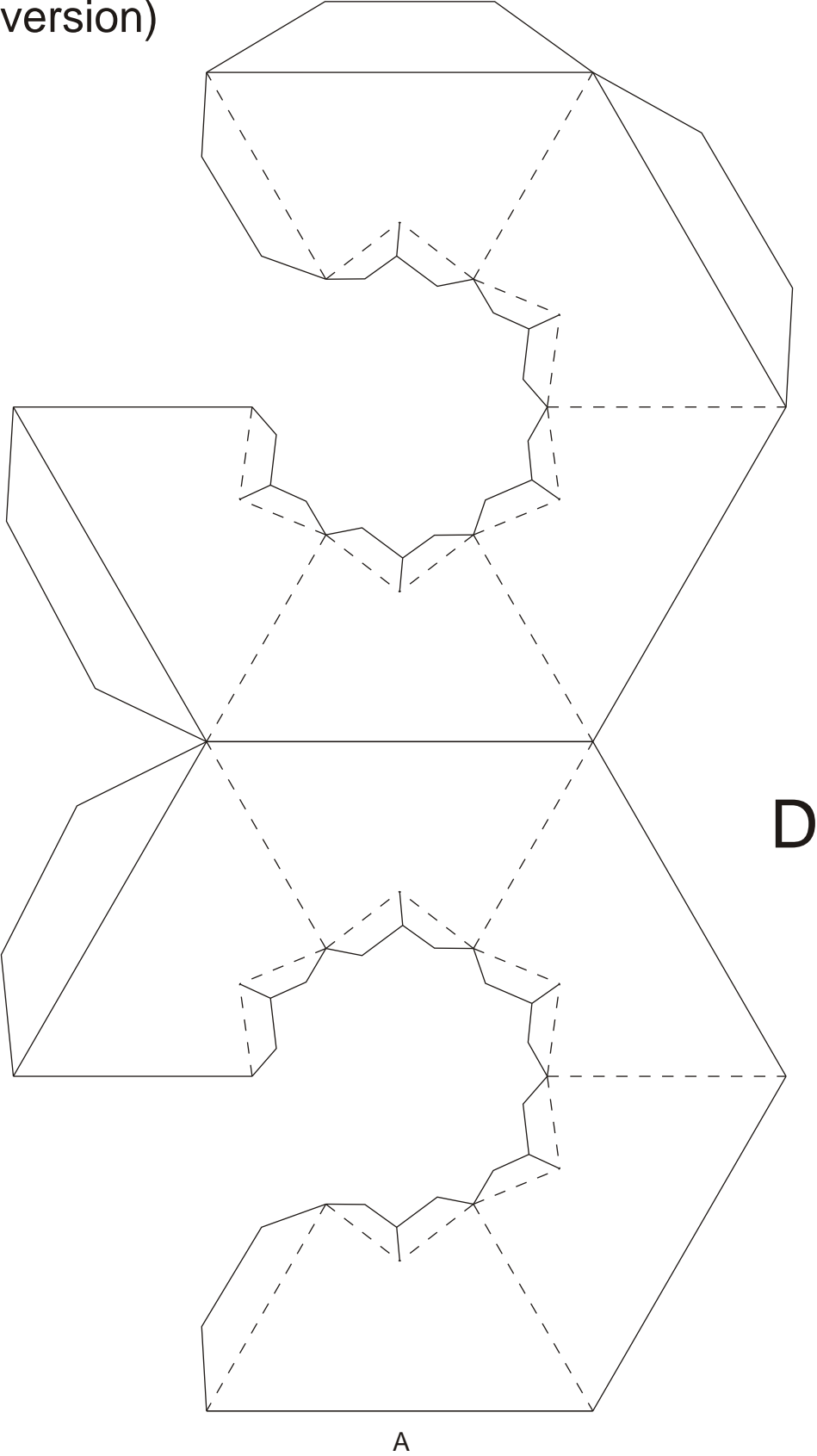

Sixth Stellation of the Icosahedron  
(large version)

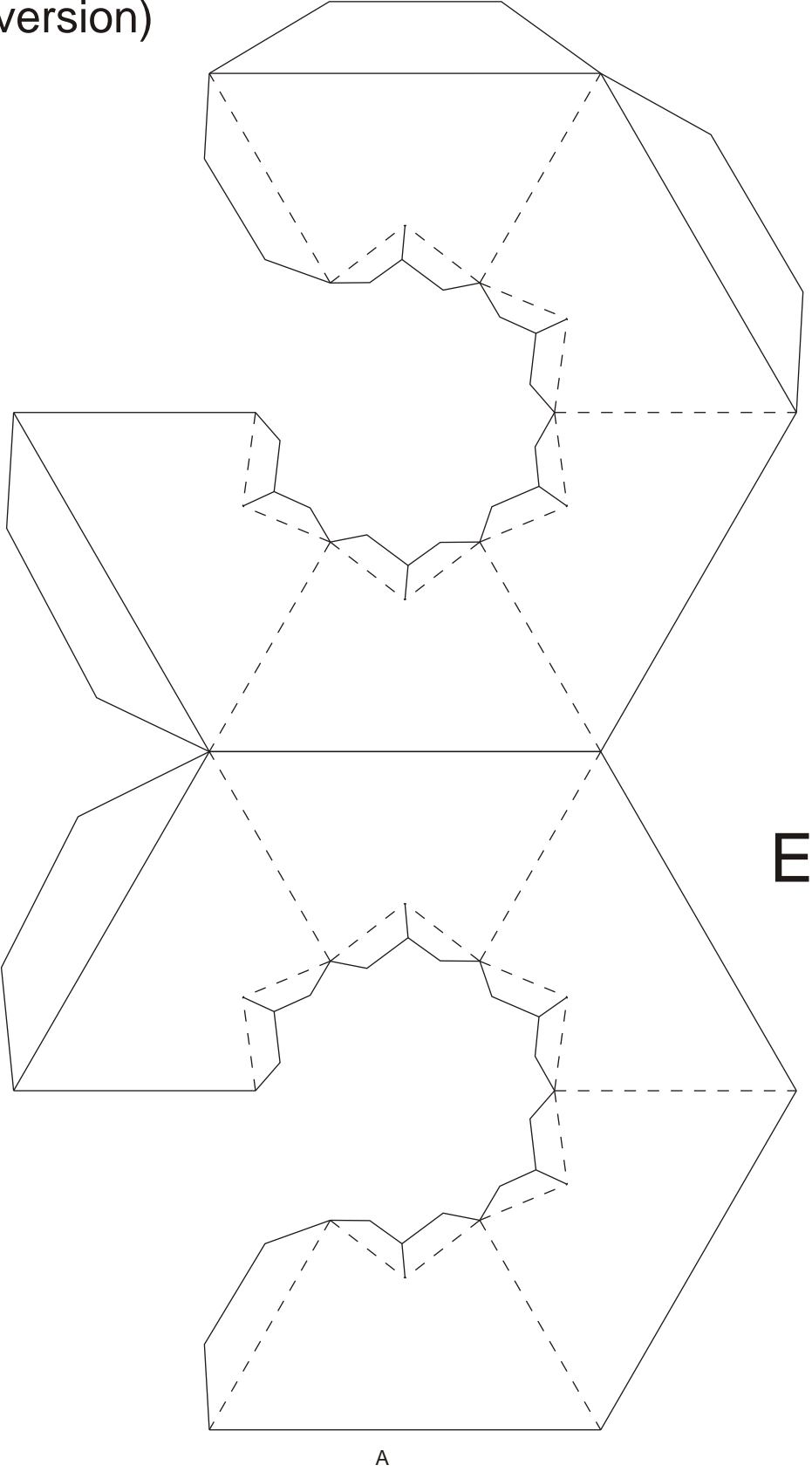

# Sixth Stellation of the Icosahedron (large version)

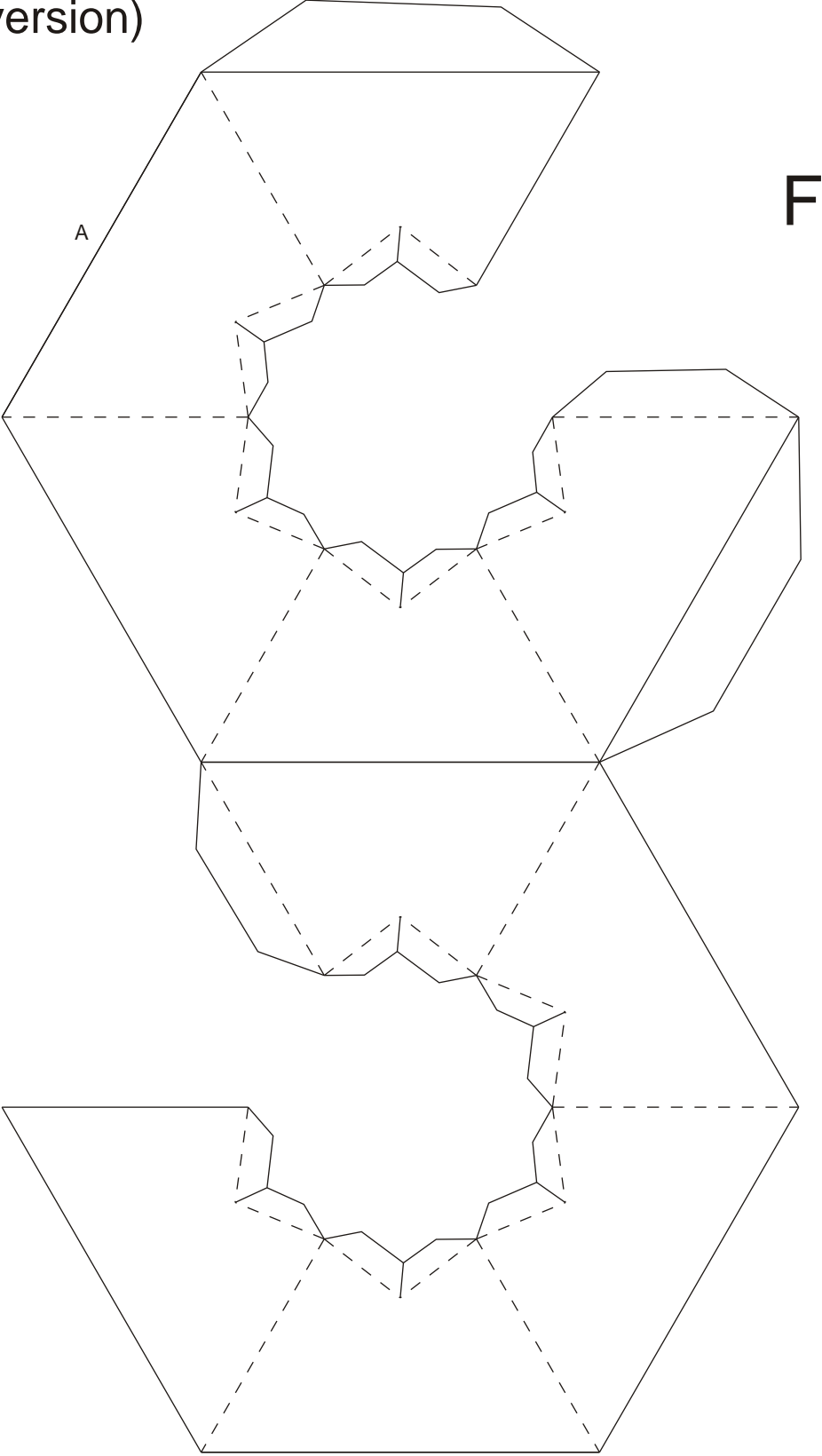

Sixth Stallation of the Icosahedron  
(large)

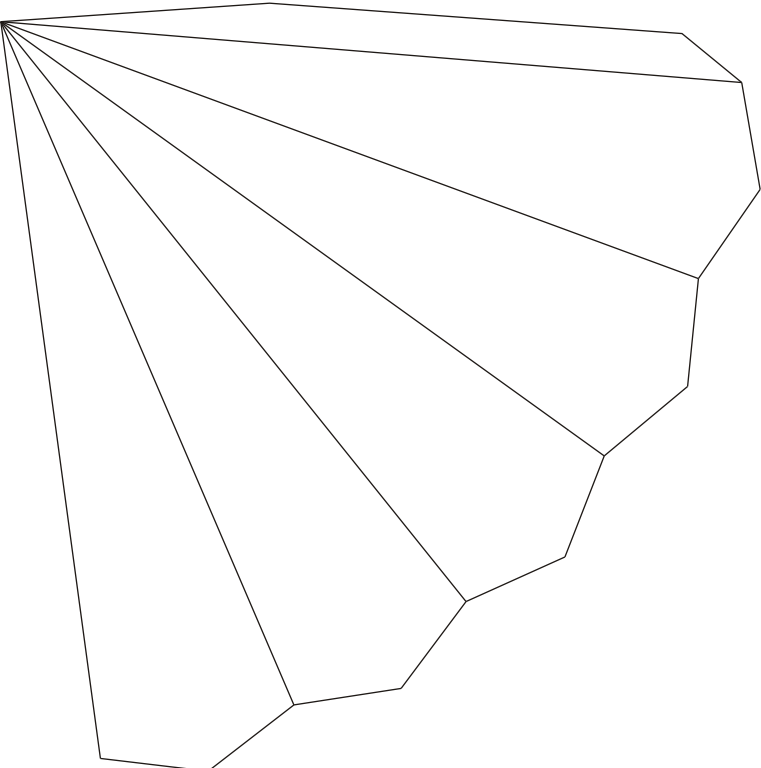
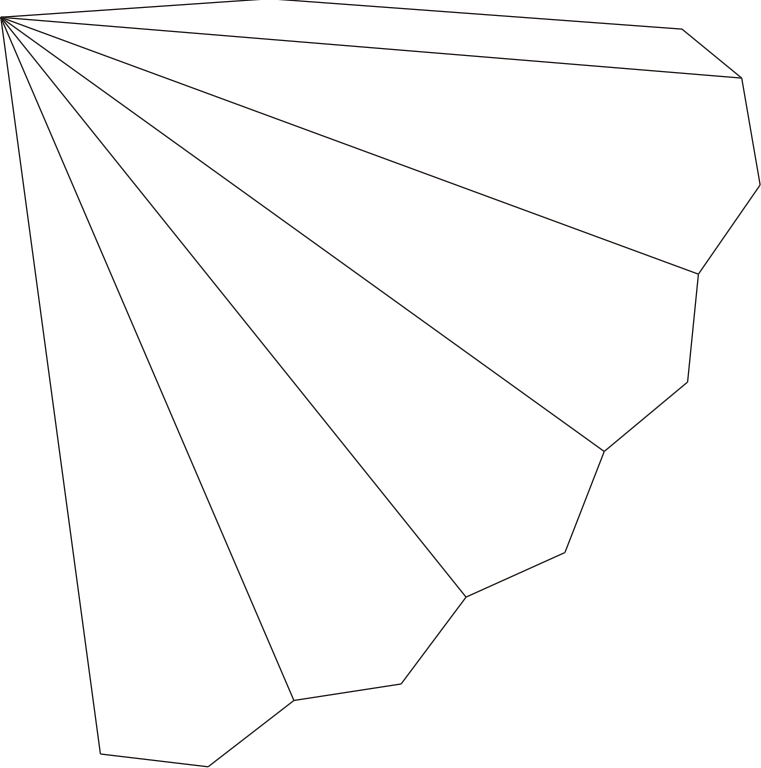

Sixth Stallation of the Icosahedron  
(large)

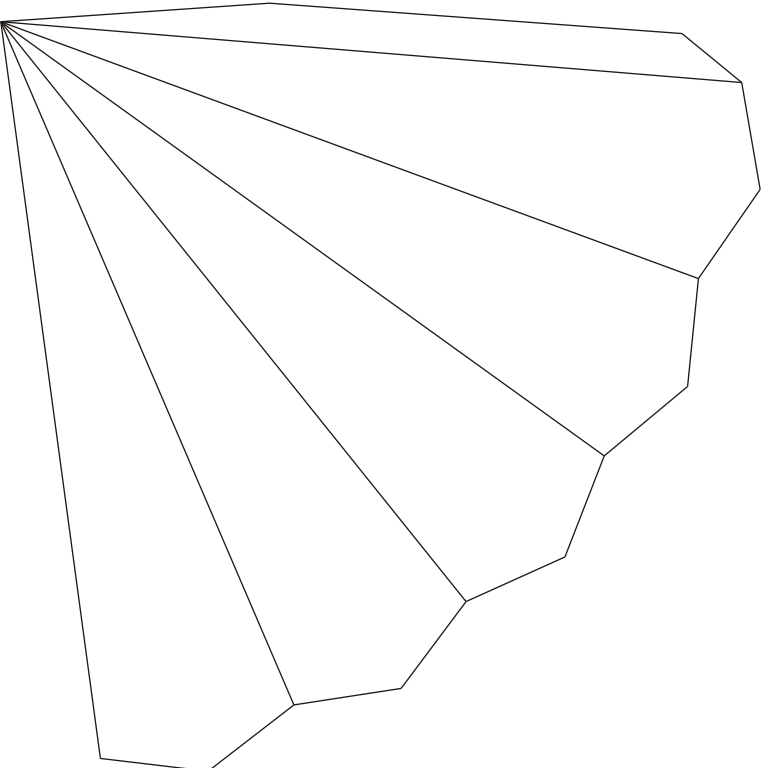
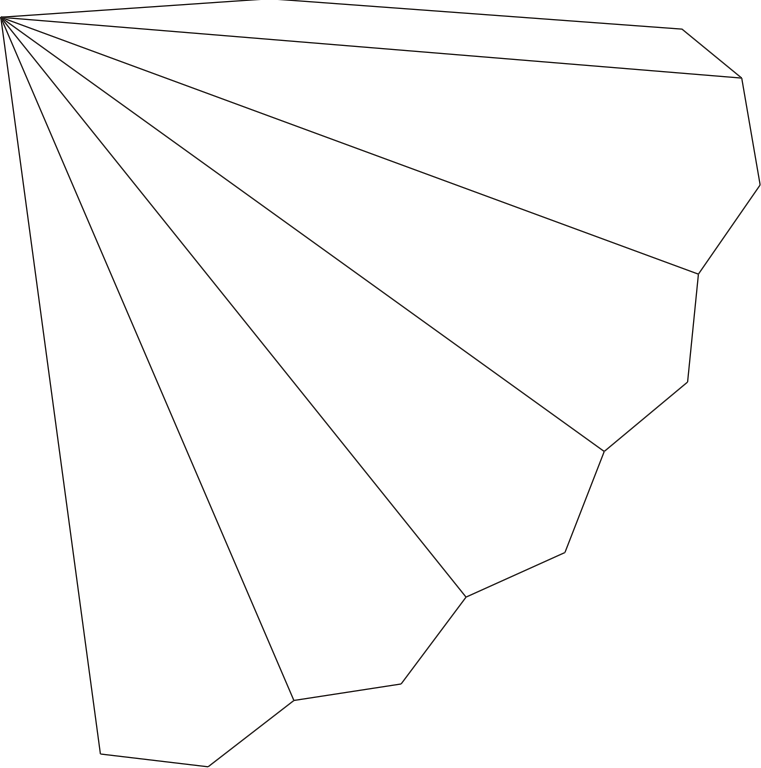

Sixth Stallation of the Icosahedron  
(large)

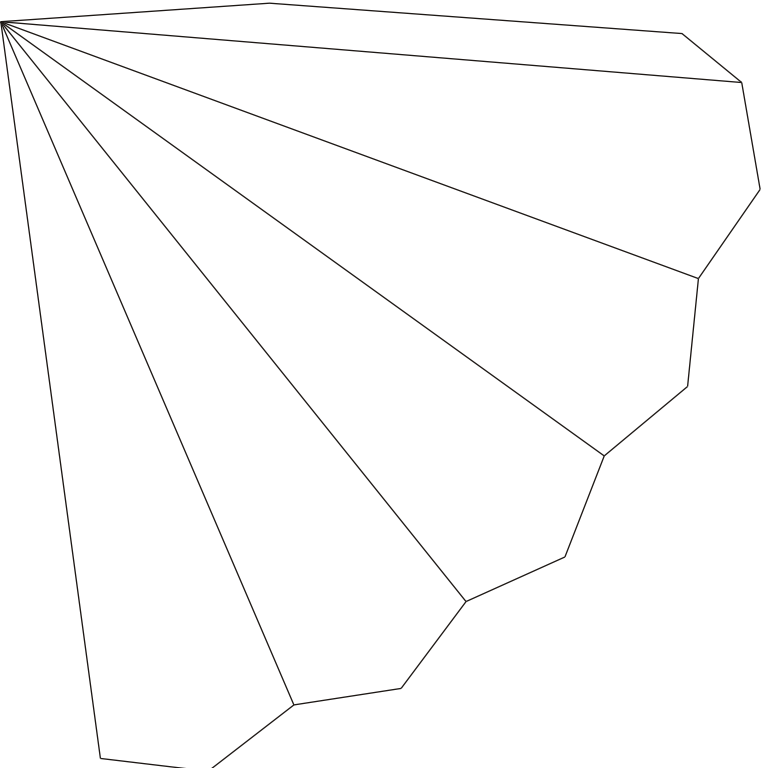
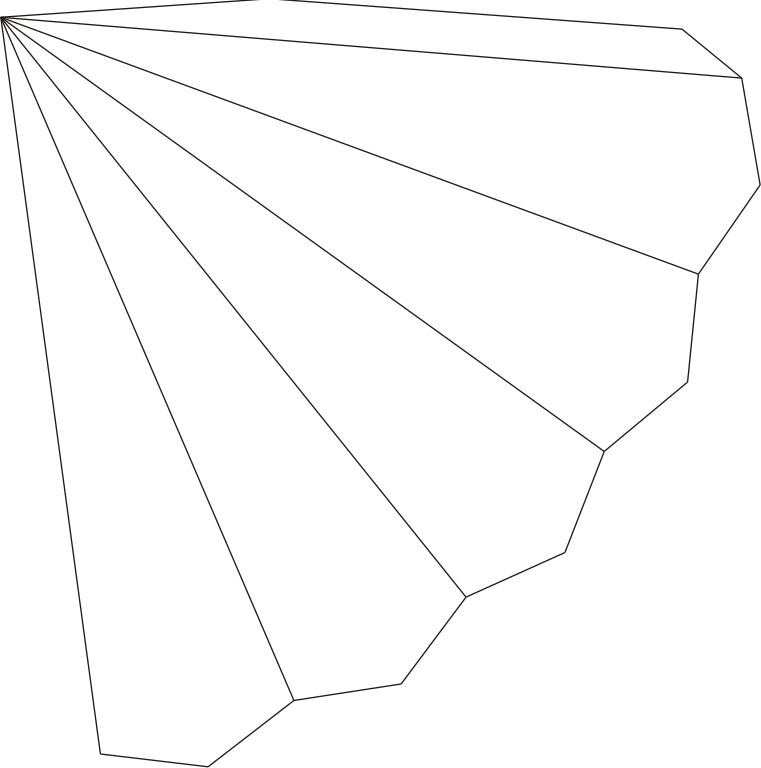



# Sixth Stallation of the Icosahedron

(large)

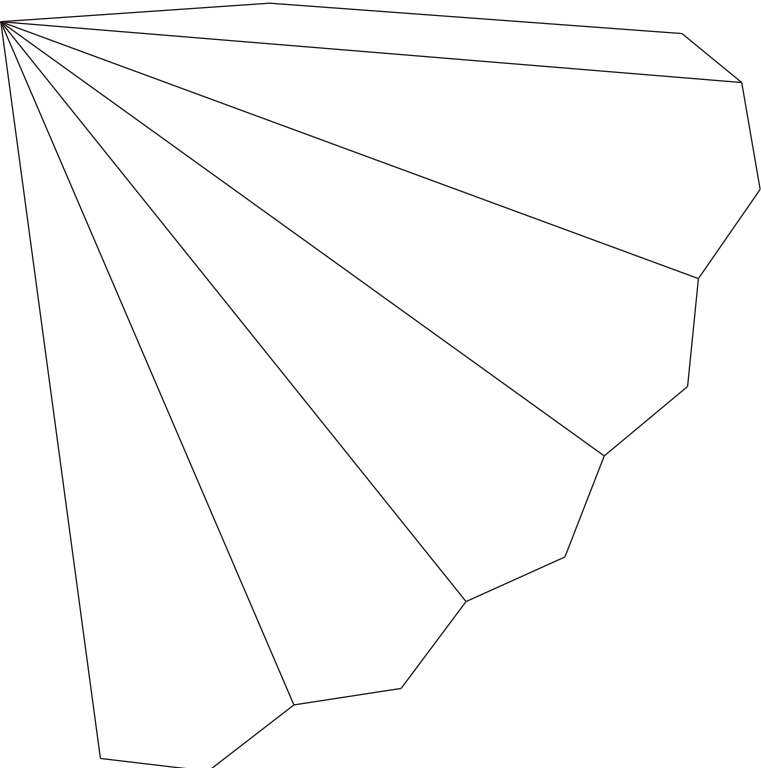
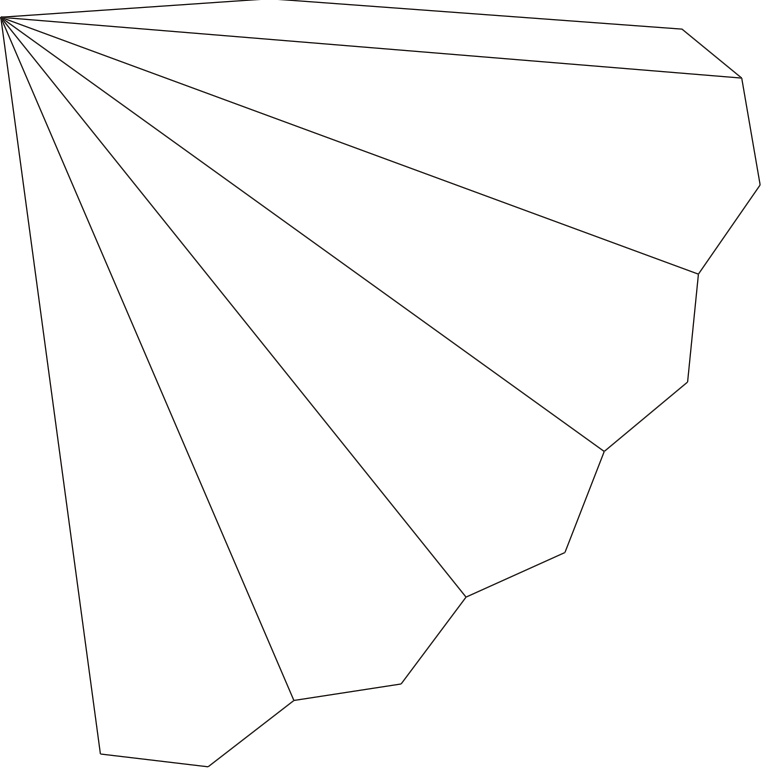

Sixth Stallation of the Icosahedron  
(large)

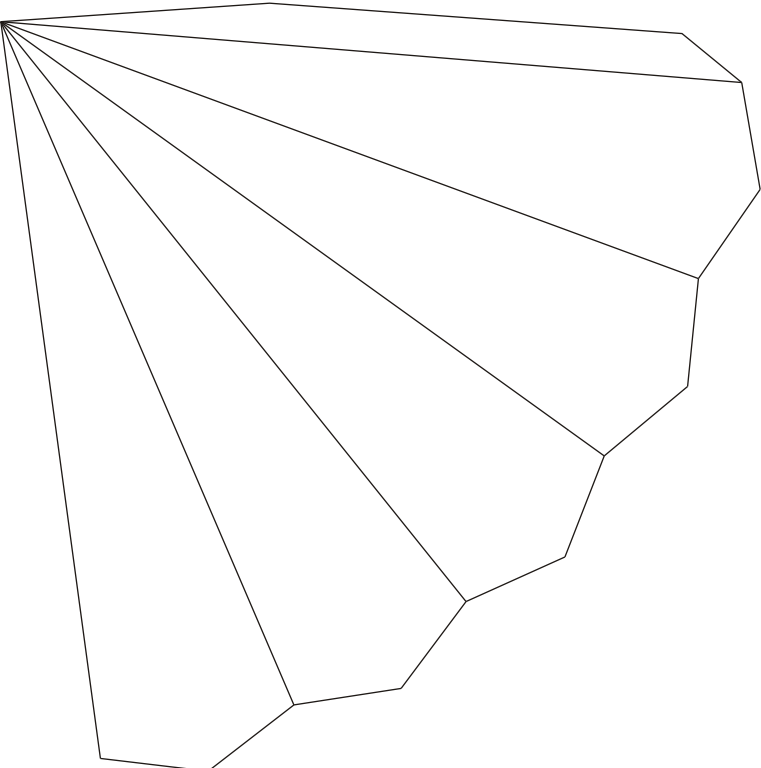
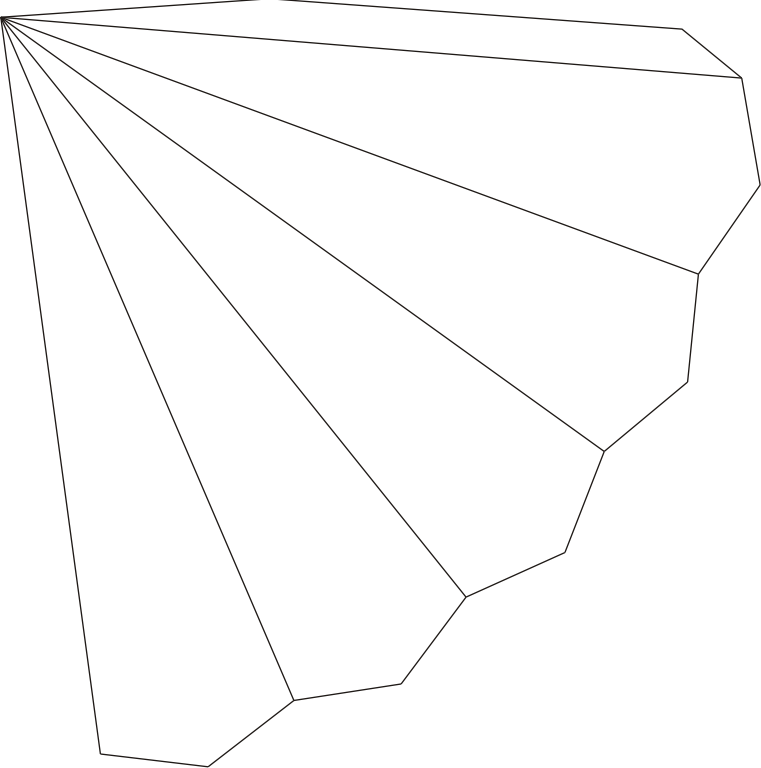

Sixth Stallation of the Icosahedron  
(large)

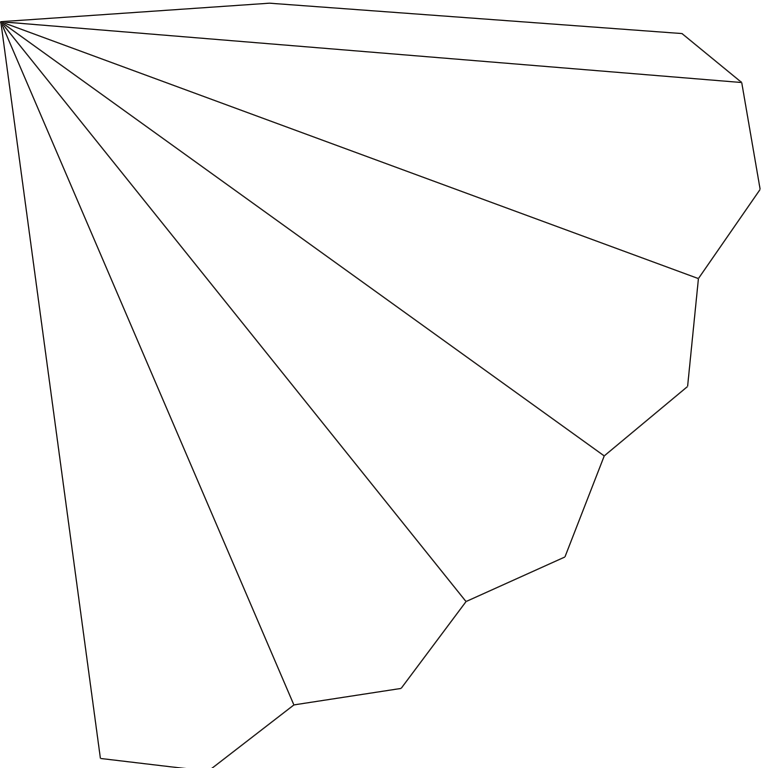
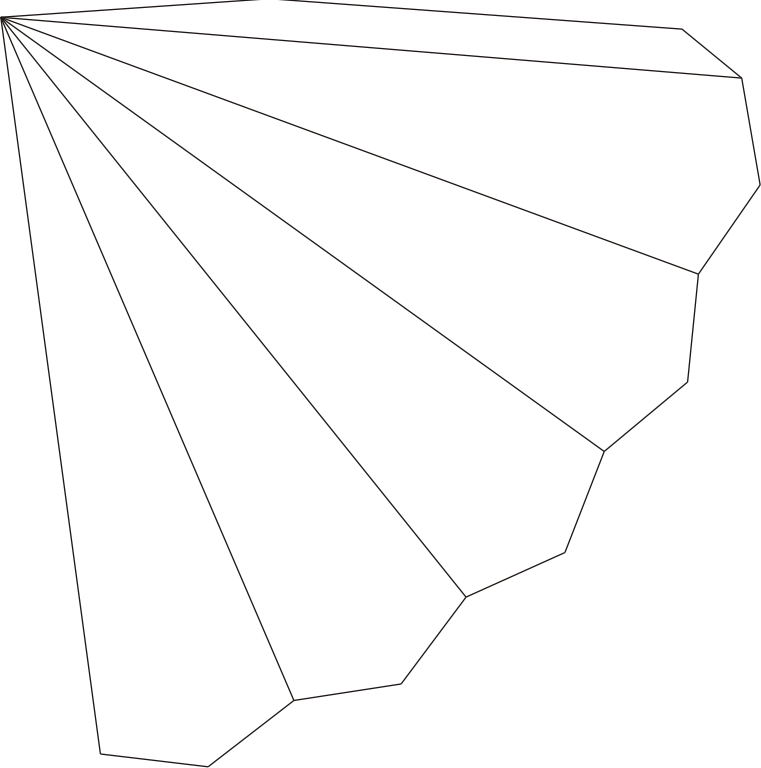

# Seventh Stellation of the Icosahedron

A

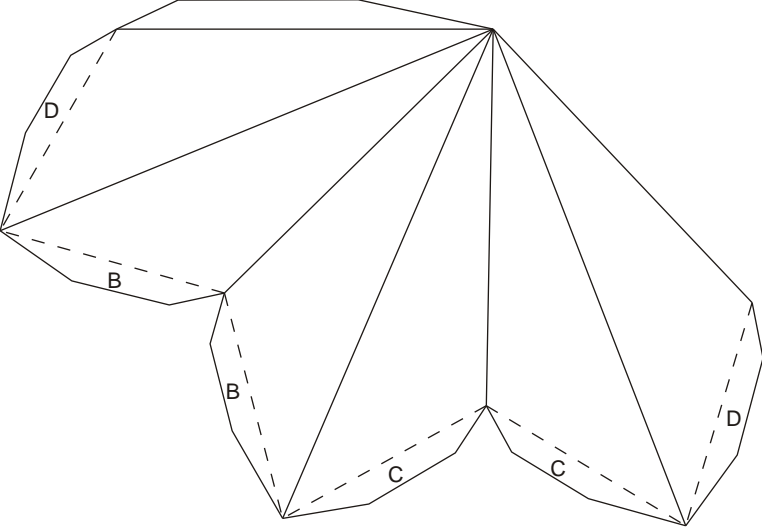

B

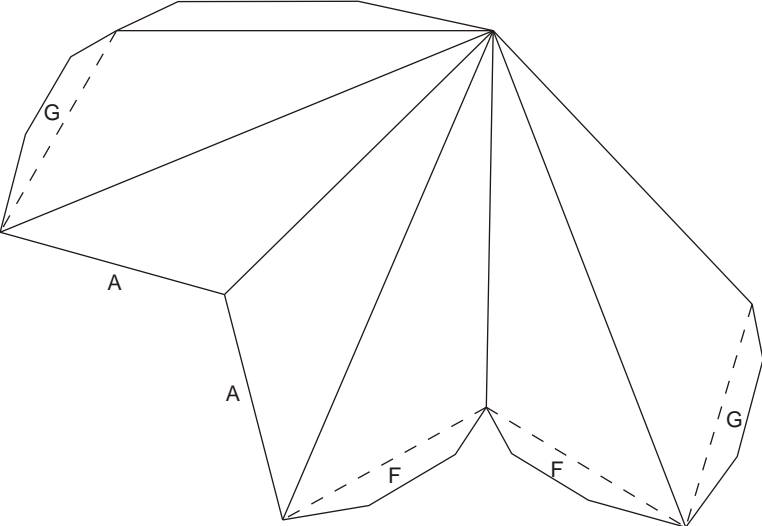

C

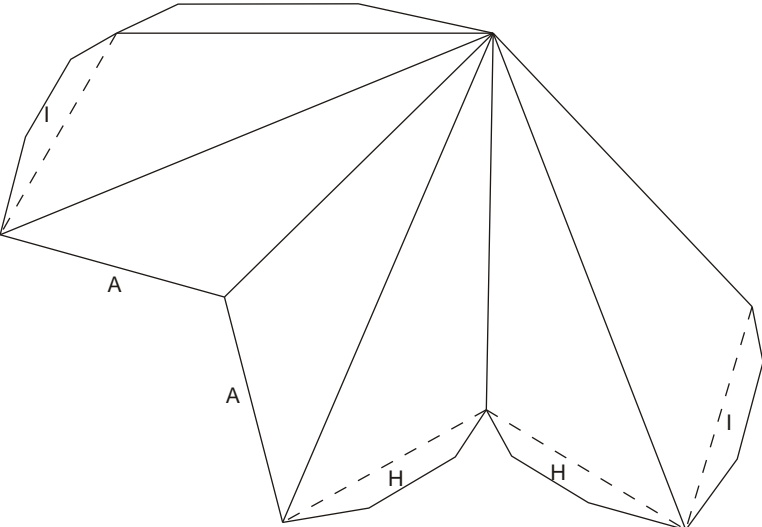

# Seventh Stellation of the Icosahedron

D

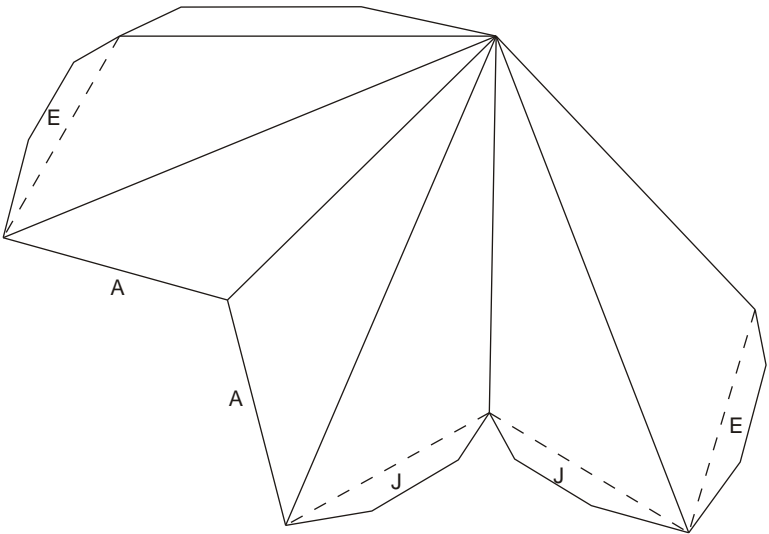

E

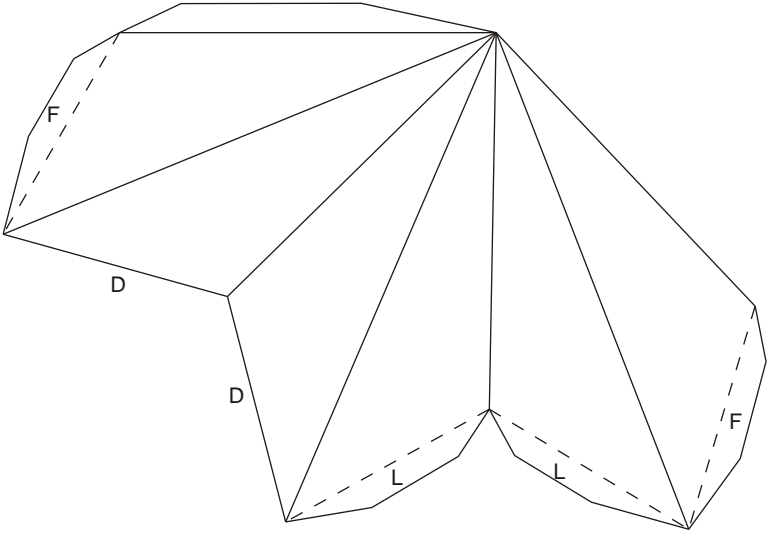

F

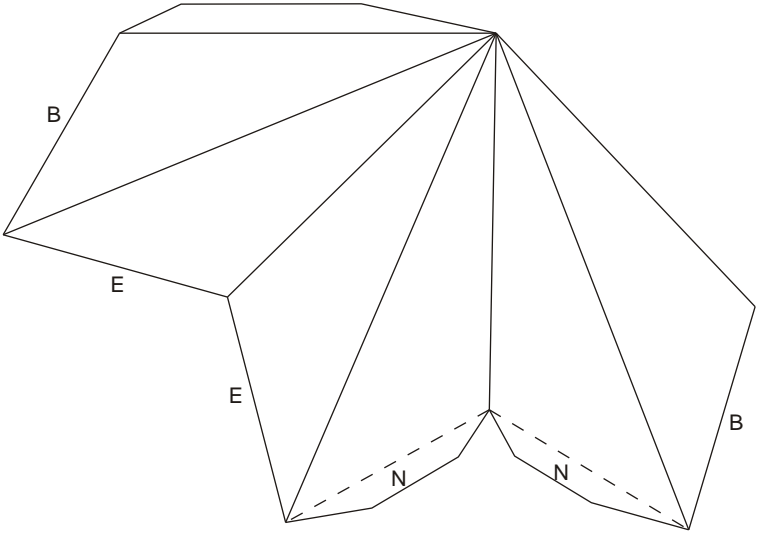

# Seventh Stellation of the Icosahedron

**G**

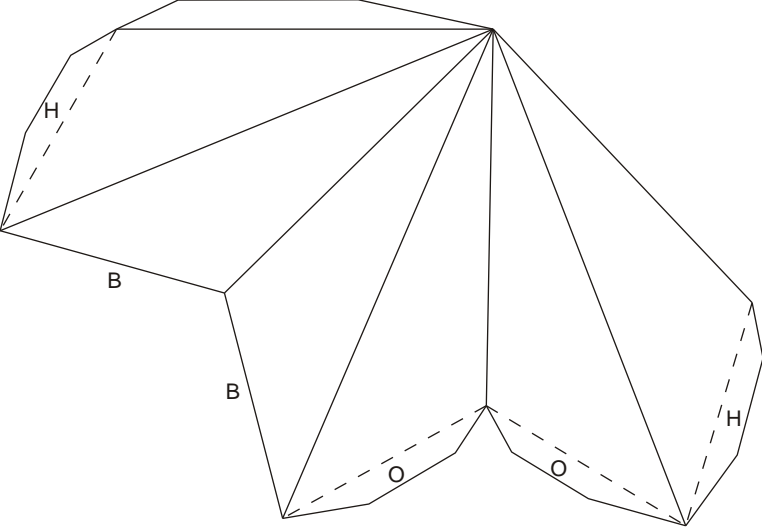

**H**

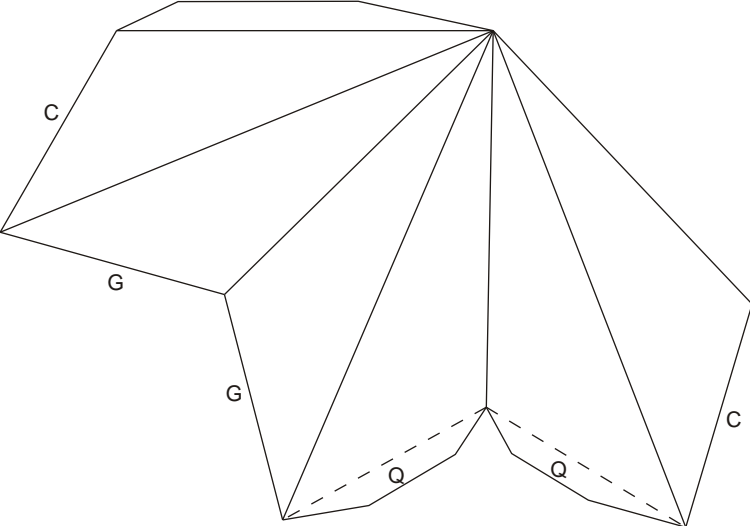

**I**

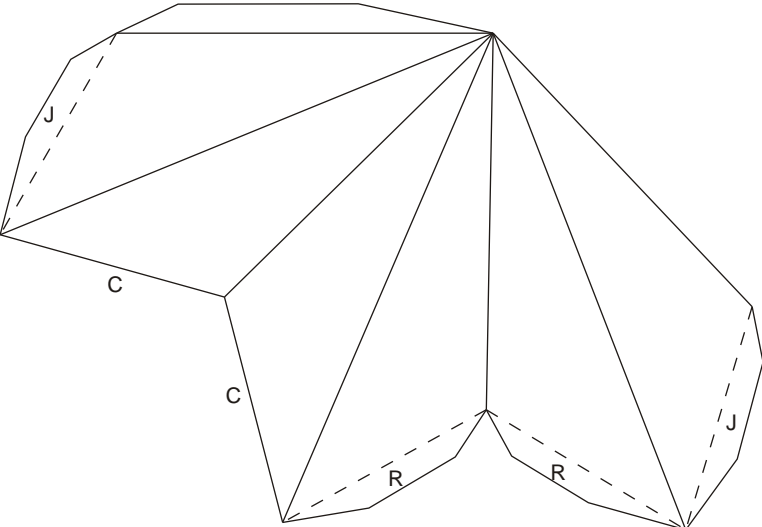

# Seventh Stellation of the Icosahedron

J

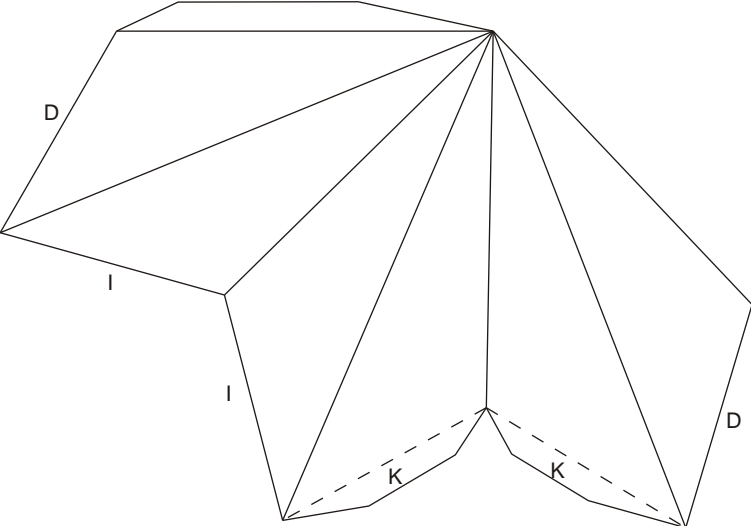

K

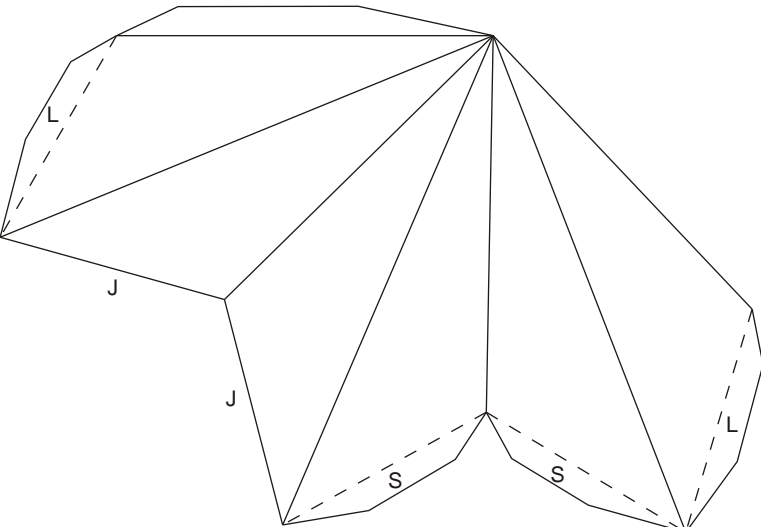

L

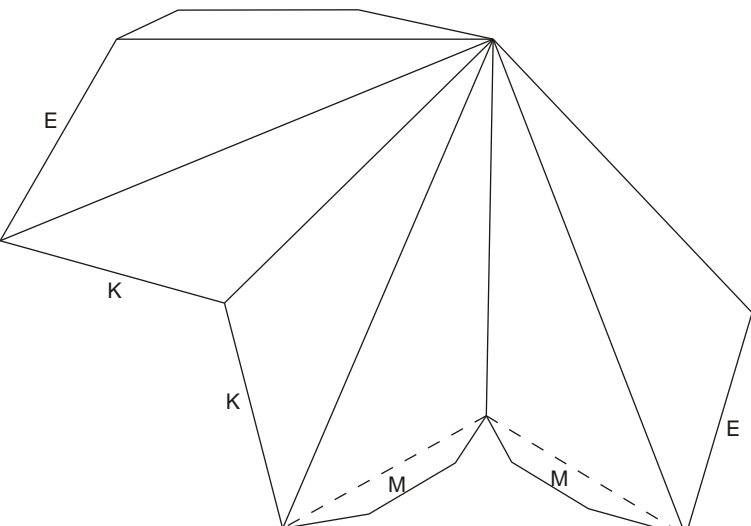

# Seventh Stellation of the Icosahedron

M

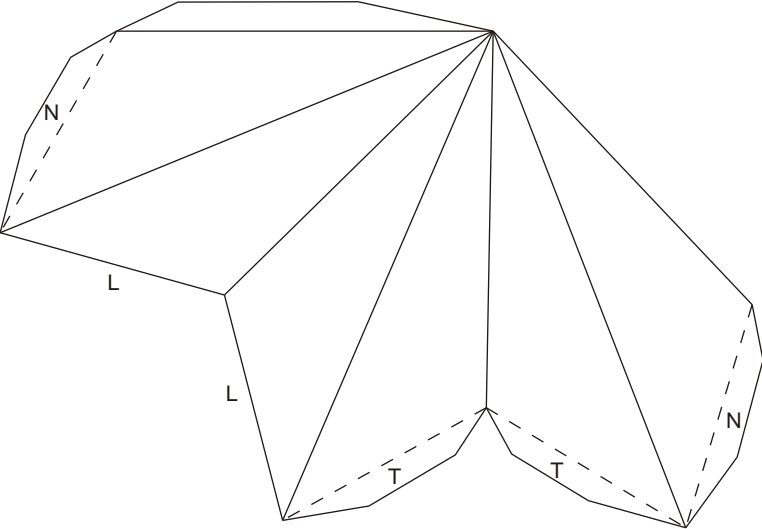

N

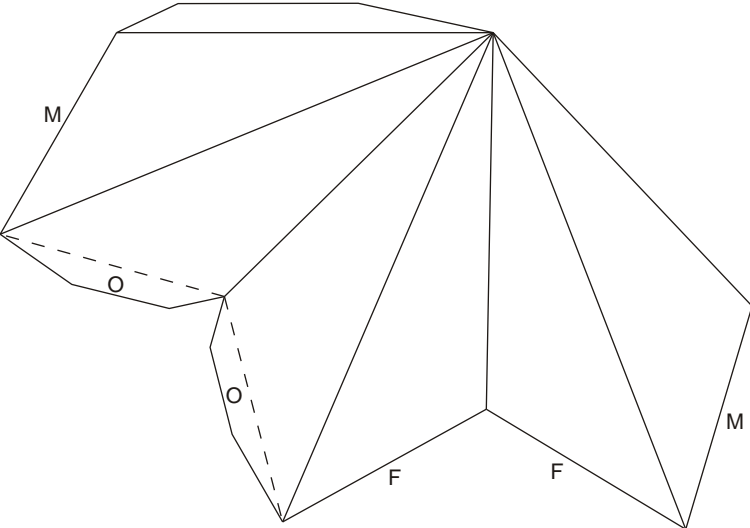

O

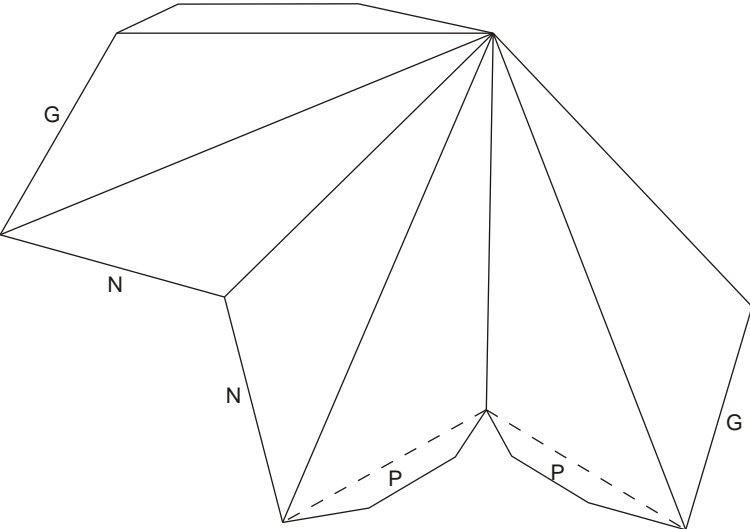



# Seventh Stellation of the Icosahedron

P

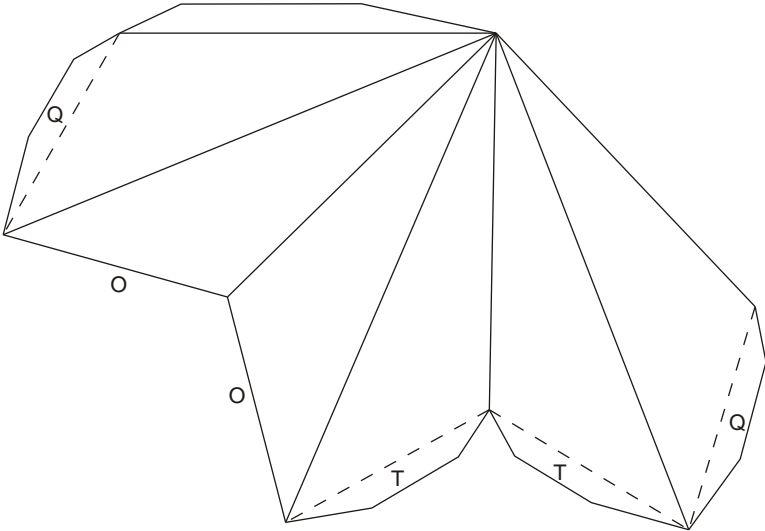

Q

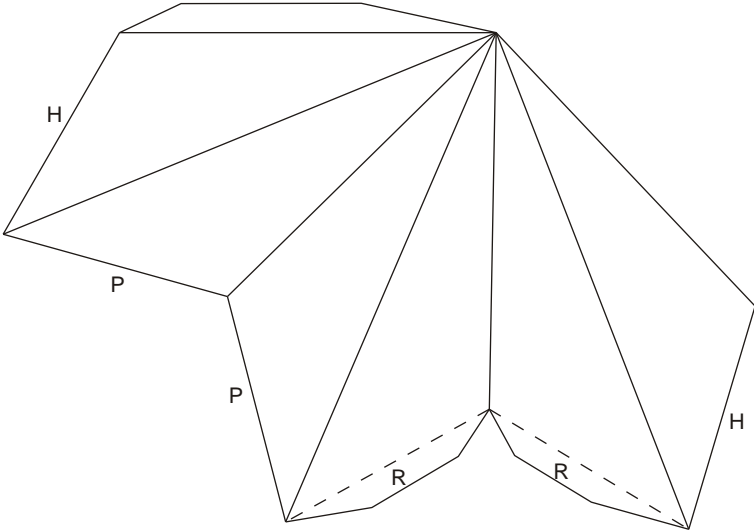

R

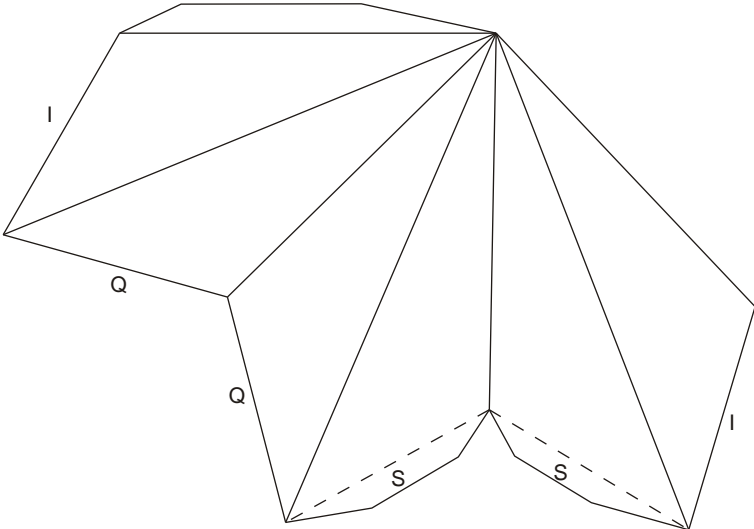

# Seventh Stellation of the Icosahedron

S

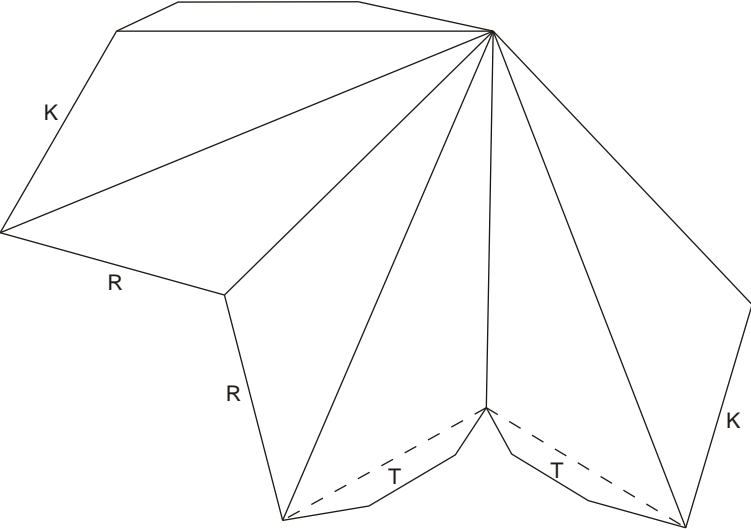

T

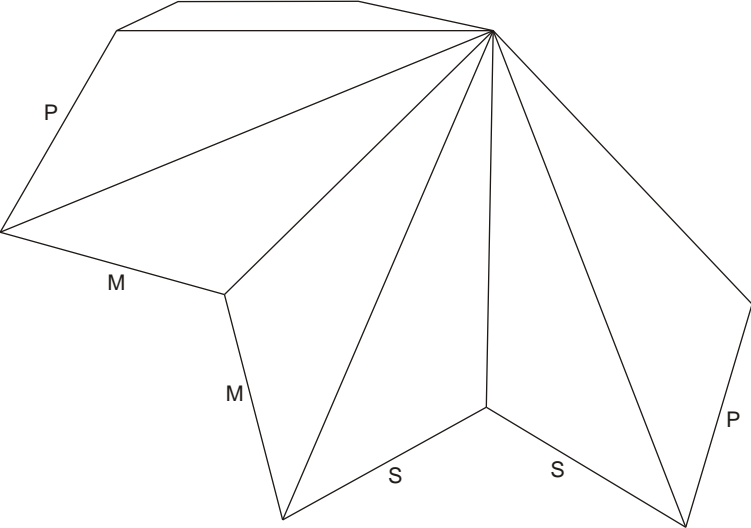

# Eighth Stellation of the Icosahedron

(Large version)

Fold dotted lines forwards

Fold other lines backwards

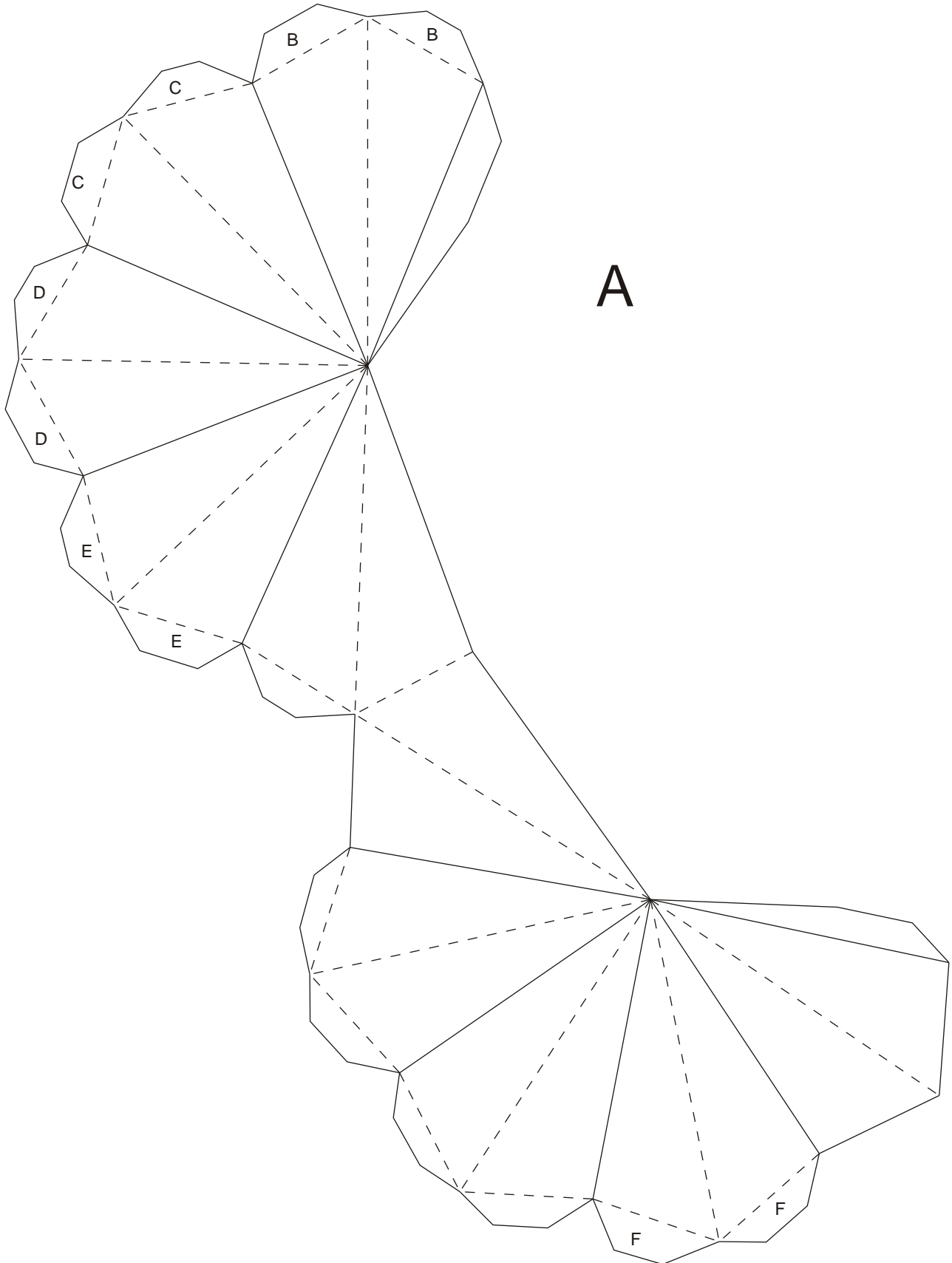

# Eighth Stellation of the Icosahedron

(Large version)

Fold dotted lines forwards

Fold other lines backwards

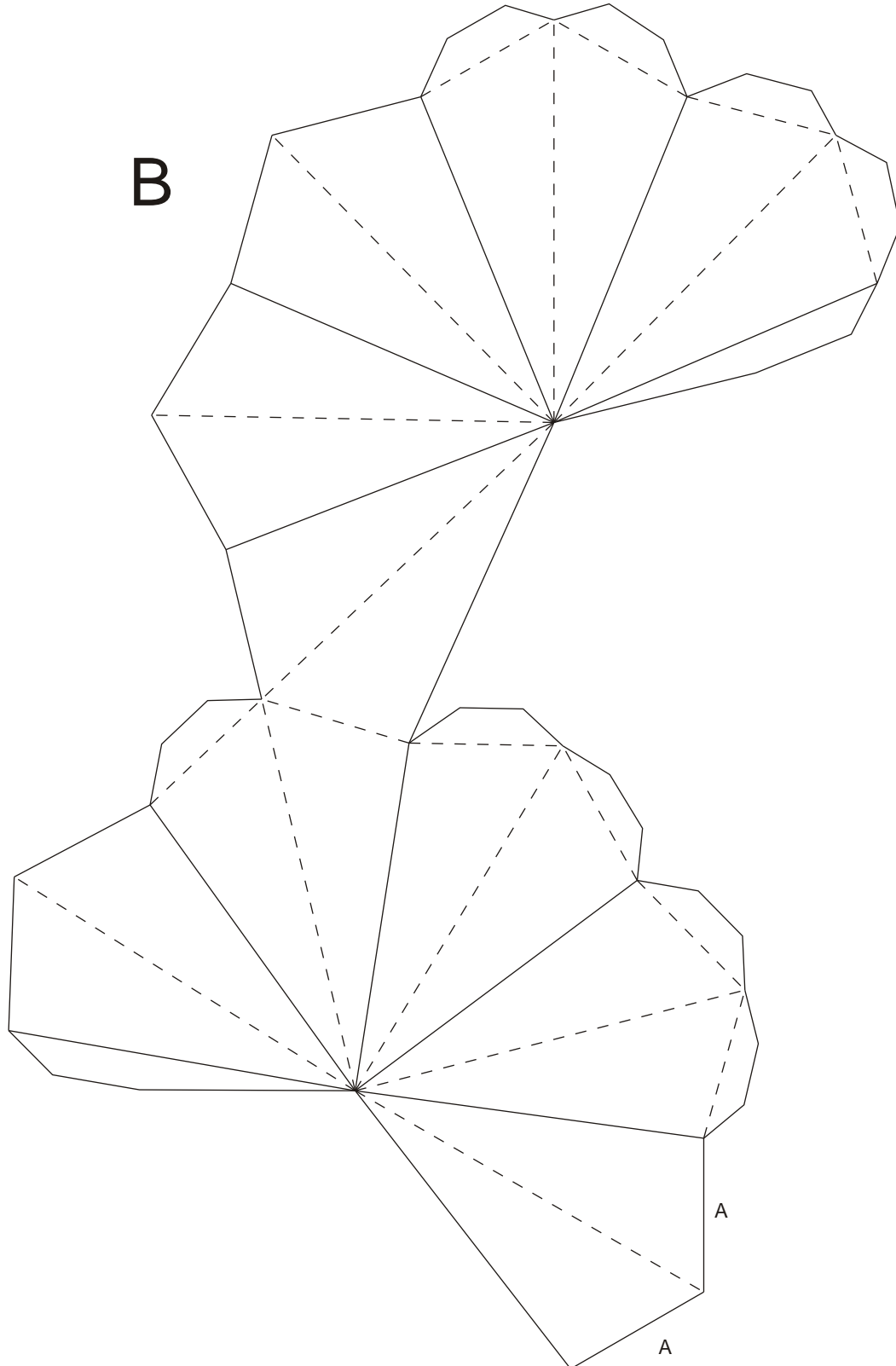

# Eighth Stellation of the Icosahedron

(Large version)

Fold dotted lines forwards

Fold other lines backwards

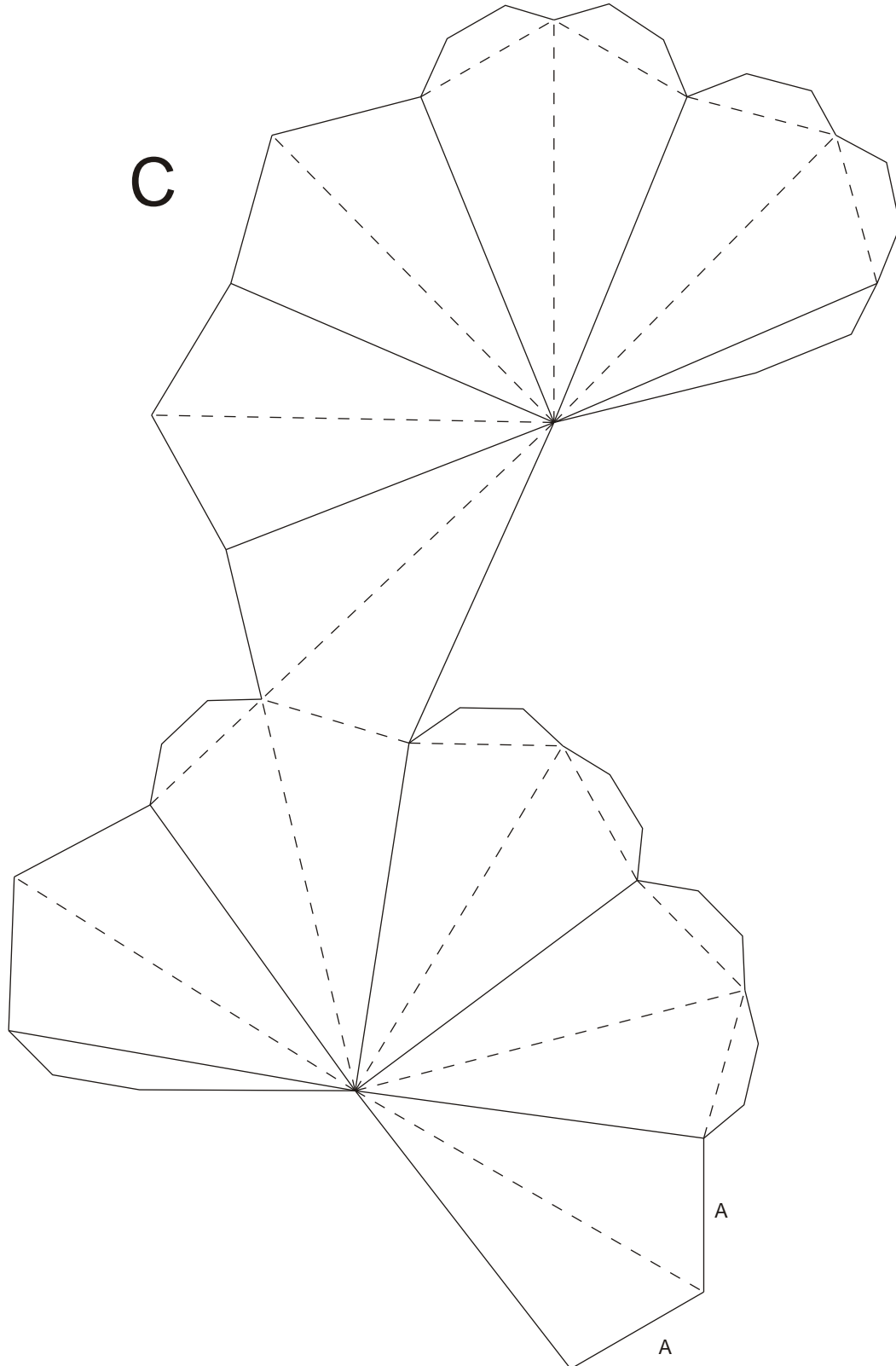

# Eighth Stellation of the Icosahedron

(Large version)

Fold dotted lines forwards

Fold other lines backwards

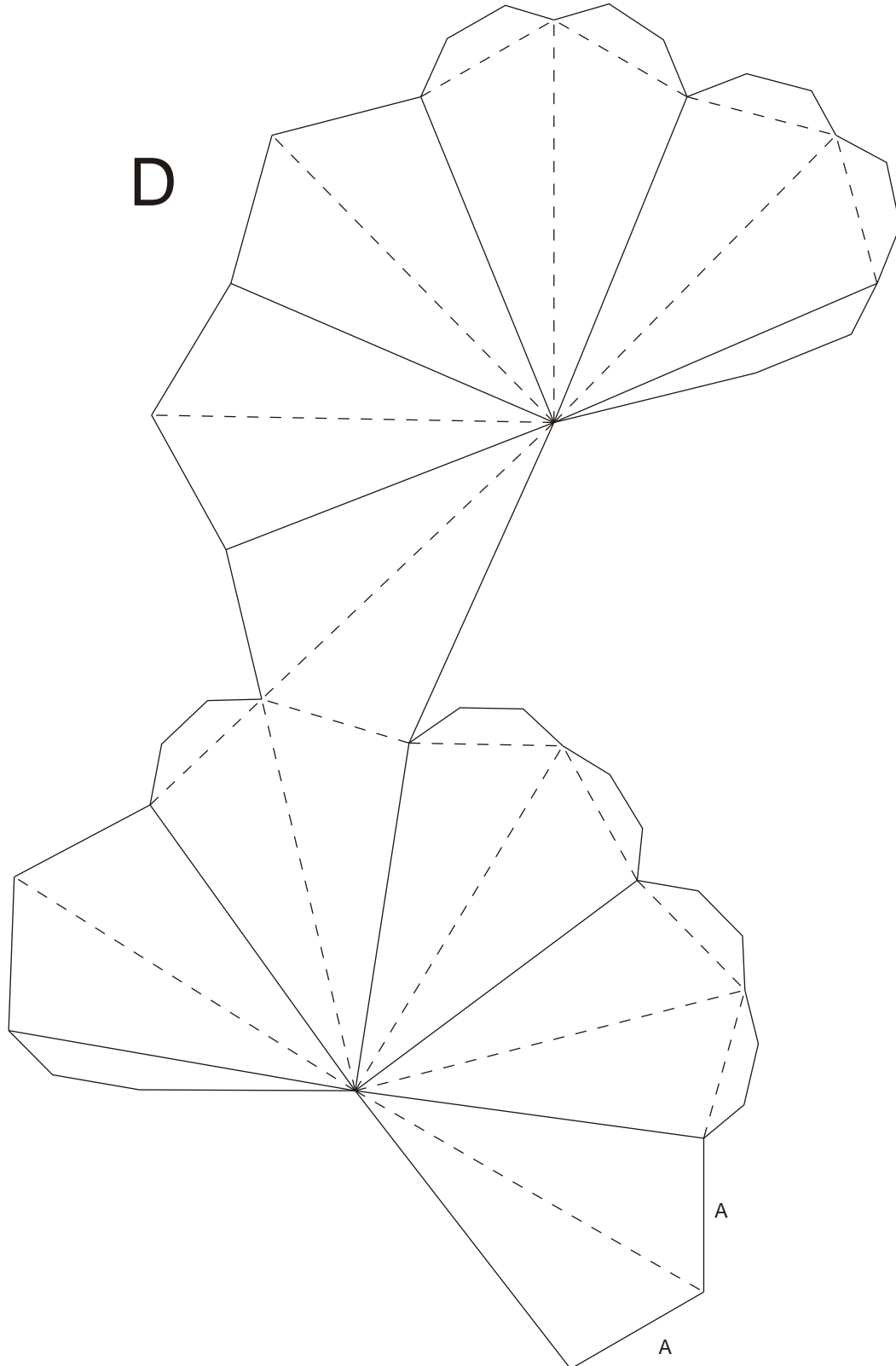

# Eighth Stellation of the Icosahedron

(Large version)

Fold dotted lines forwards

Fold other lines backwards

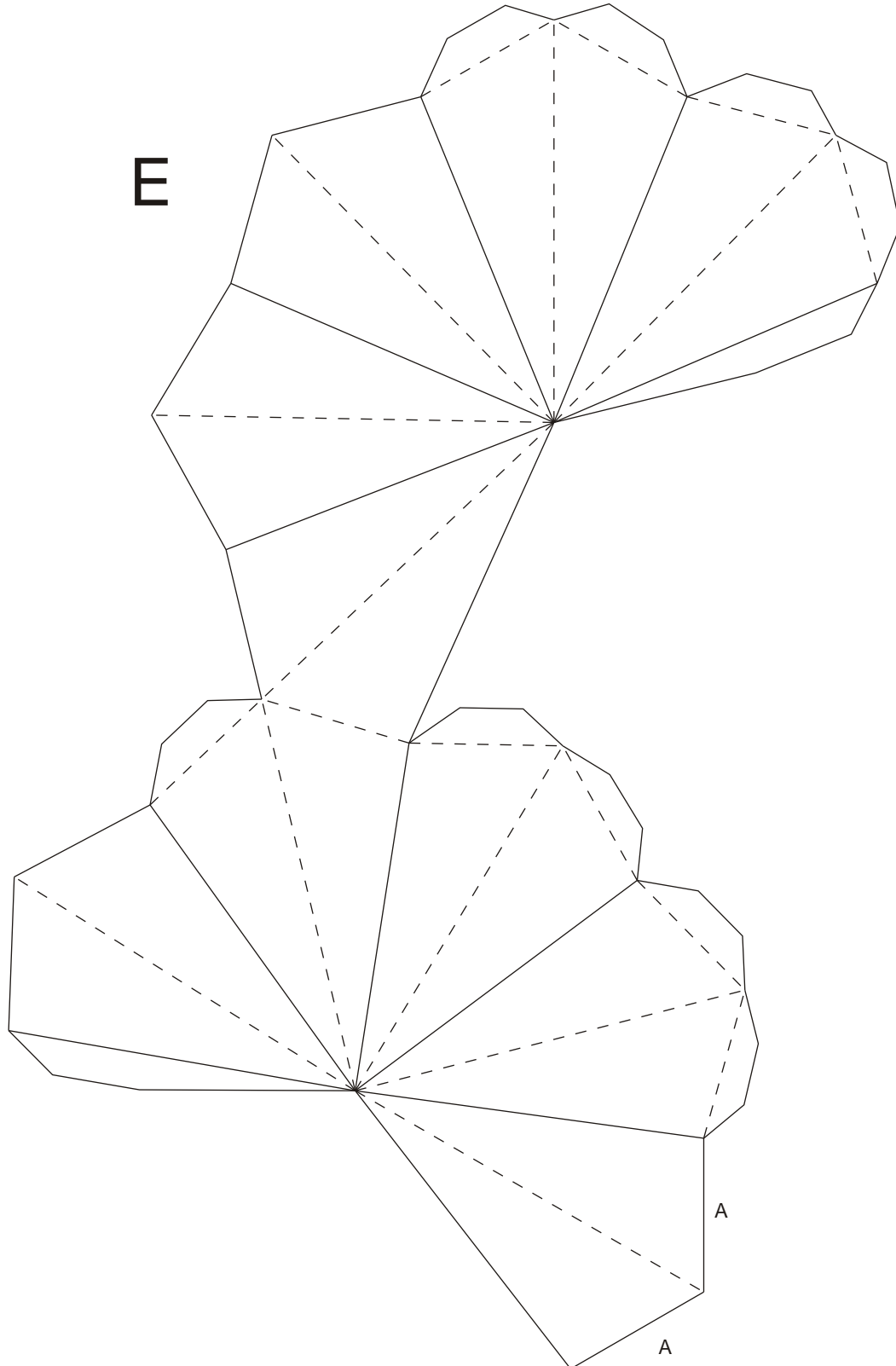

# Eighth Stellation of the Icosahedron

(Large version)

Hold dotted lines forwards

Fold other lines backwards

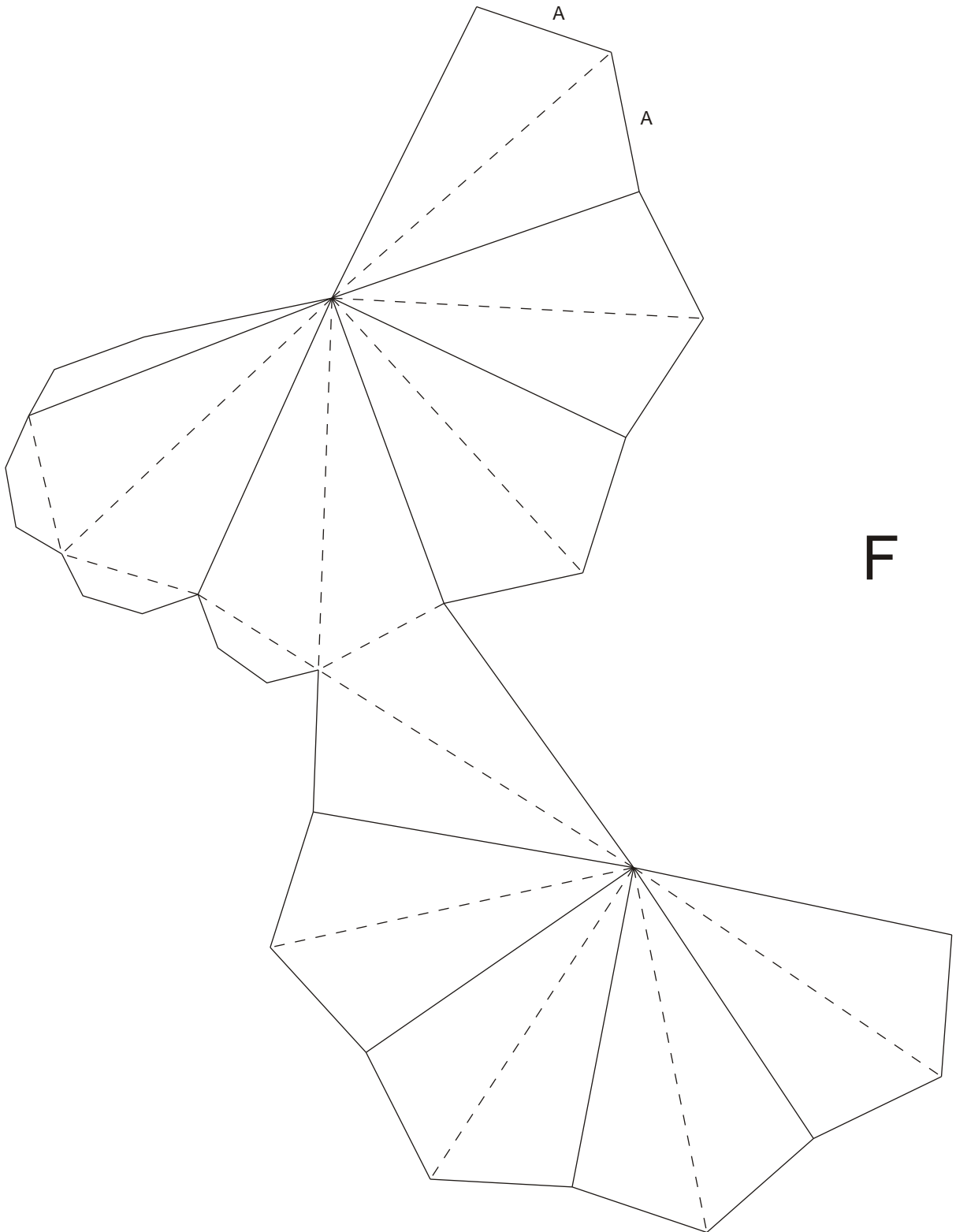



# Ninth Stellation of the Icosahedron

Fold the dotted lines forwards

Fold the other lines backwards

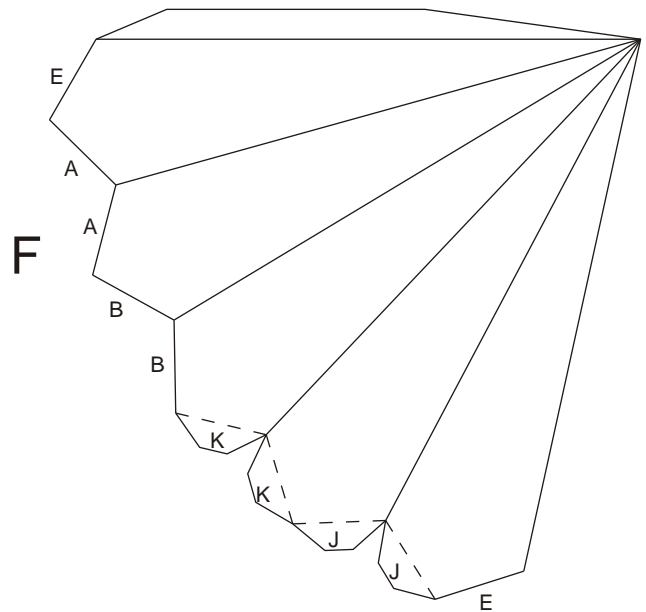
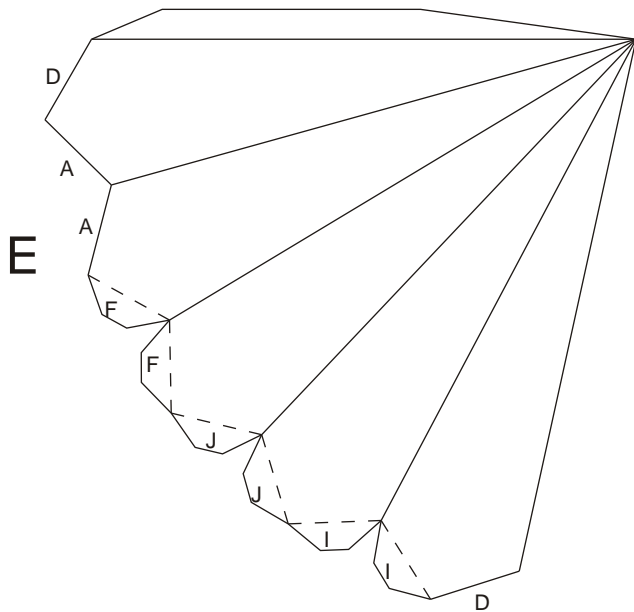
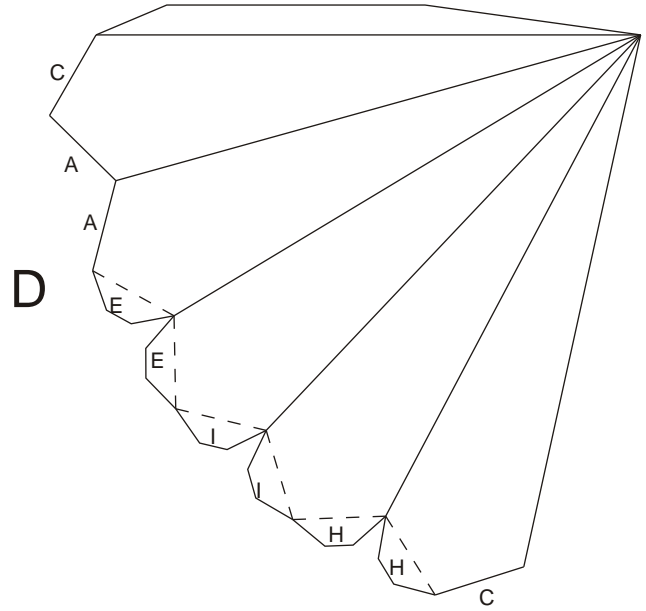
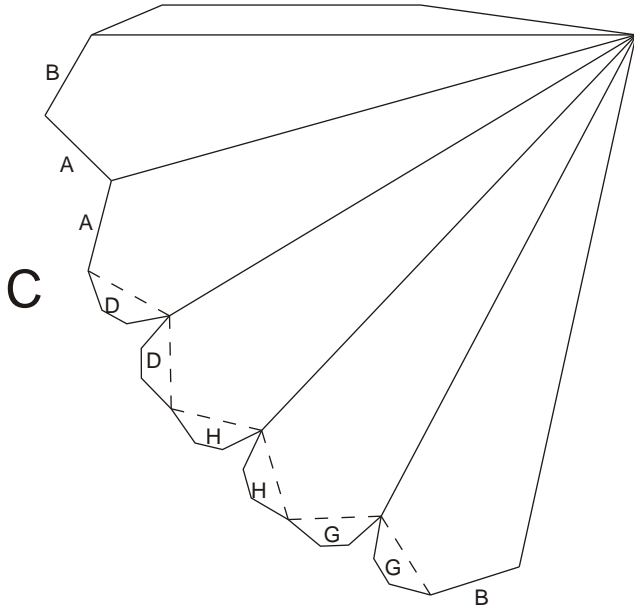
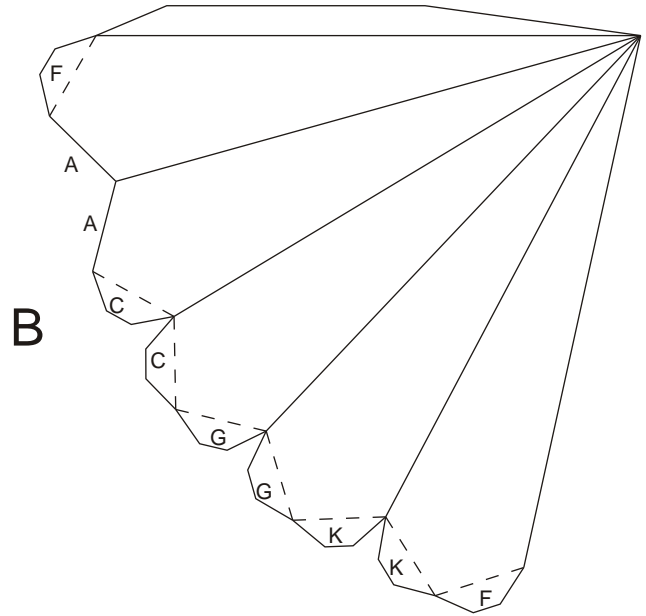
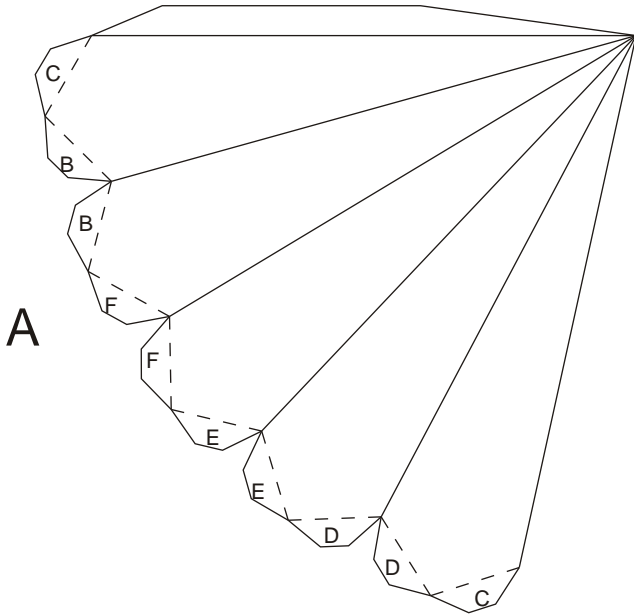

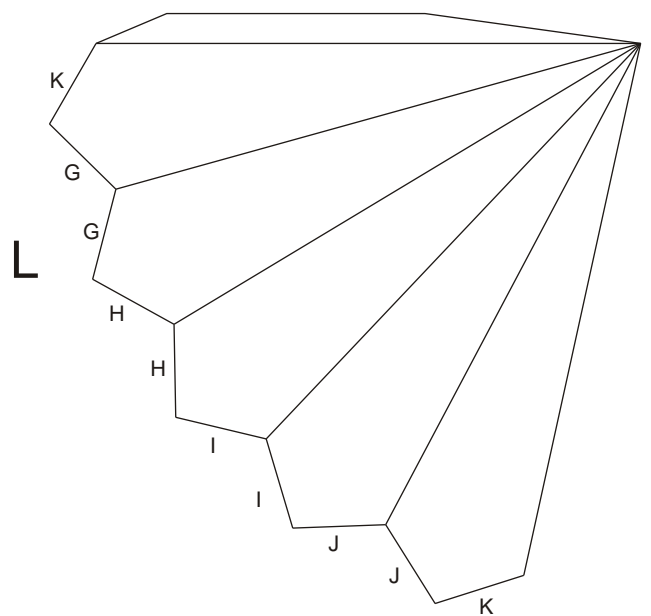
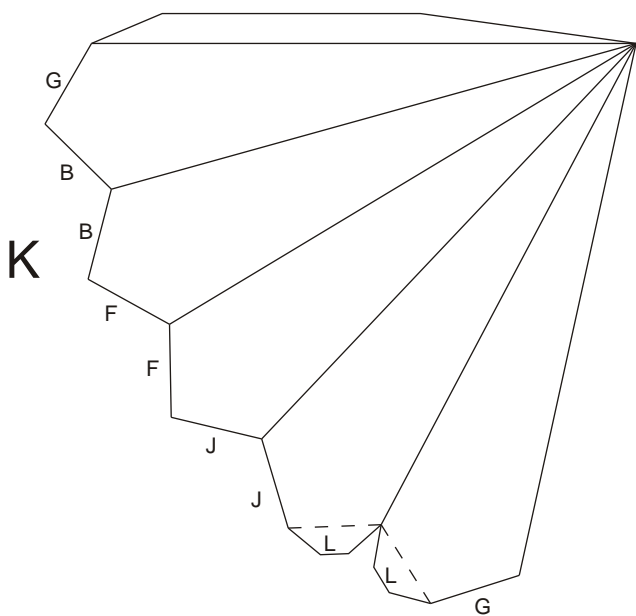
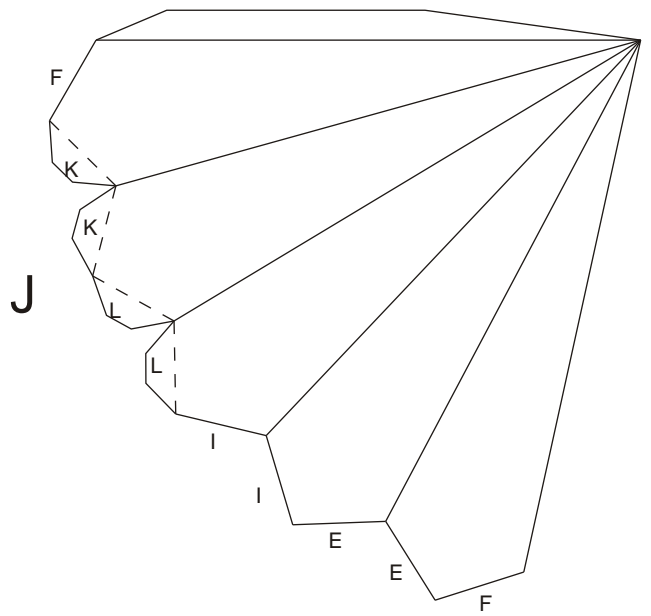
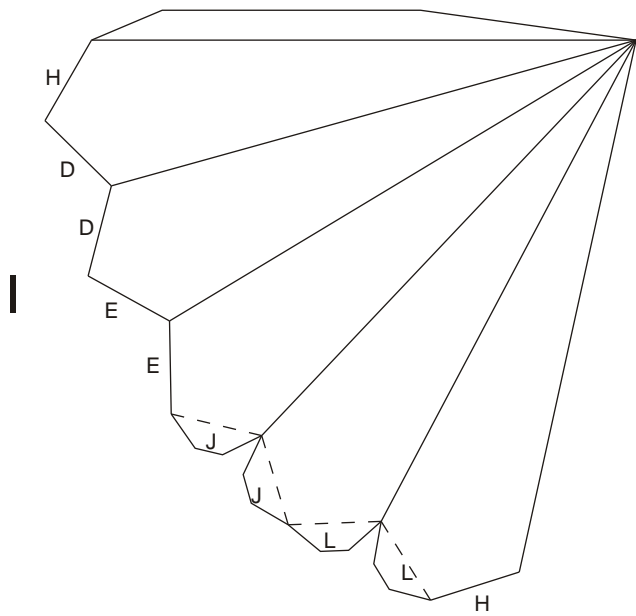
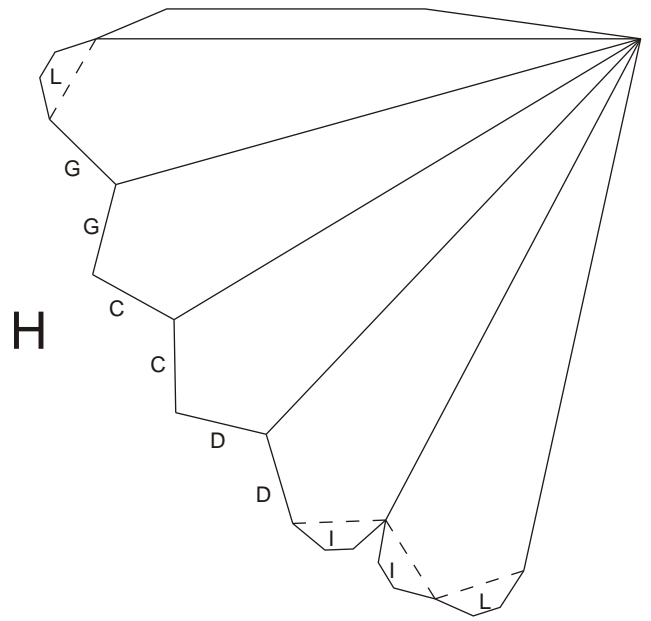
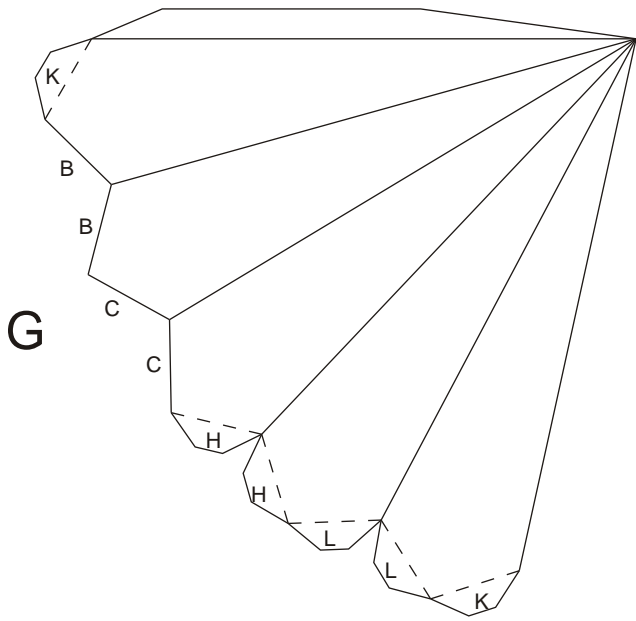

# Final Stellation of the icosahedron

Fold the dotted lines forwards  
Fold the other lines backwards

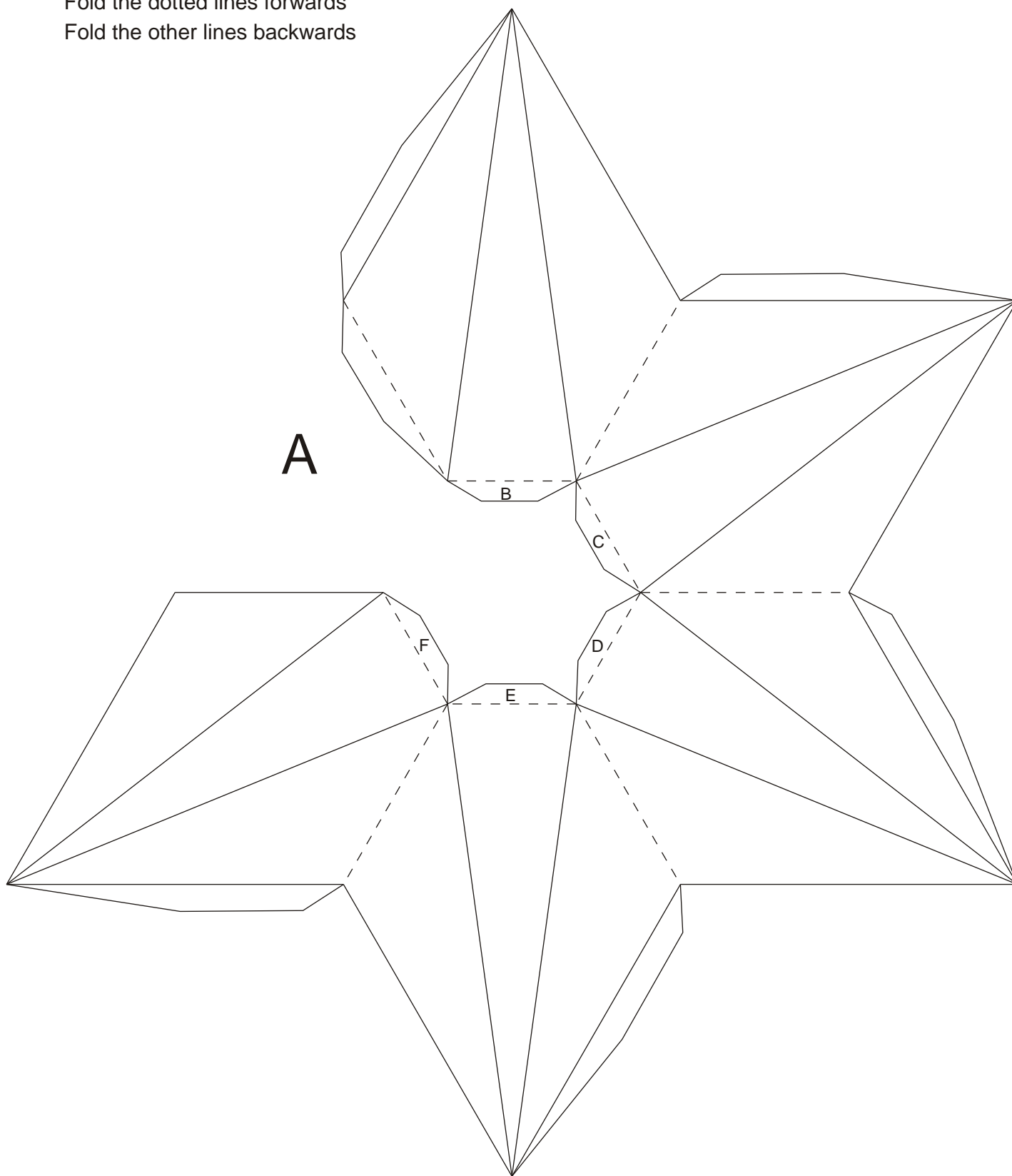

# Final Stellation of the icosahedron

Fold the dotted lines forwards  
Fold the other lines backwards

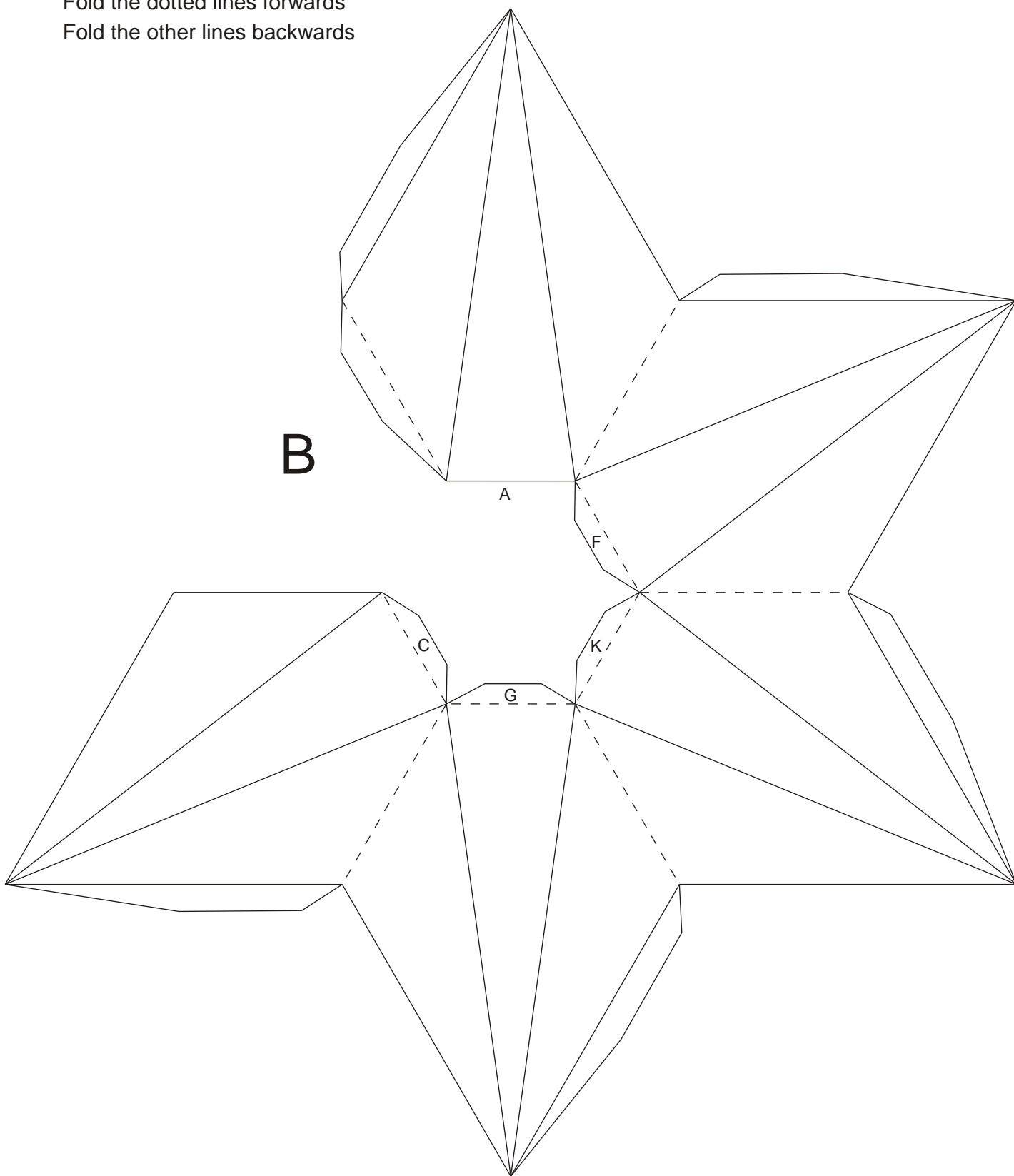

# Final Stellation of the icosahedron

Fold the dotted lines forwards  
Fold the other lines backwards

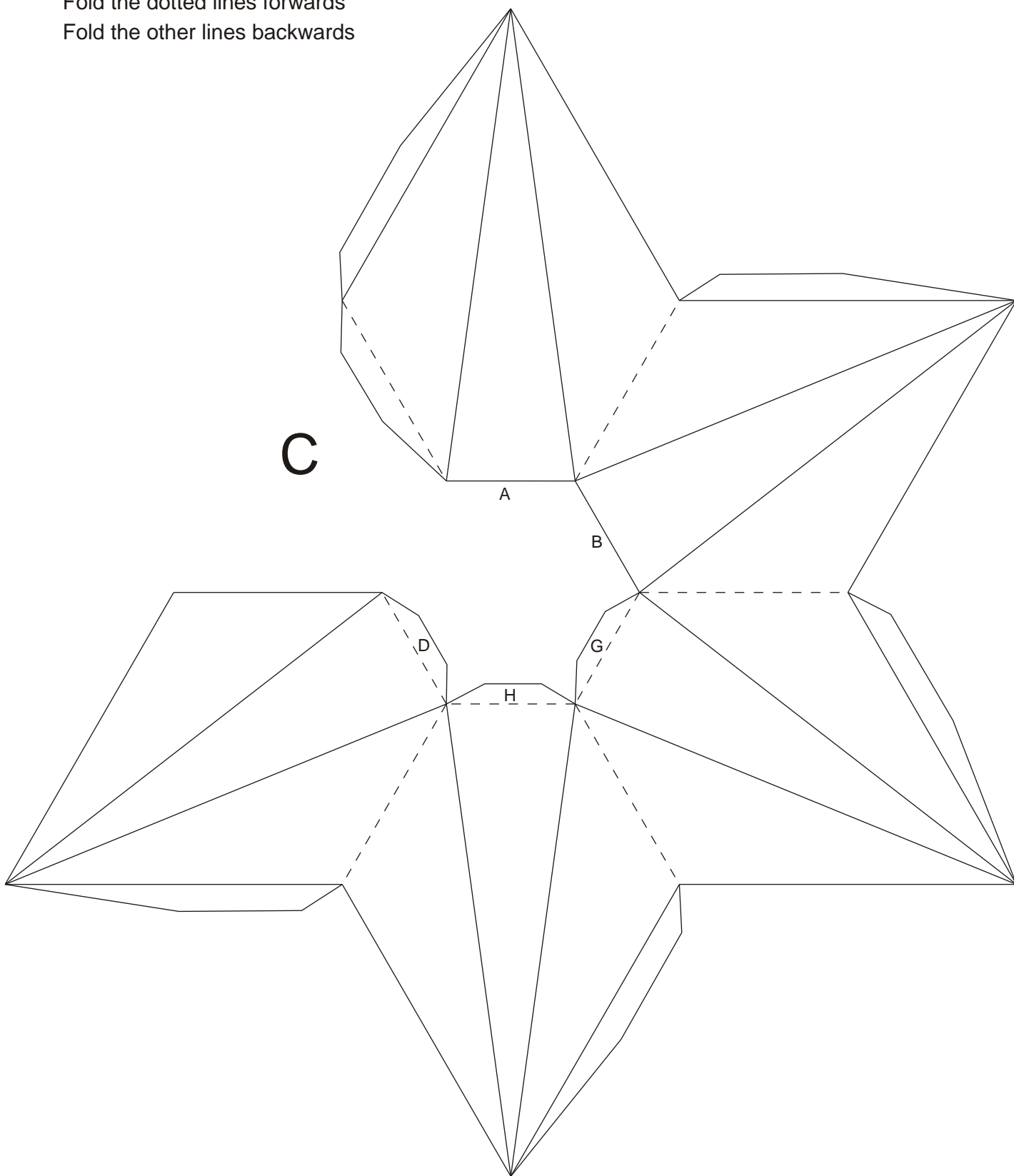

# Final Stellation of the icosahedron

Fold the dotted lines forwards  
Fold the other lines backwards

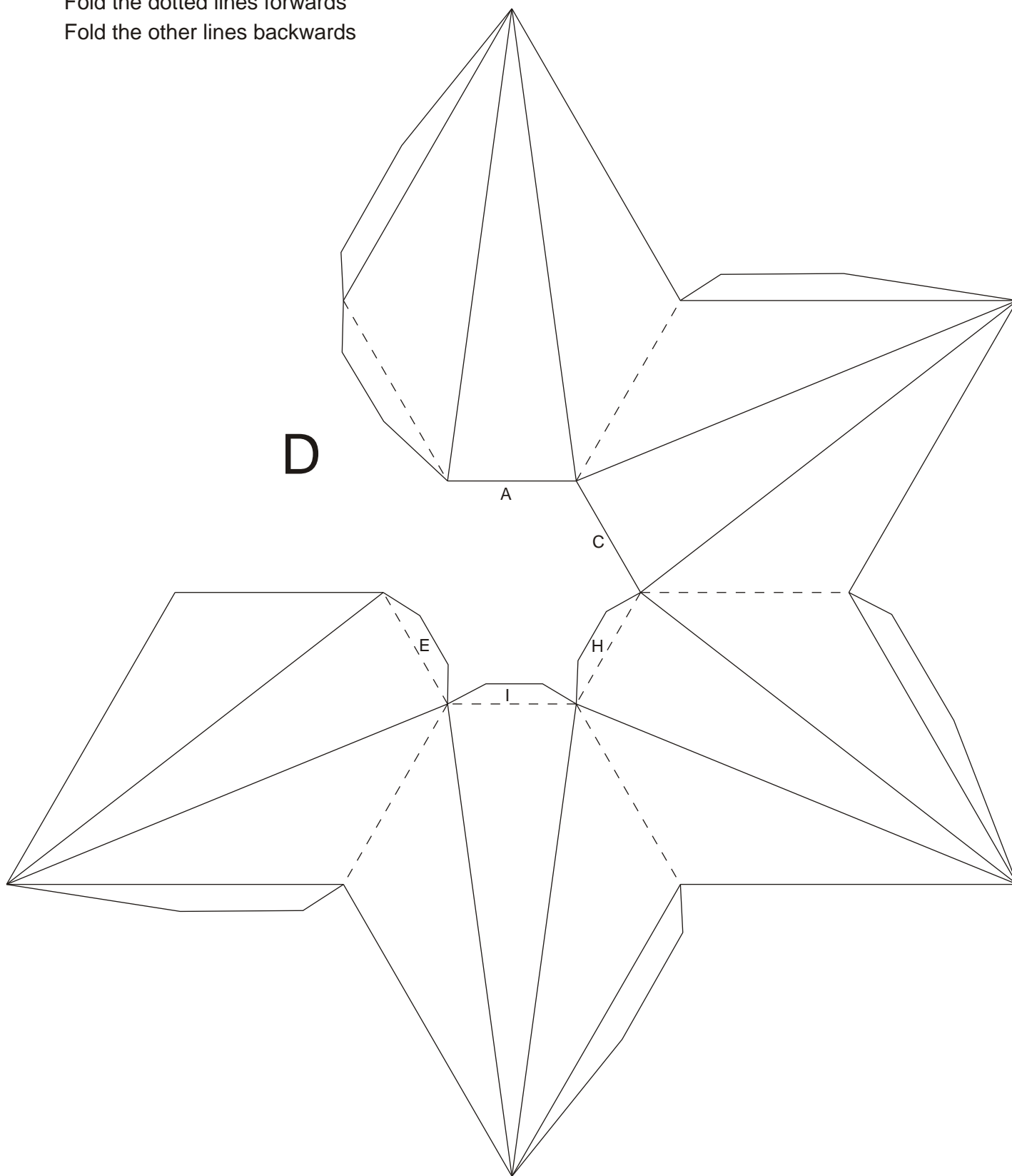

# Final Stellation of the icosahedron

Fold the dotted lines forwards  
Fold the other lines backwards

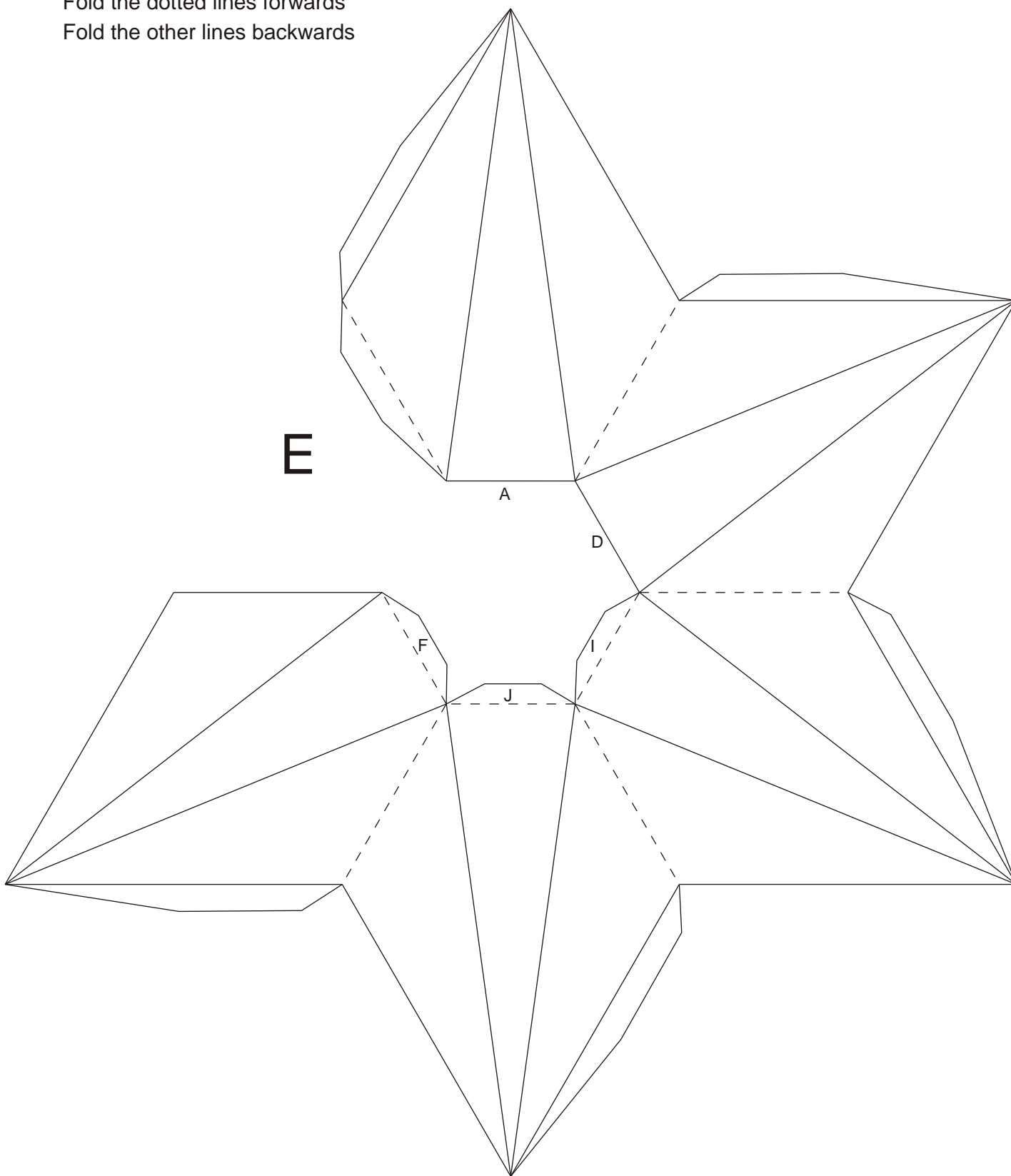

# Final Stellation of the icosahedron

Fold the dotted lines forwards  
Fold the other lines backwards

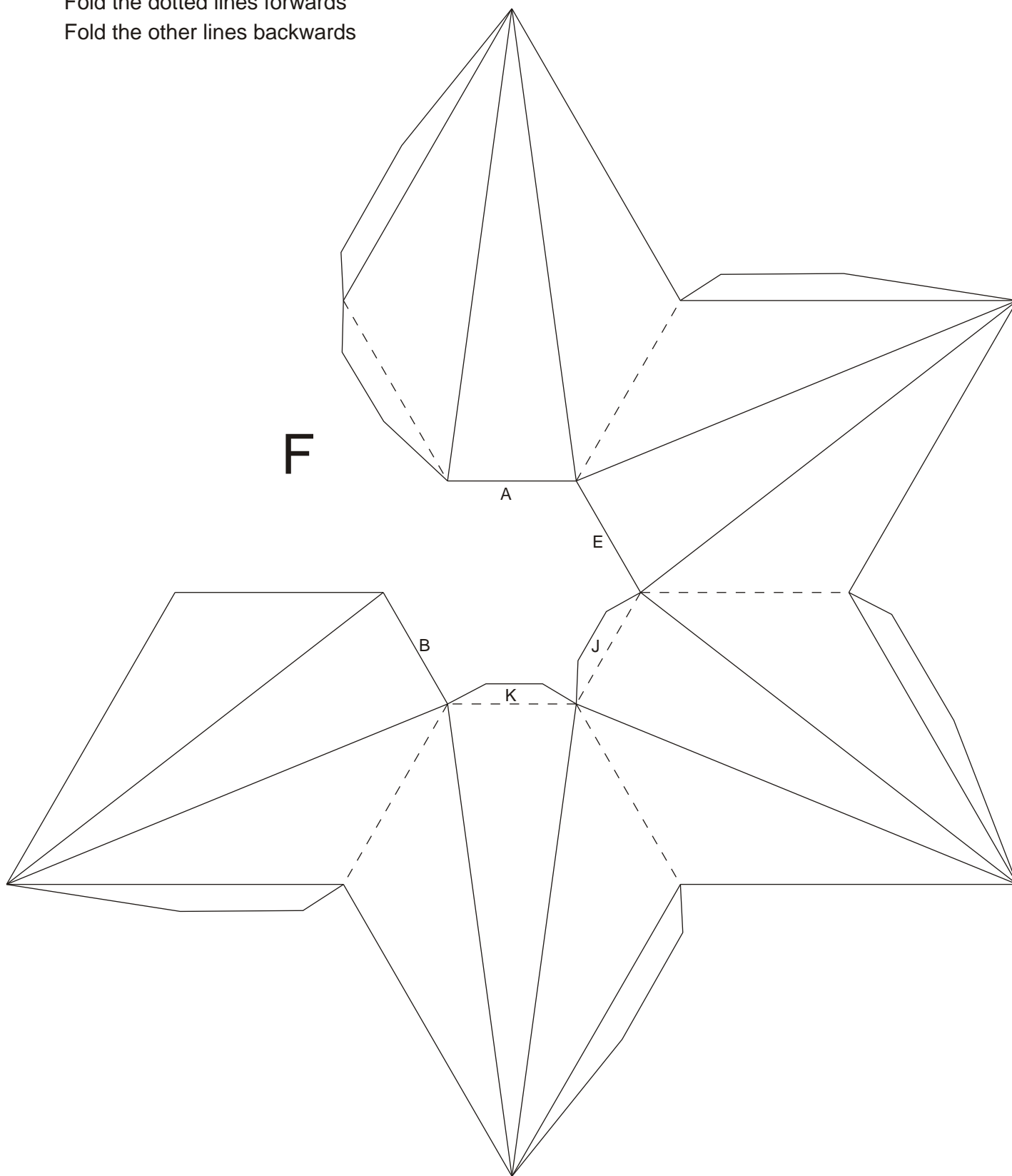



# Final Stellation of the icosahedron

Fold the dotted lines forwards  
Fold the other lines backwards

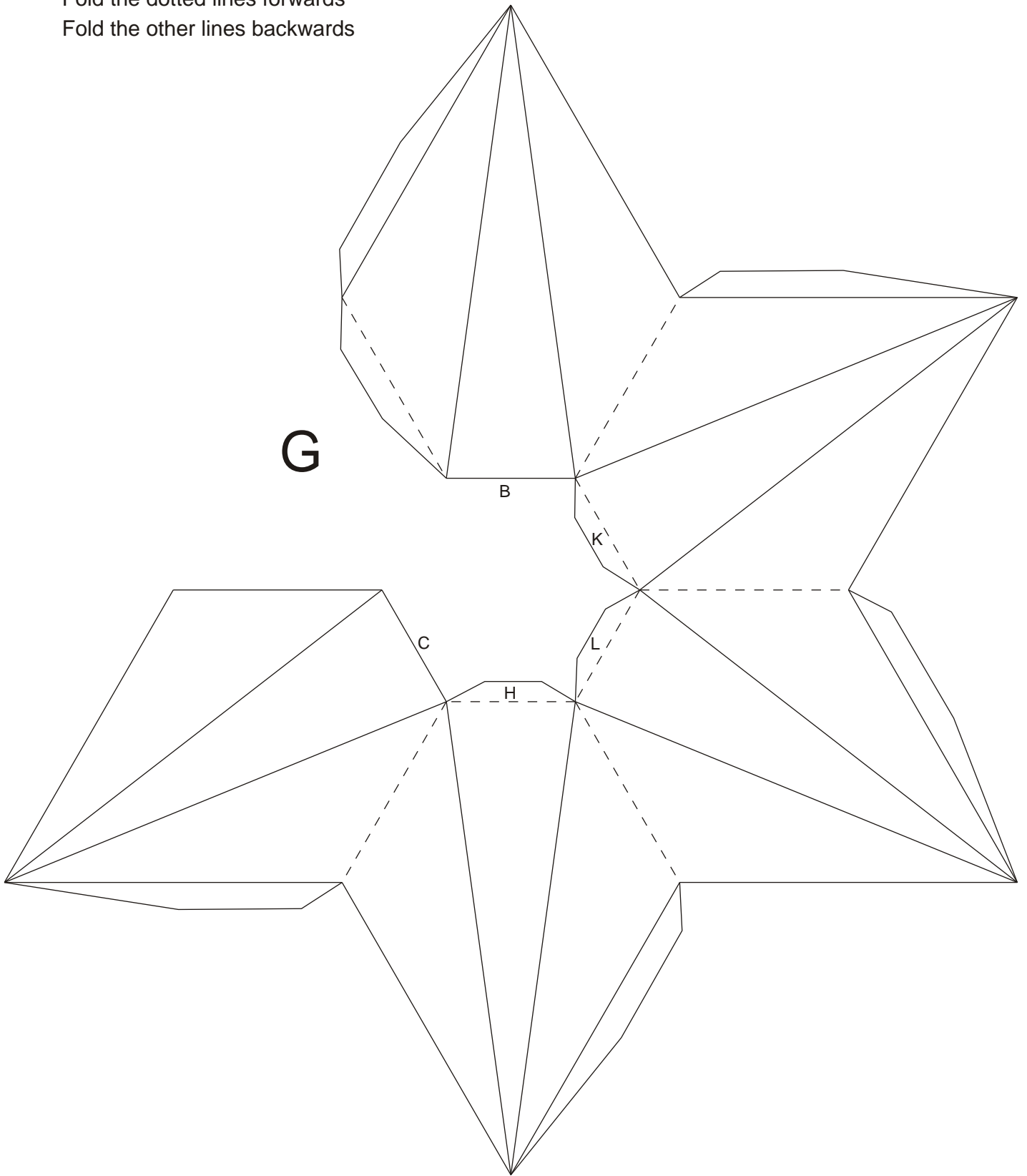

# Final Stellation of the icosahedron

Fold the dotted lines forwards  
Fold the other lines backwards

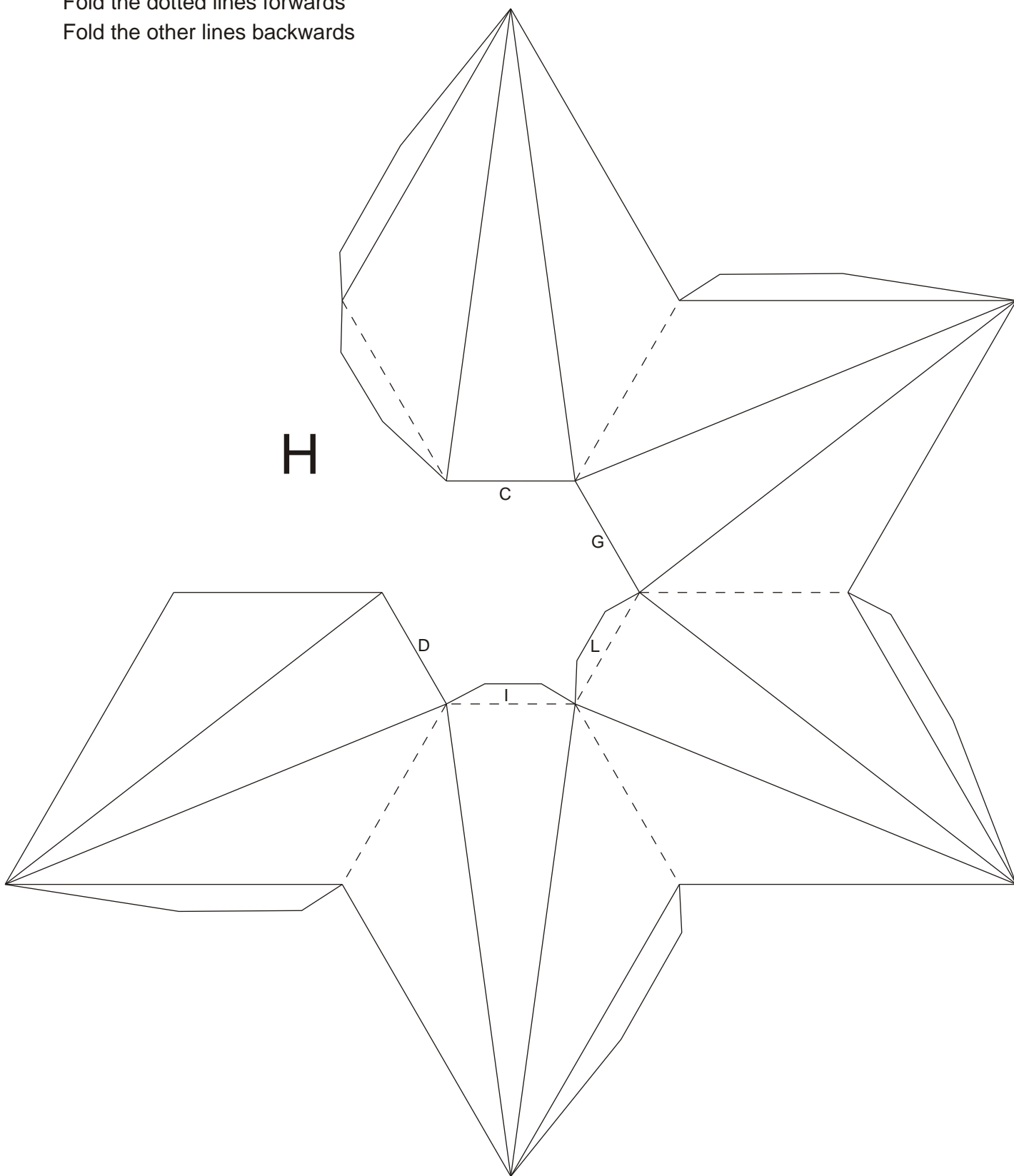

# Final Stellation of the icosahedron

Fold the dotted lines forwards  
Fold the other lines backwards

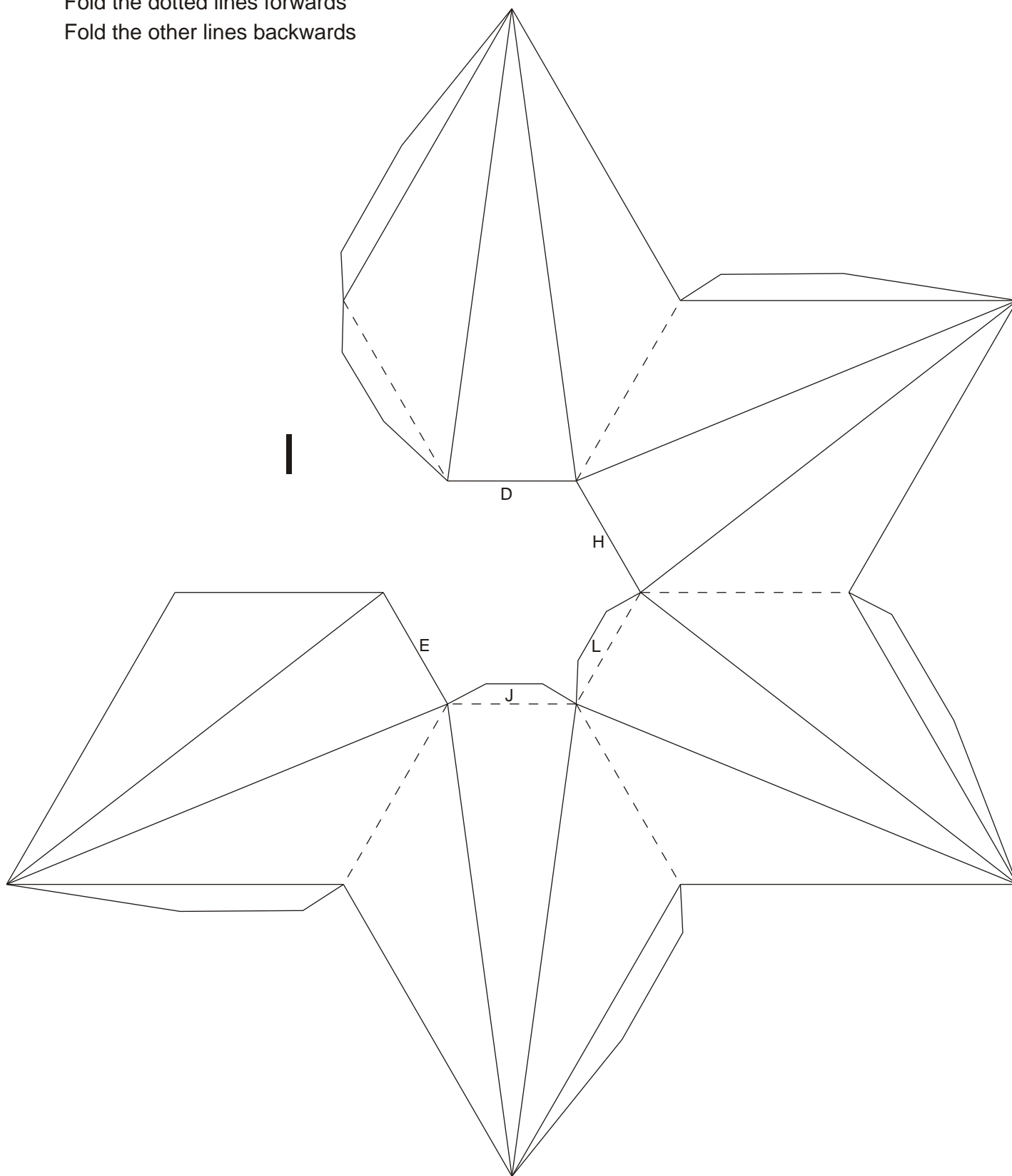

# Final Stellation of the icosahedron

Fold the dotted lines forwards  
Fold the other lines backwards

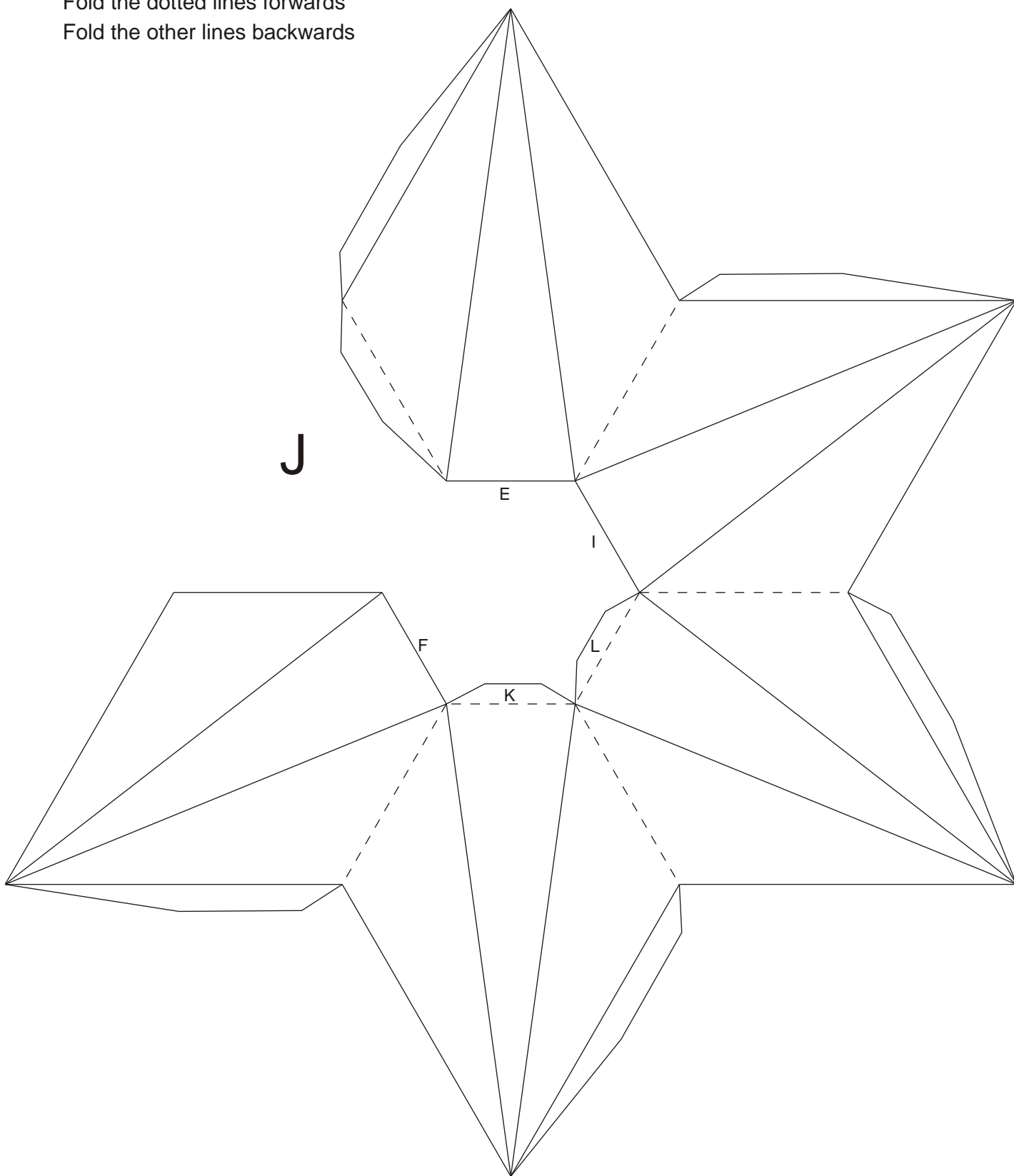

# Final Stellation of the icosahedron

Fold the dotted lines forwards  
Fold the other lines backwards

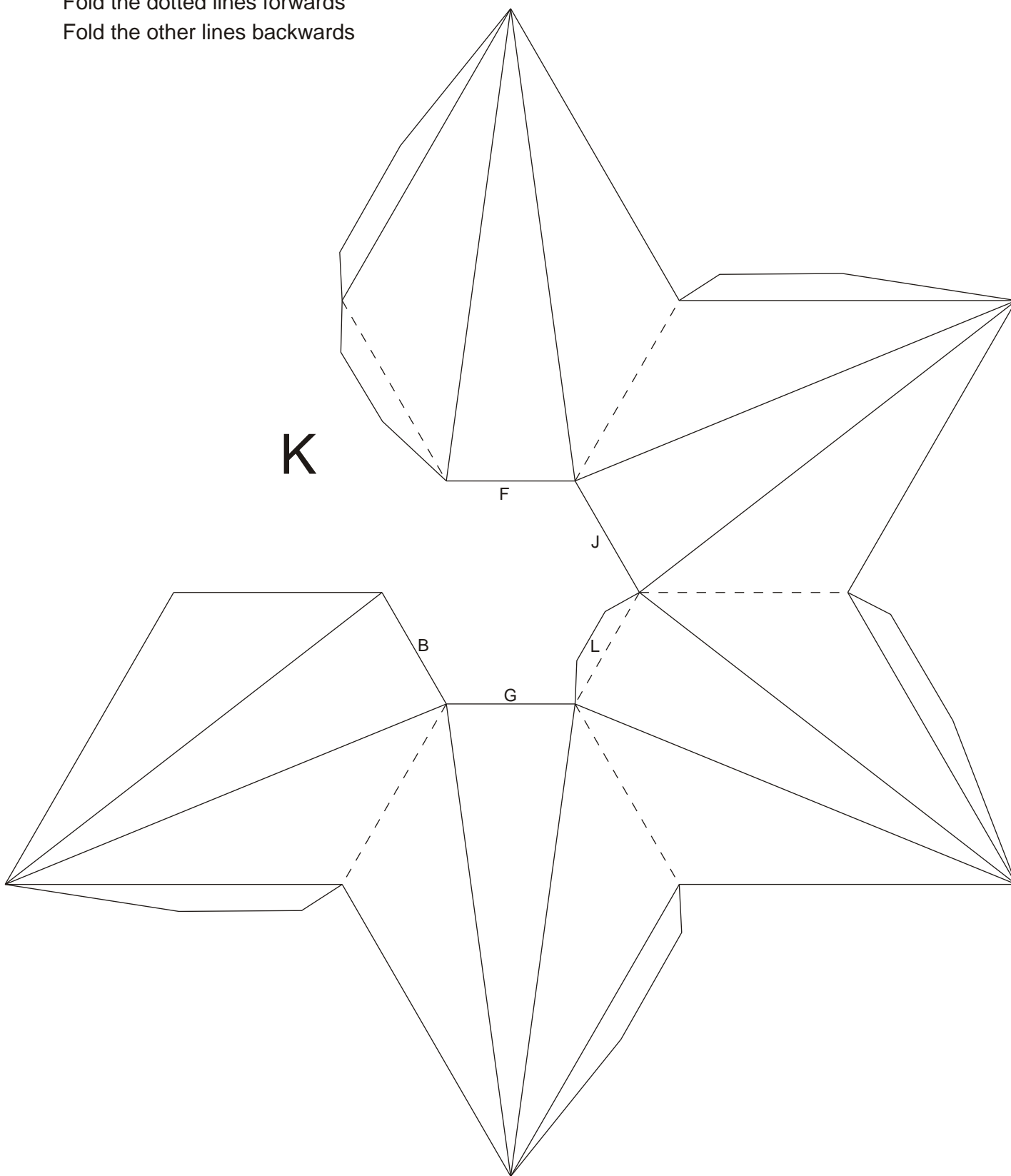

# Final Stellation of the icosahedron

Fold the dotted lines forwards  
Fold the other lines backwards

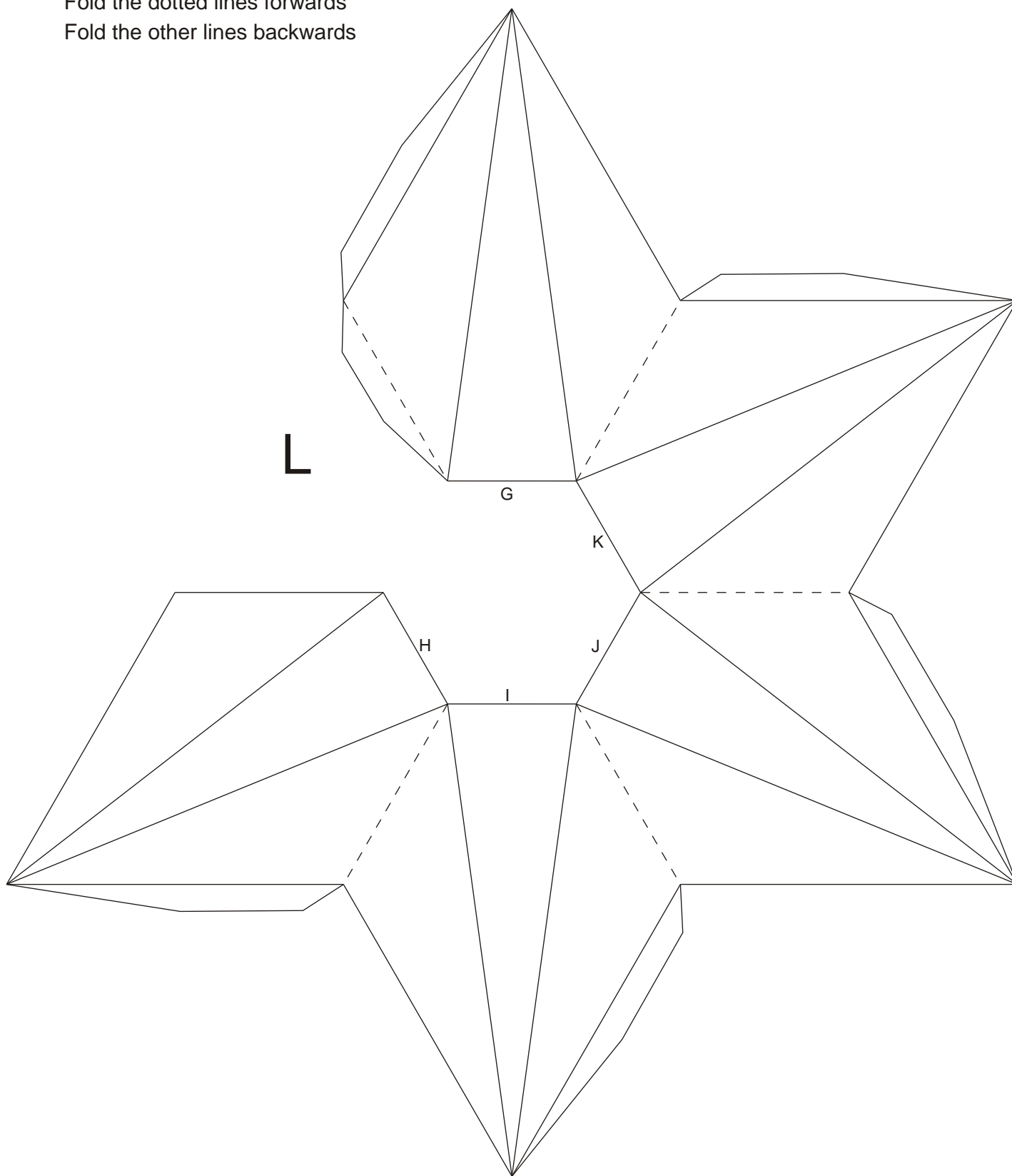

# Triangular prisms

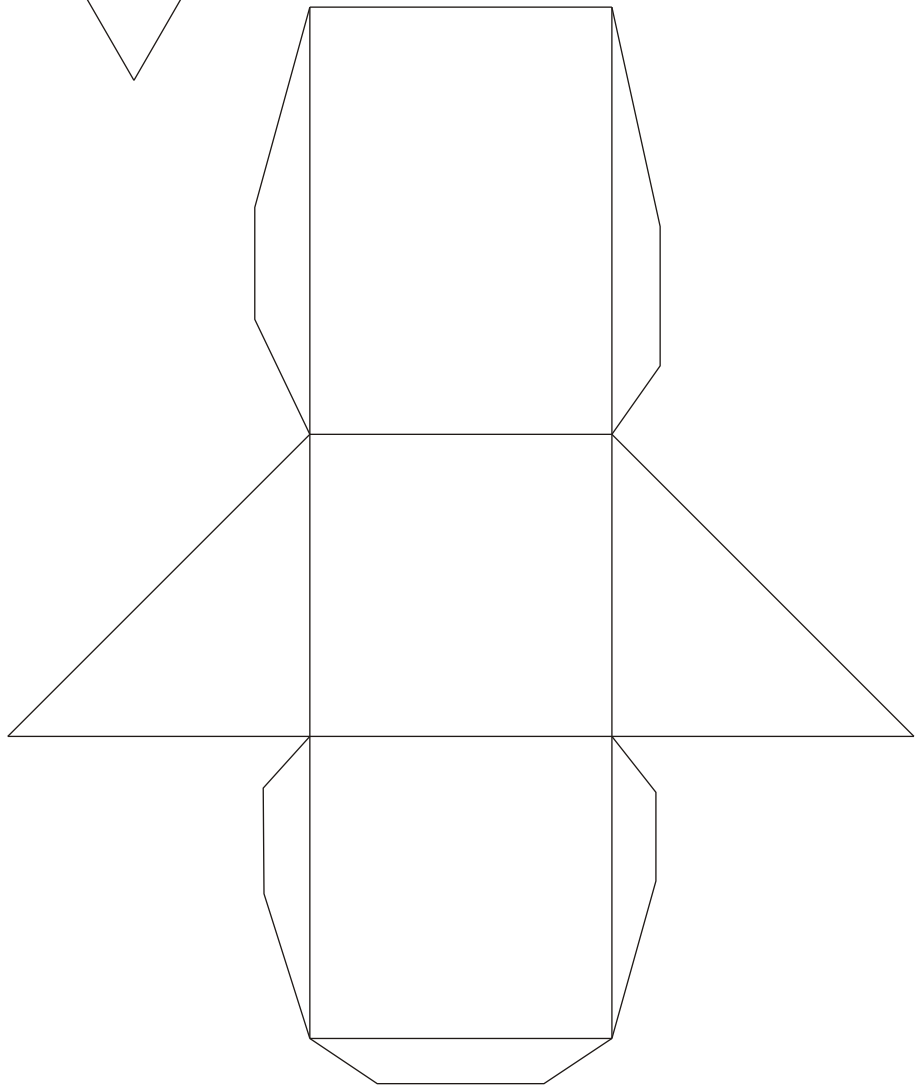
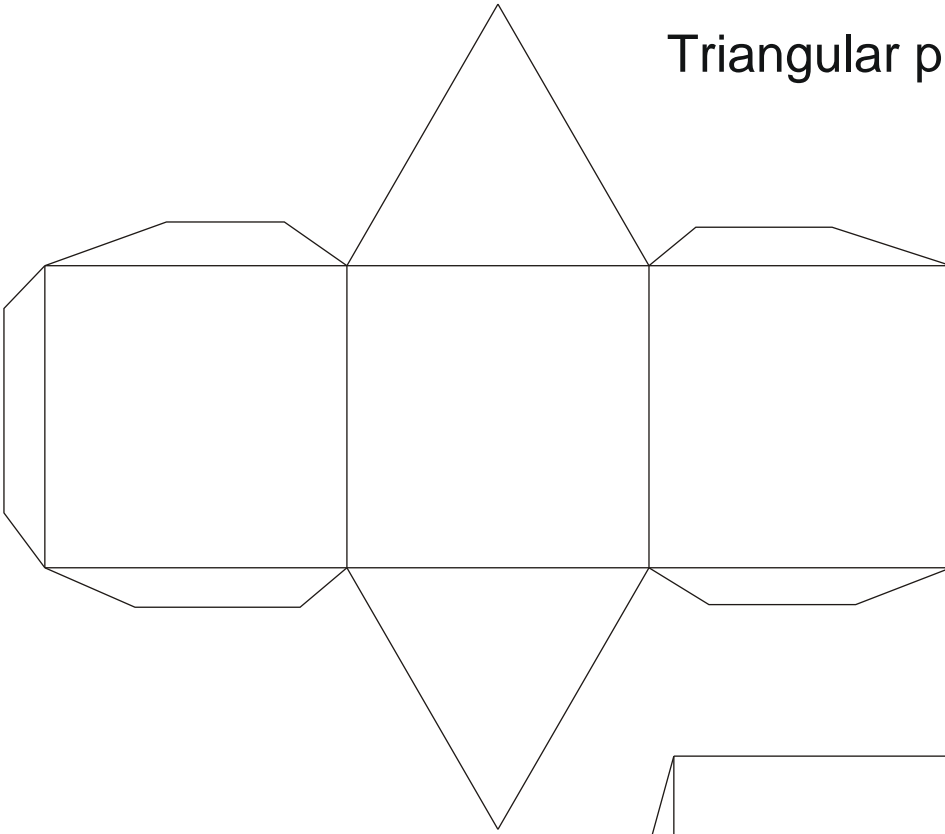

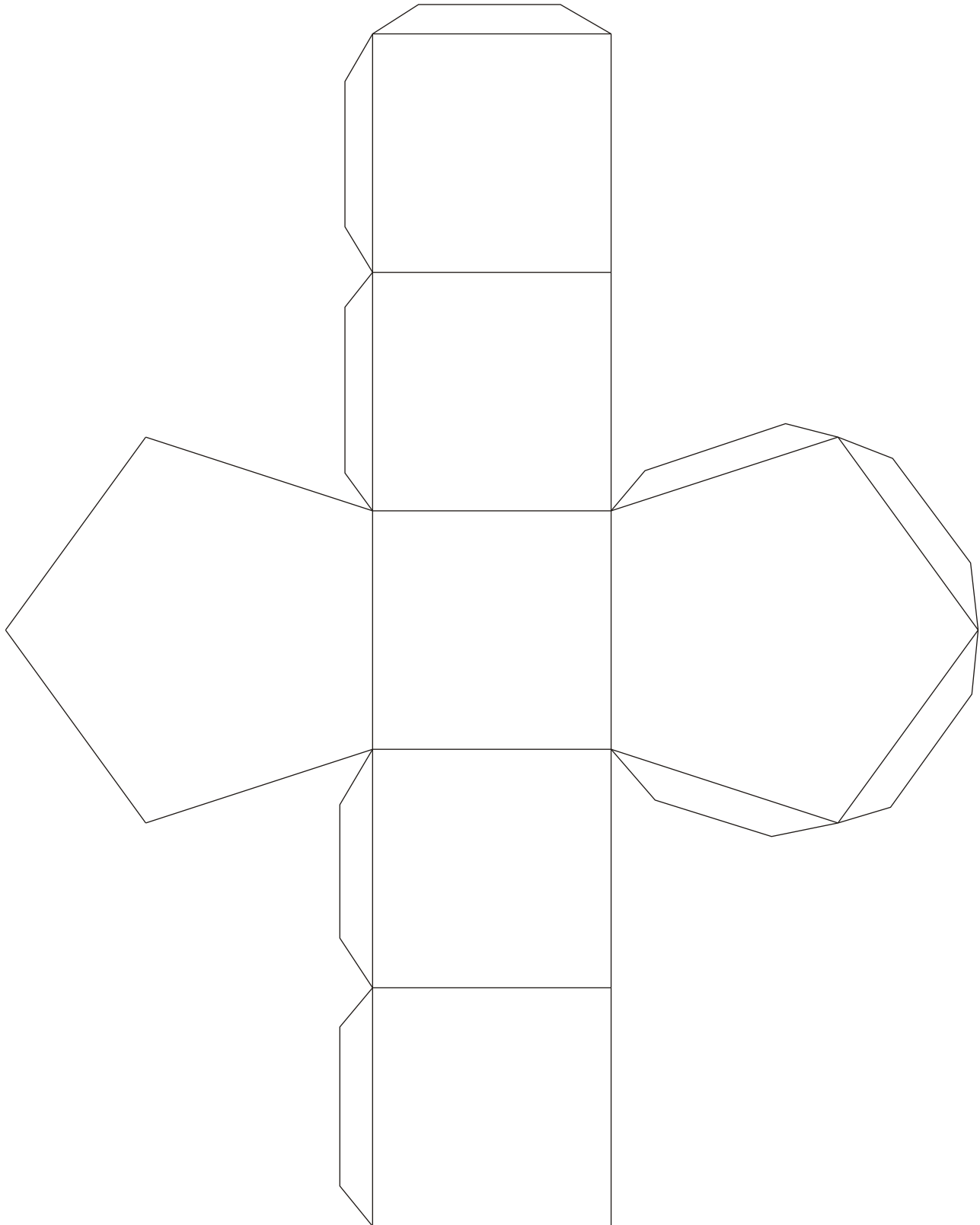



*Pentagonal Antiprism*

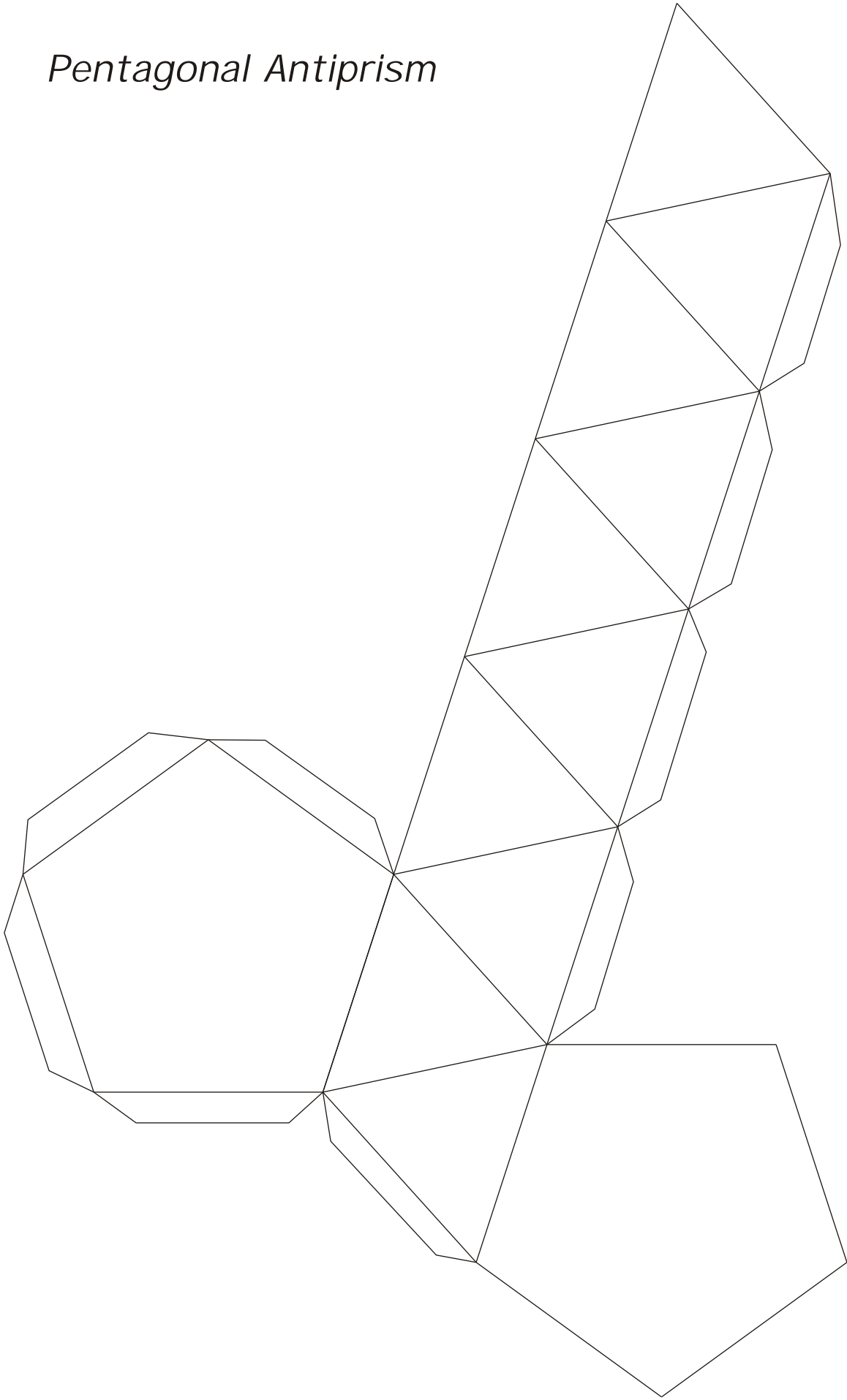

# Octagonal Prism

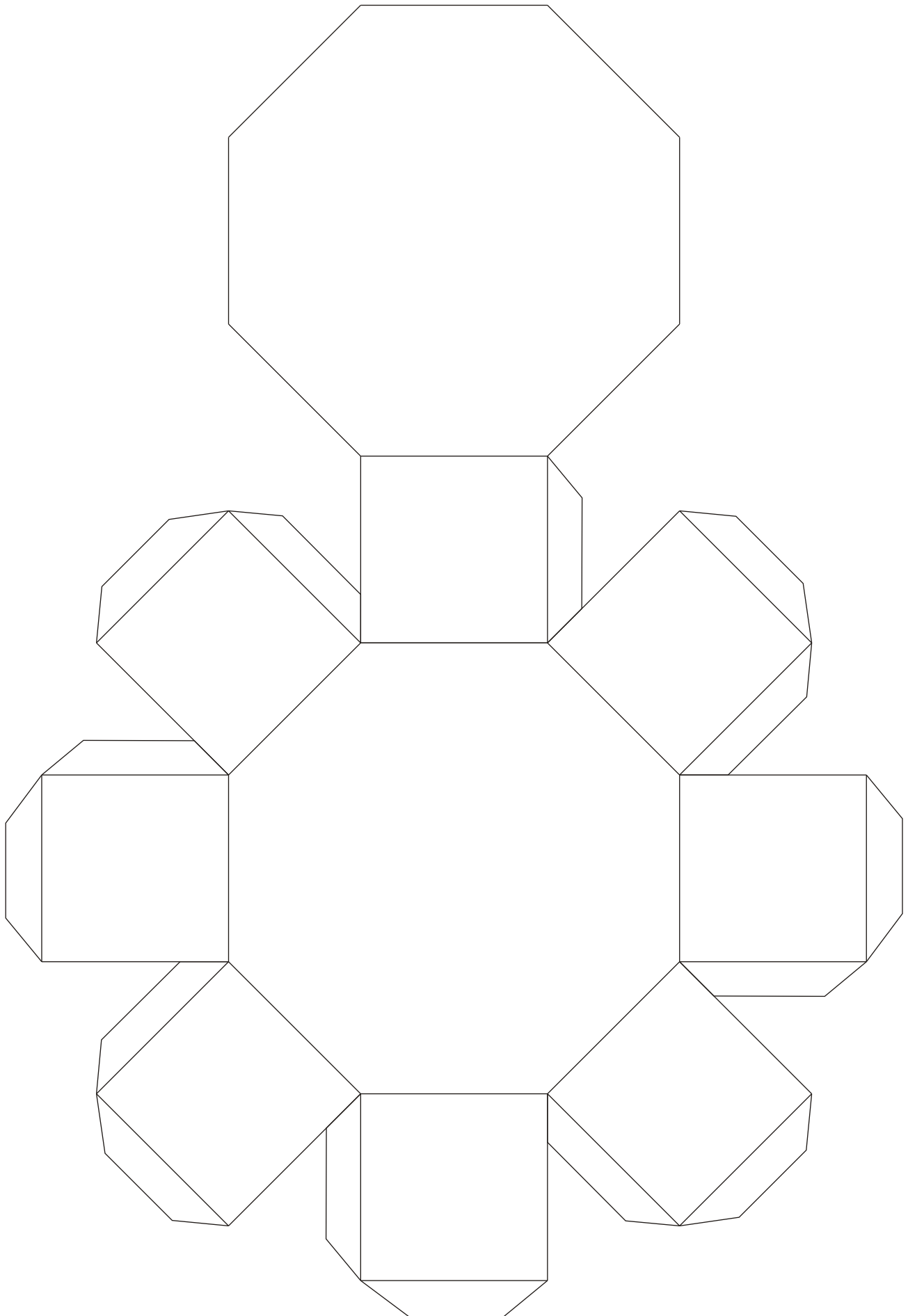

# Octagonal Antiprism

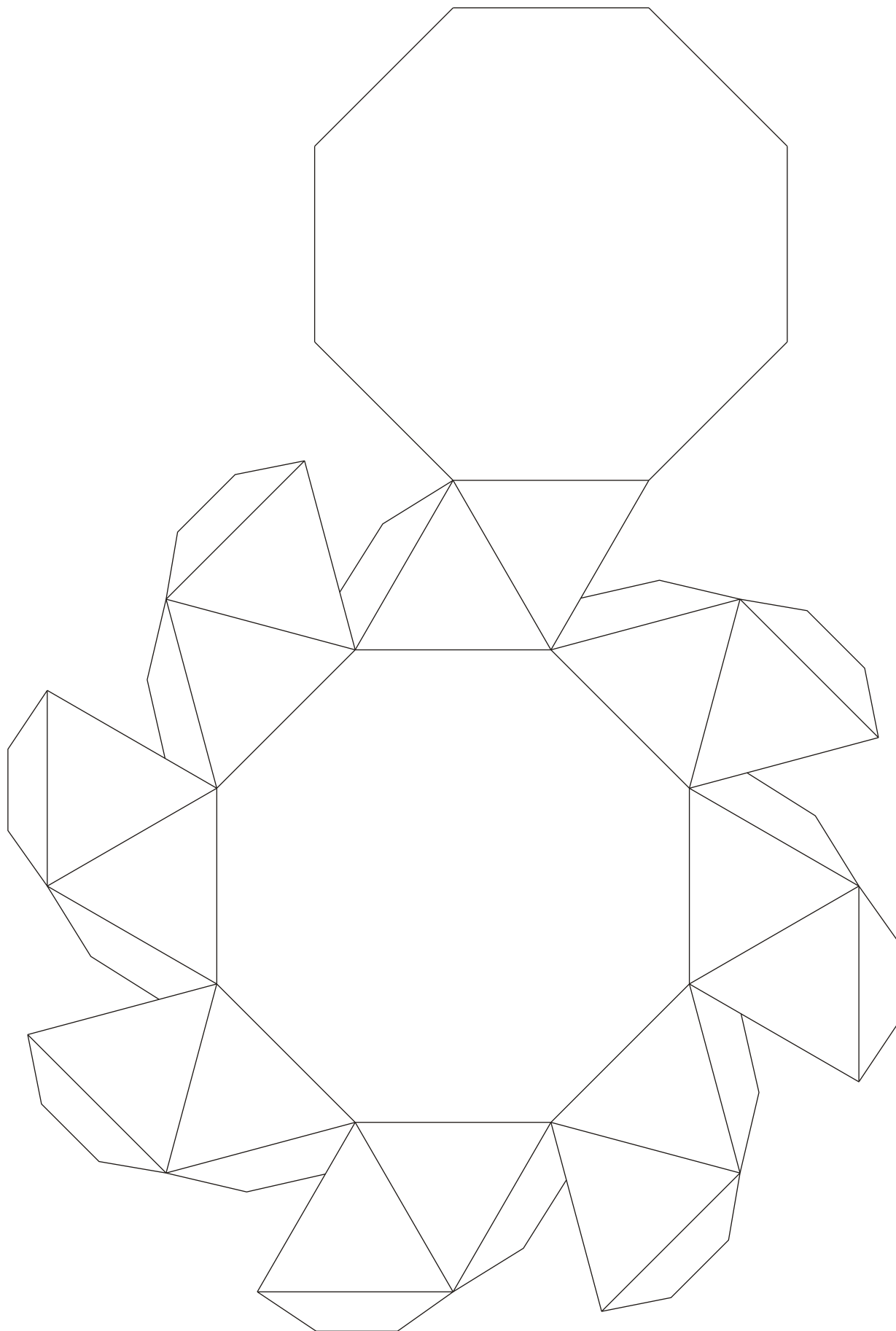

# Pentagrammic Prism

Fold the dotted lines forwards

Fold the other lines backwards

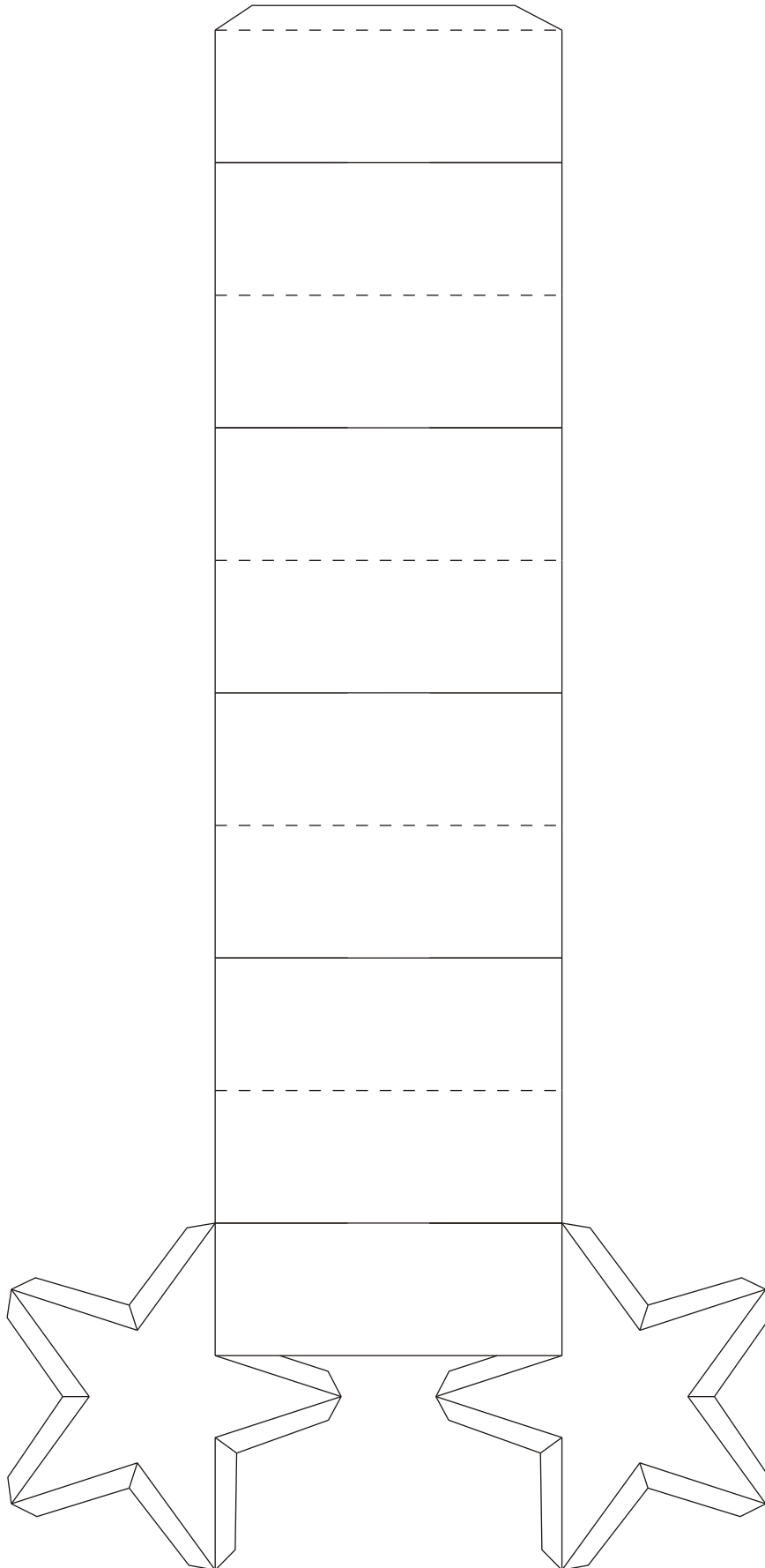

# Pentagrammic Antiprism

Fold the dotted lines forwards

Fold the other lines backwards

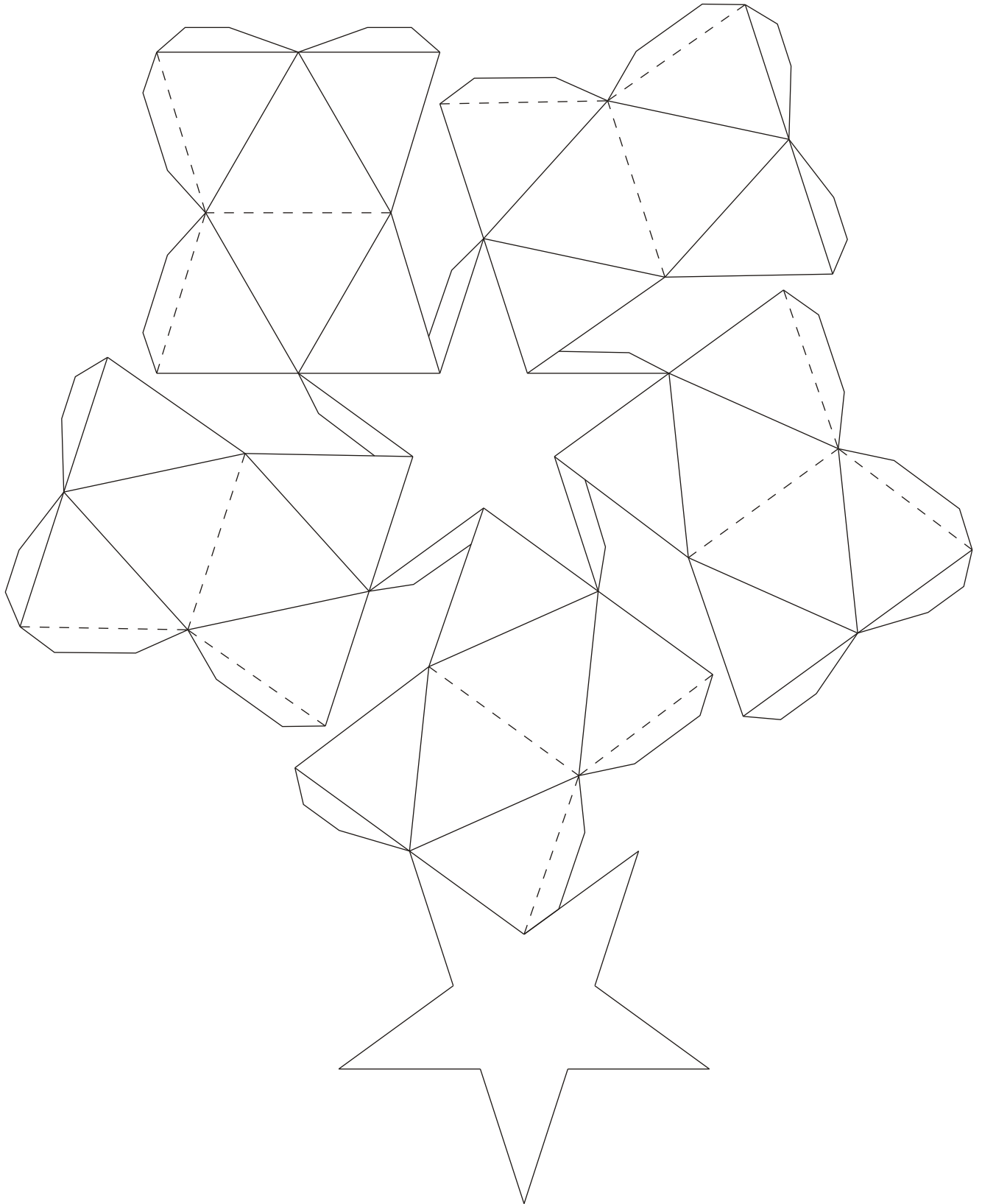

# Hexagrammic Prism

Fold the dotted lines forwards

Fold the other lines backwards

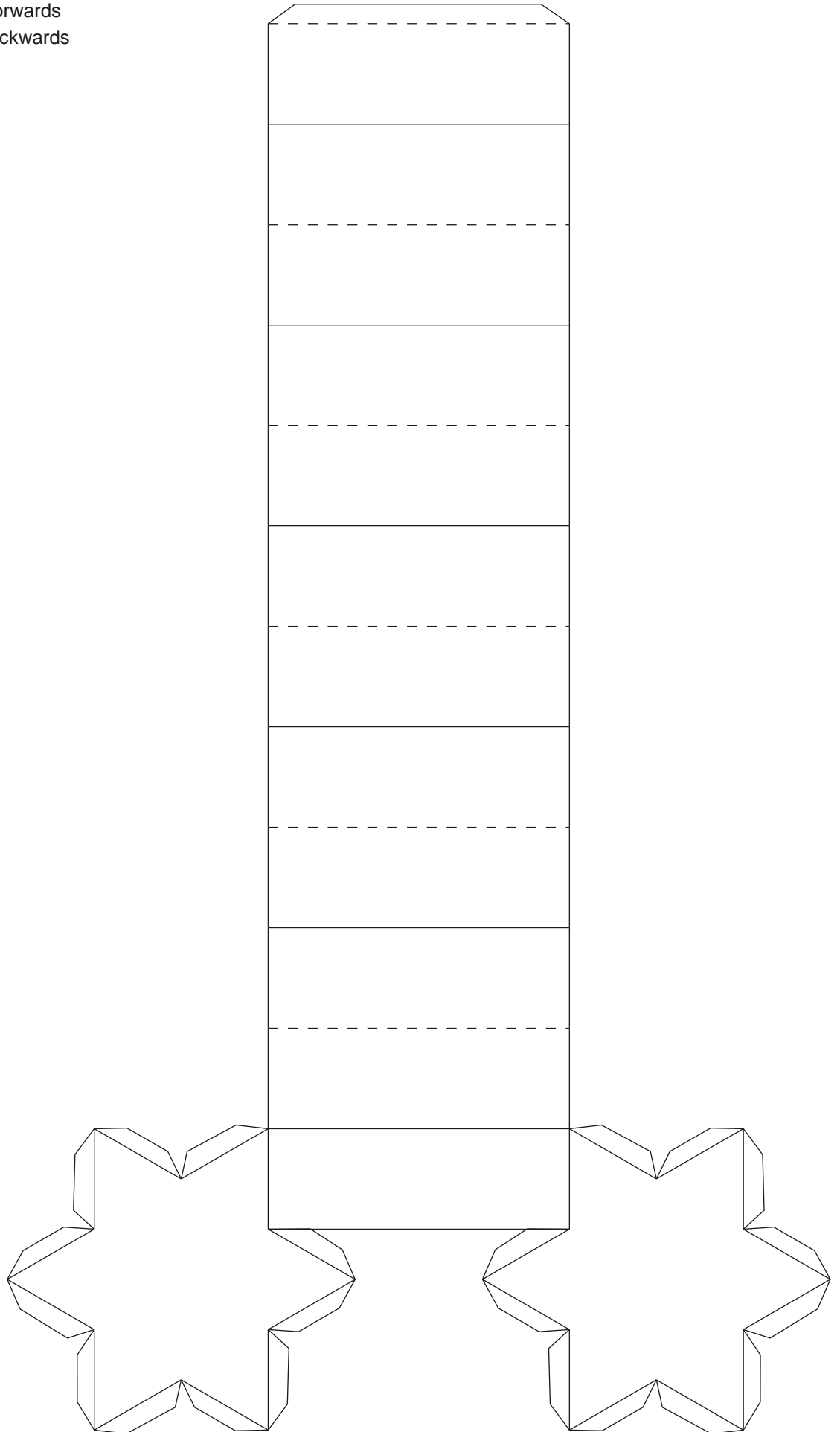

# Hexagrammic Antiprism

Fold the dotted lines forwards

Fold the other lines backwards

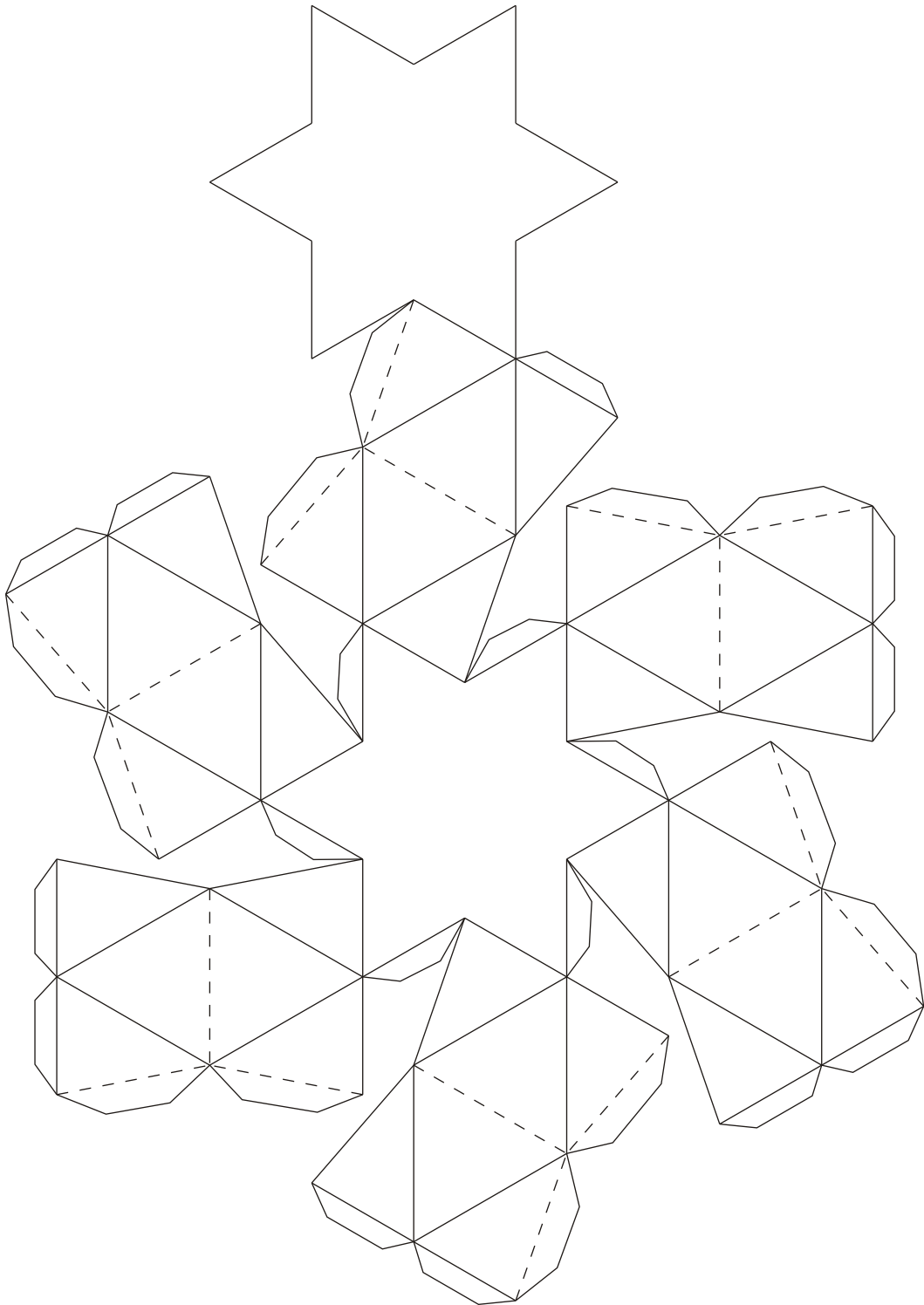

# Twisted rectangular prism (45 degrees)

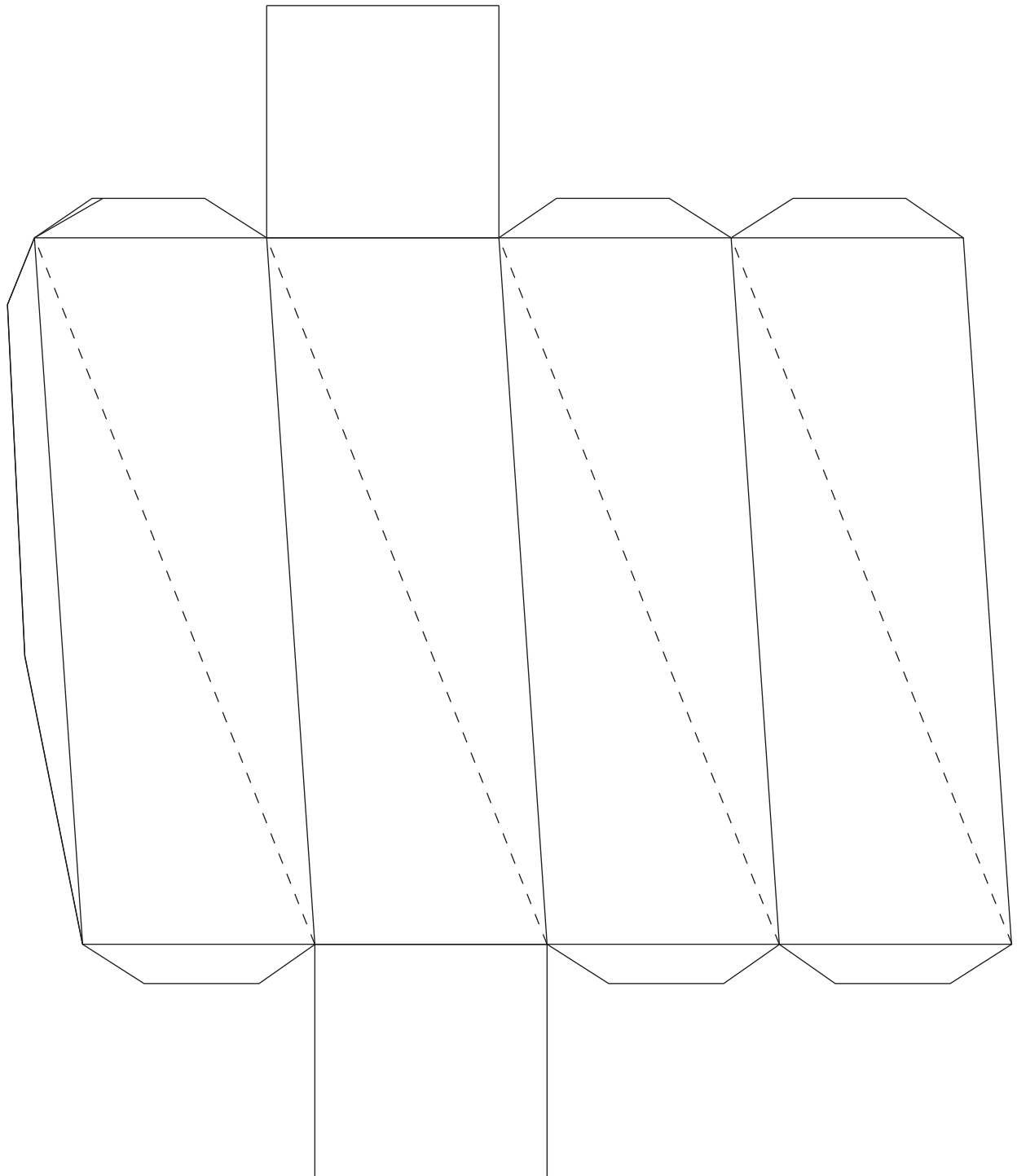



# Twisted rectangular prism (90 degrees)

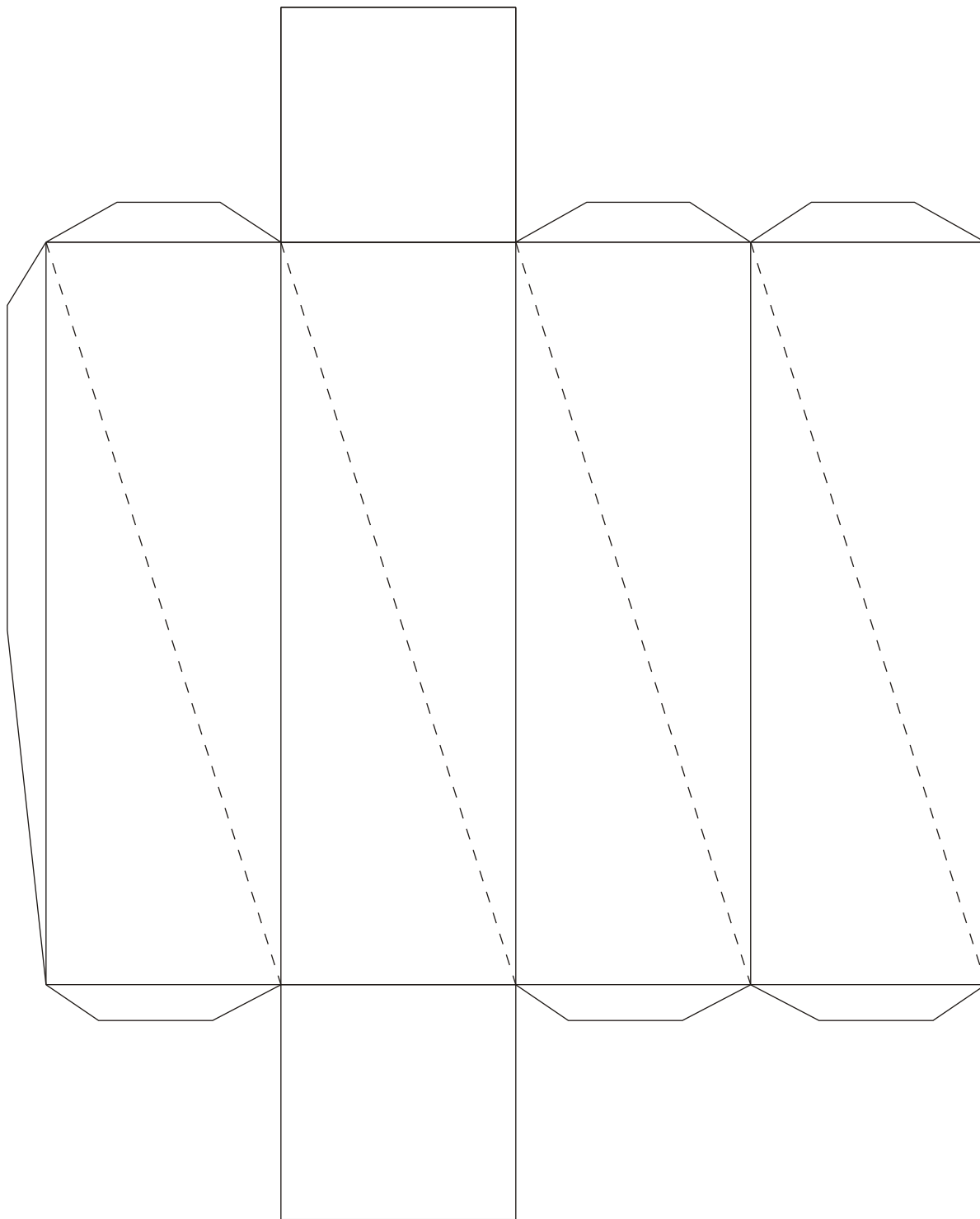

Twisted rectangular prism (+ 45 -45 degrees)

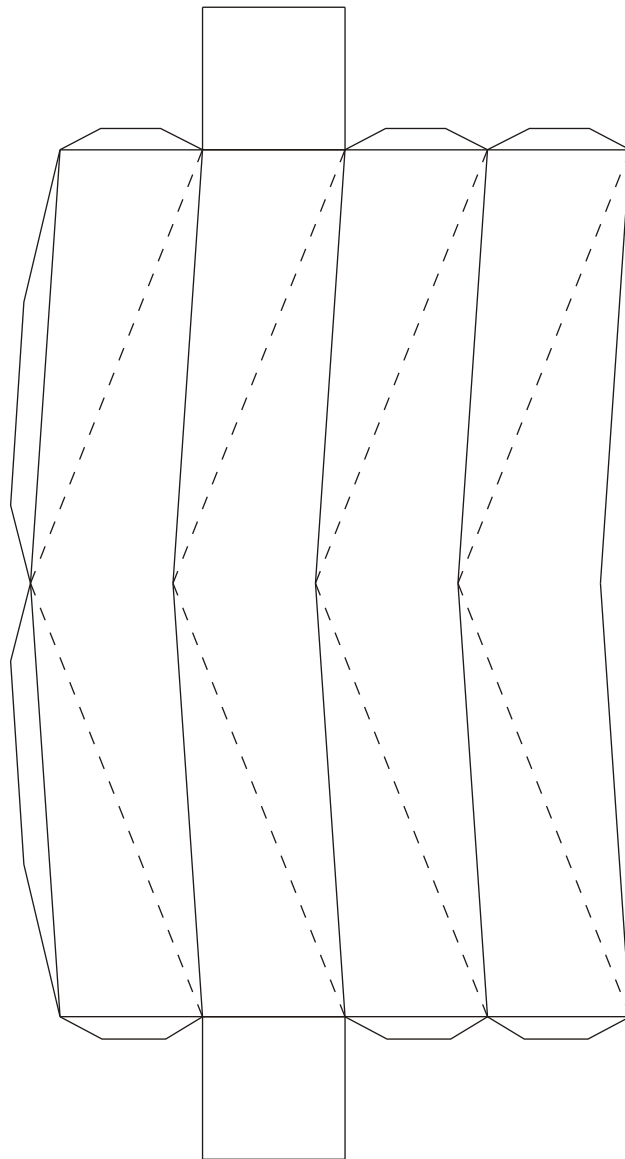

# Kaleidocyclus

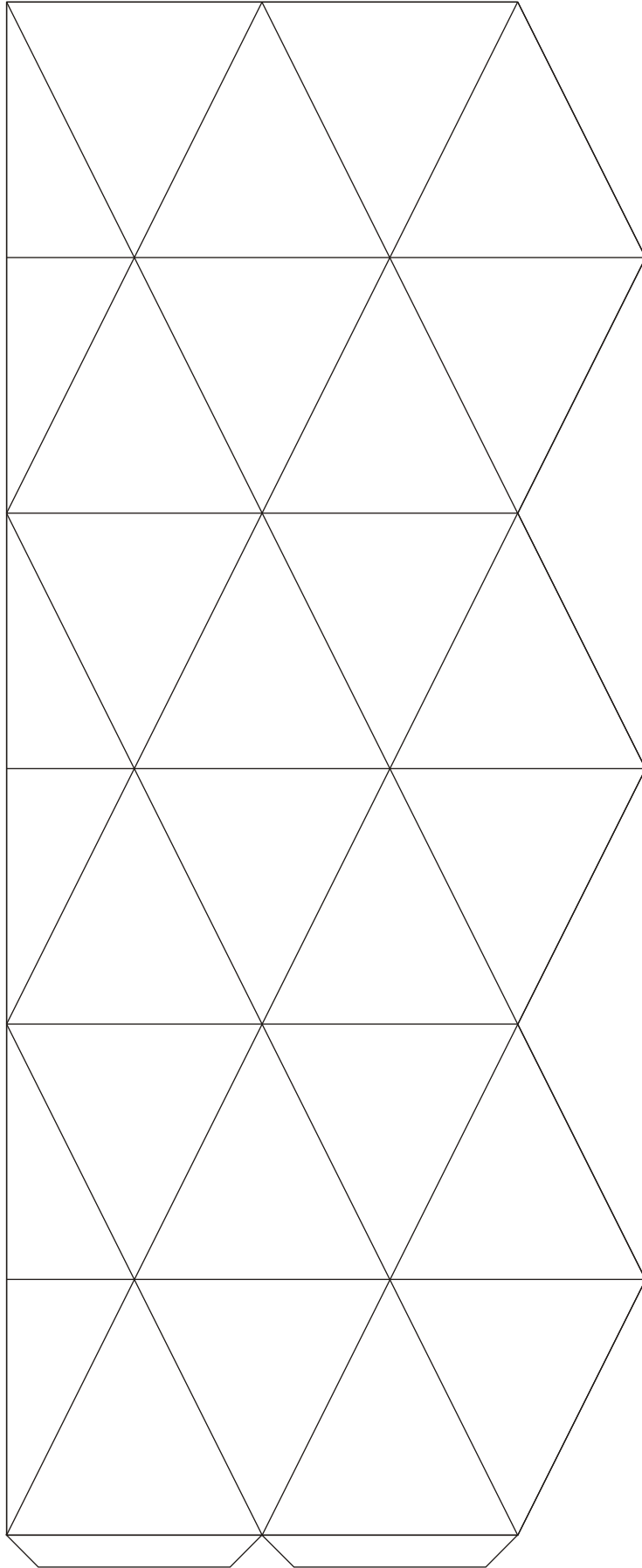

Caleidocycclus 8

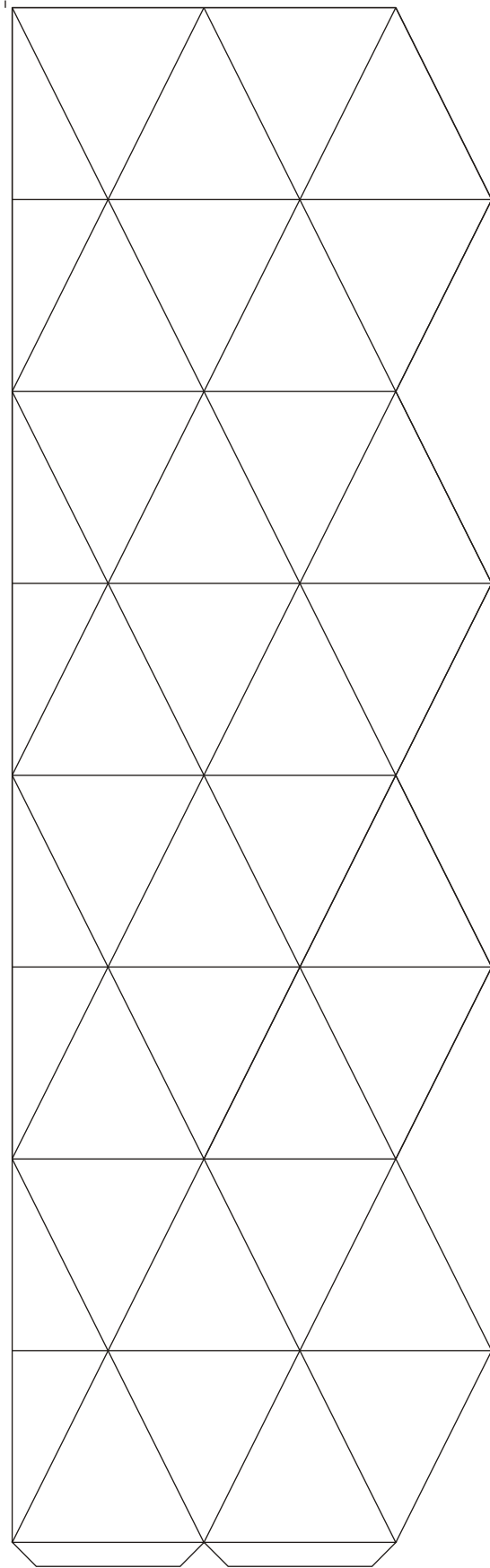

1

Caleidocyclus 10

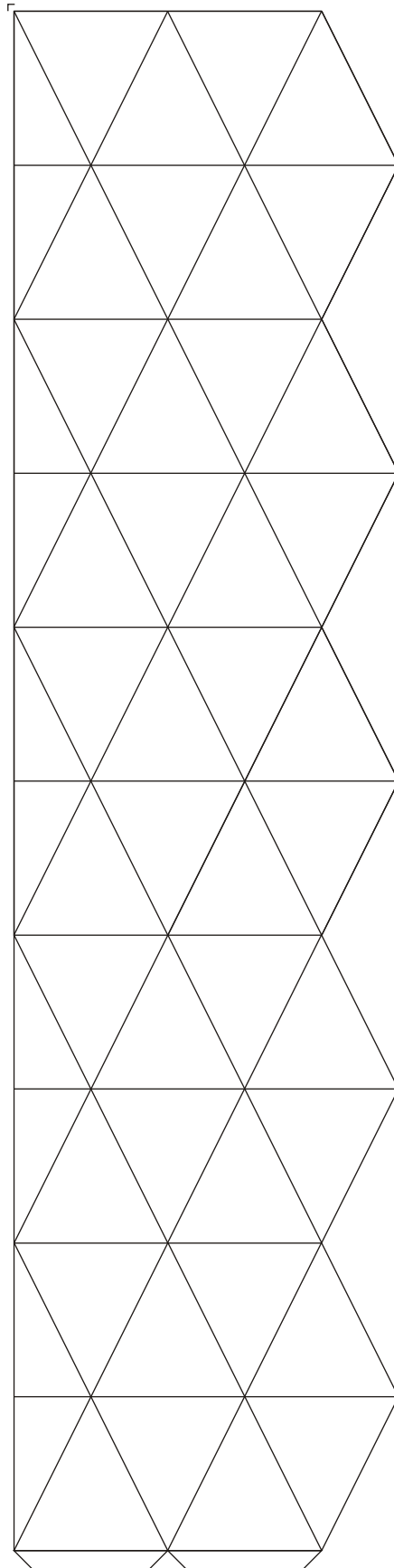

*Cylinder*

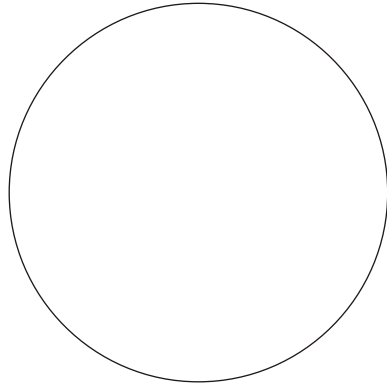
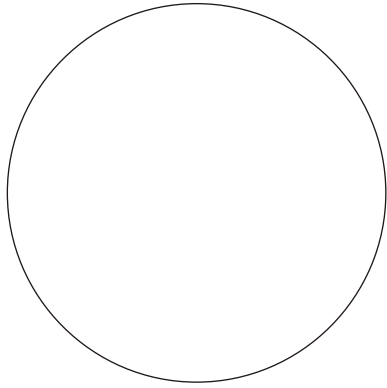

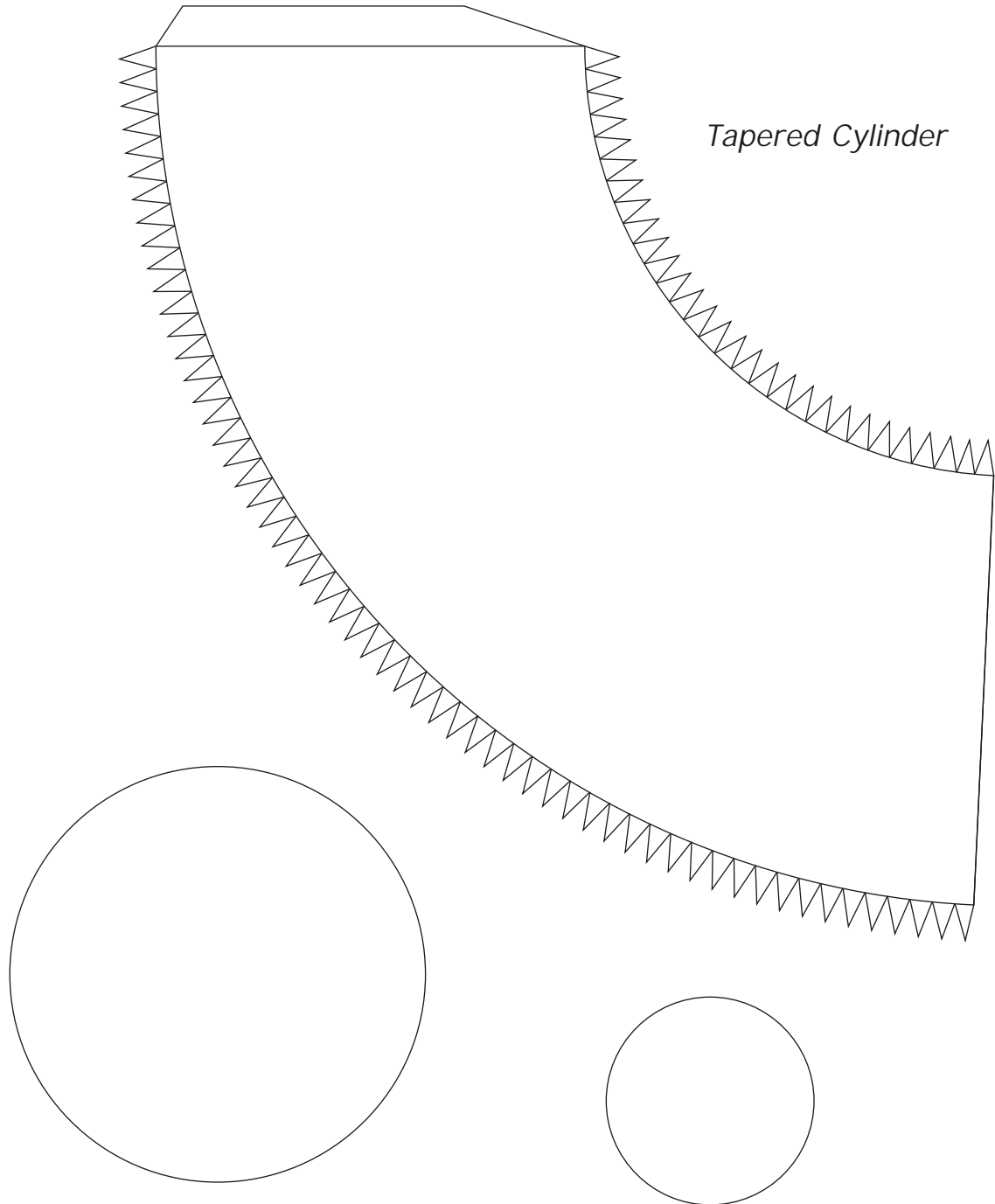

Tapered Cylinder

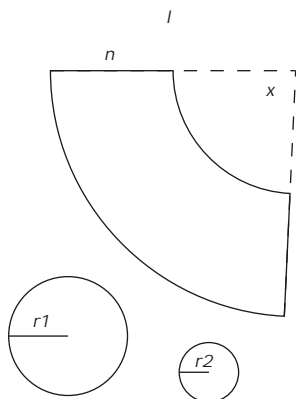

$$l = \sqrt{r^2 + h^2}$$

$$c = 2 \pi r1$$

$$x = 360.2 \cdot \frac{\pi \cdot l}{c}$$

$$d = c \cdot n / l$$

r1 = radius

r2 = radius

c = circumference of circle 1

d = circumference of circle 2

x = angle of the part of the large circle

l = radius of the large circle

h = height of the cone

i = height of the tapered cylinder

$\pi$  = pi = 3.1415

Cone

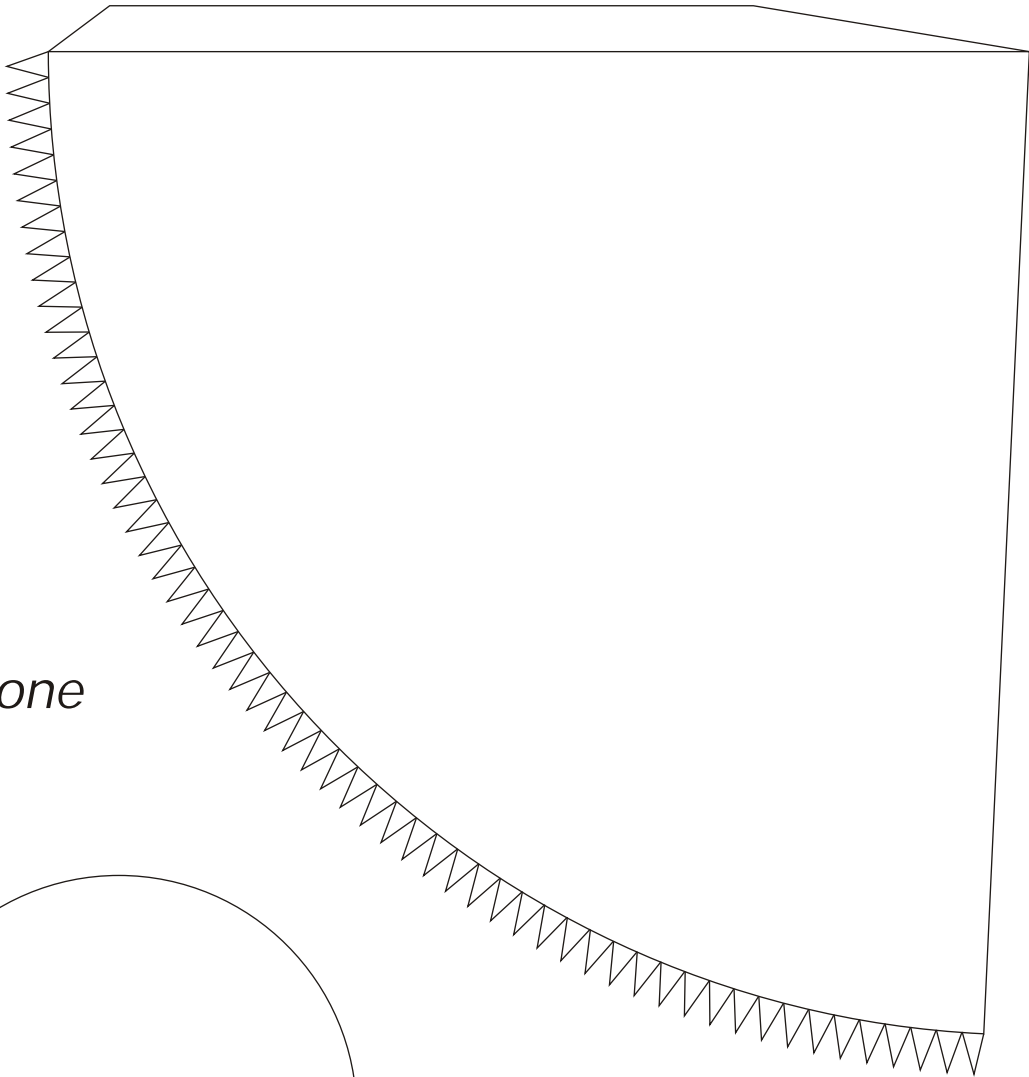
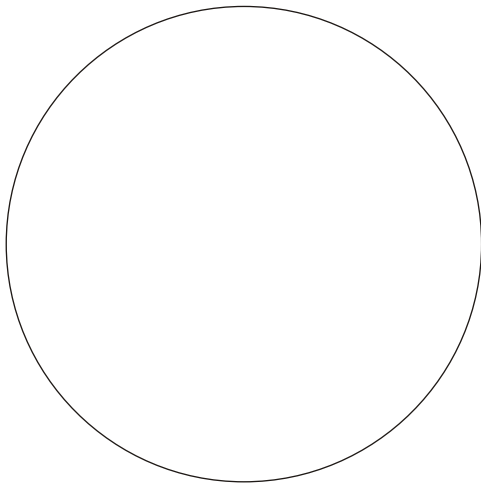

$$l = \sqrt{r^2 + h^2}$$

$$c = 2 \pi r$$

$$x = 360.2 \cdot \pi \cdot l / c$$

*r* = radius  
*c* = circumference of the circle  
*x* = angle of the part of the large circle  
*l* = radius of the large circle  
*h* = height of the cone  
 $\pi$  = pi = 3.1415



# Asymmetric Cone

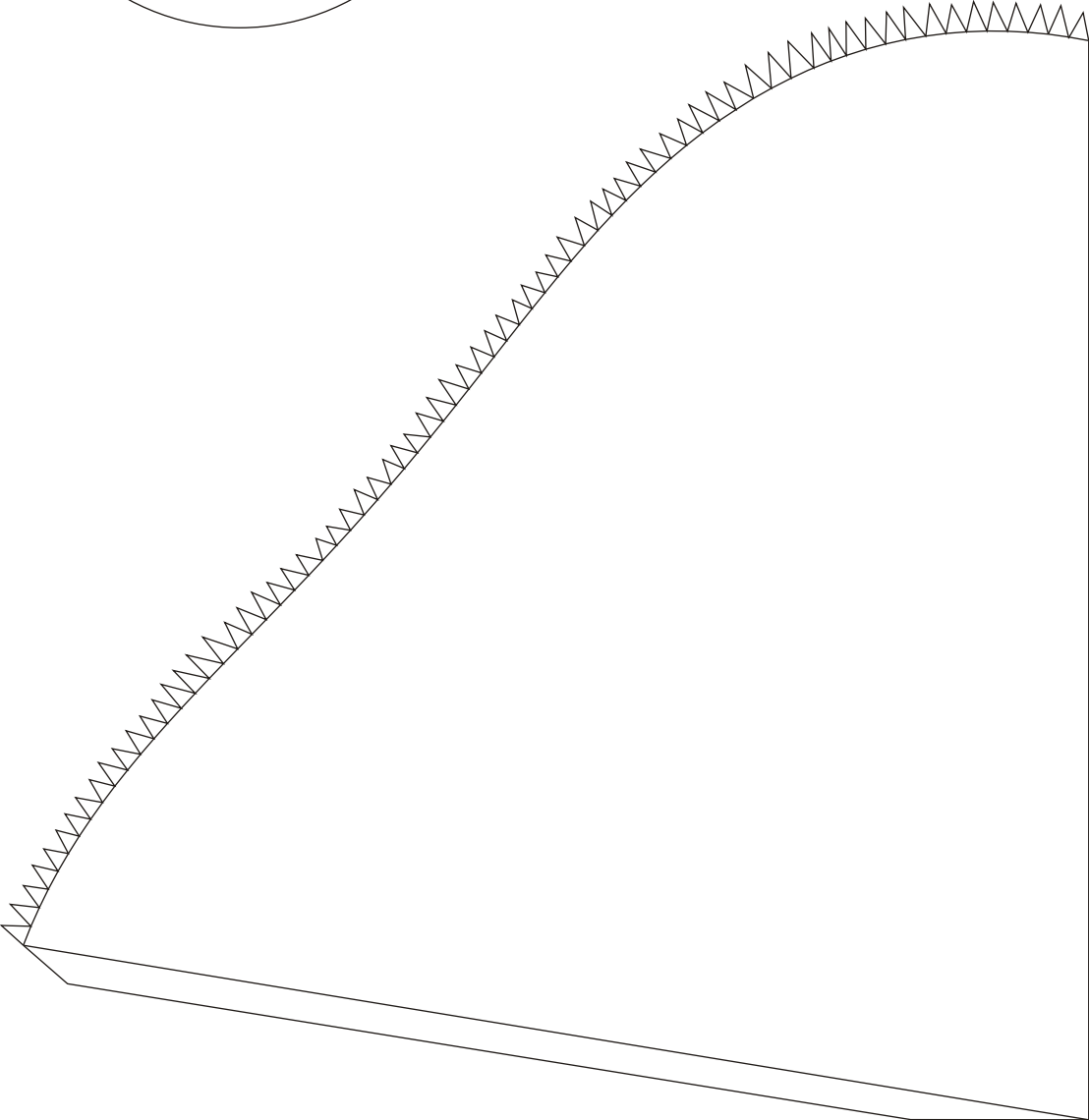
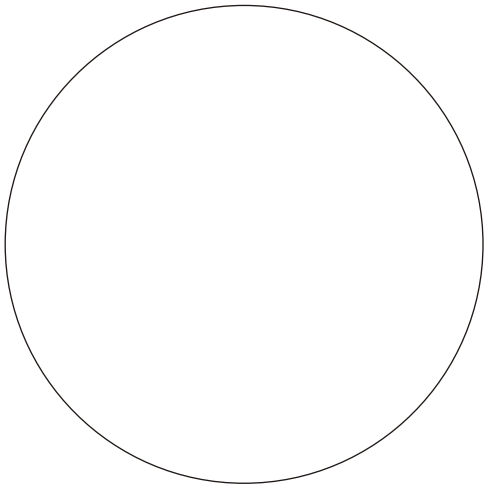

# Square Cone

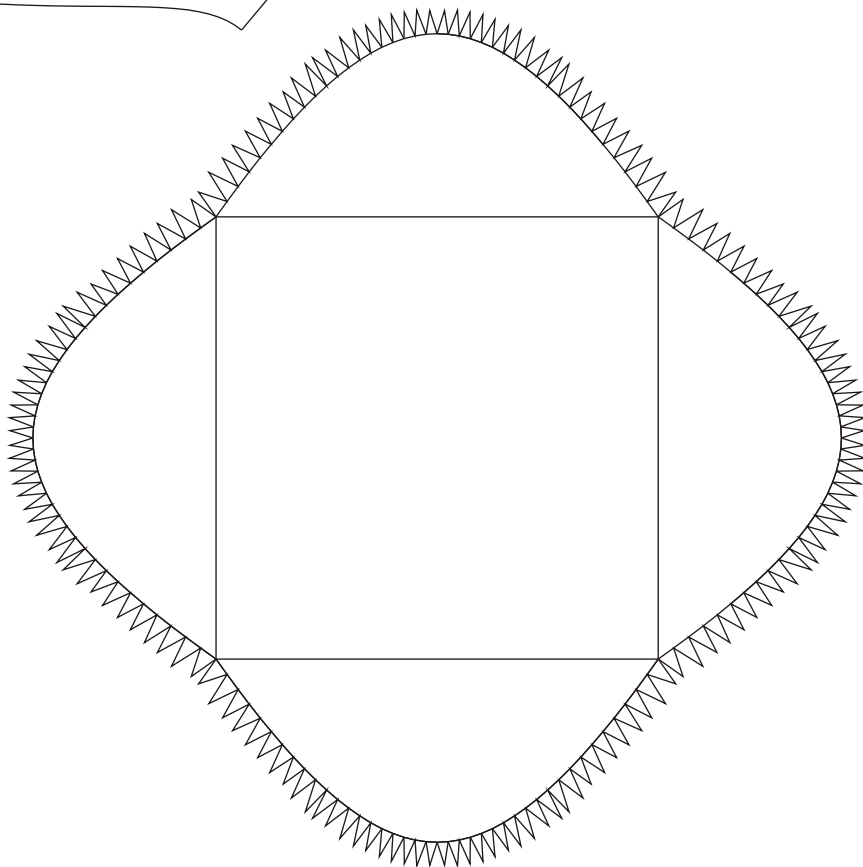
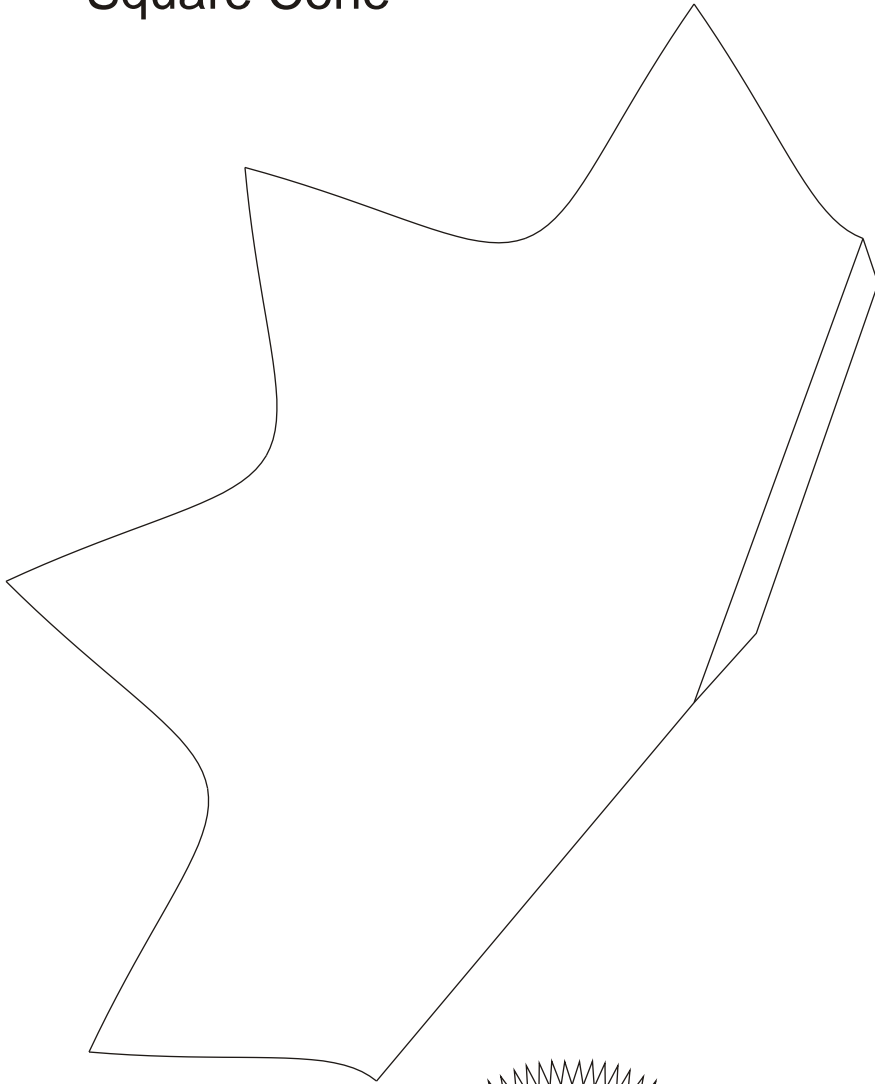

# Square Cone

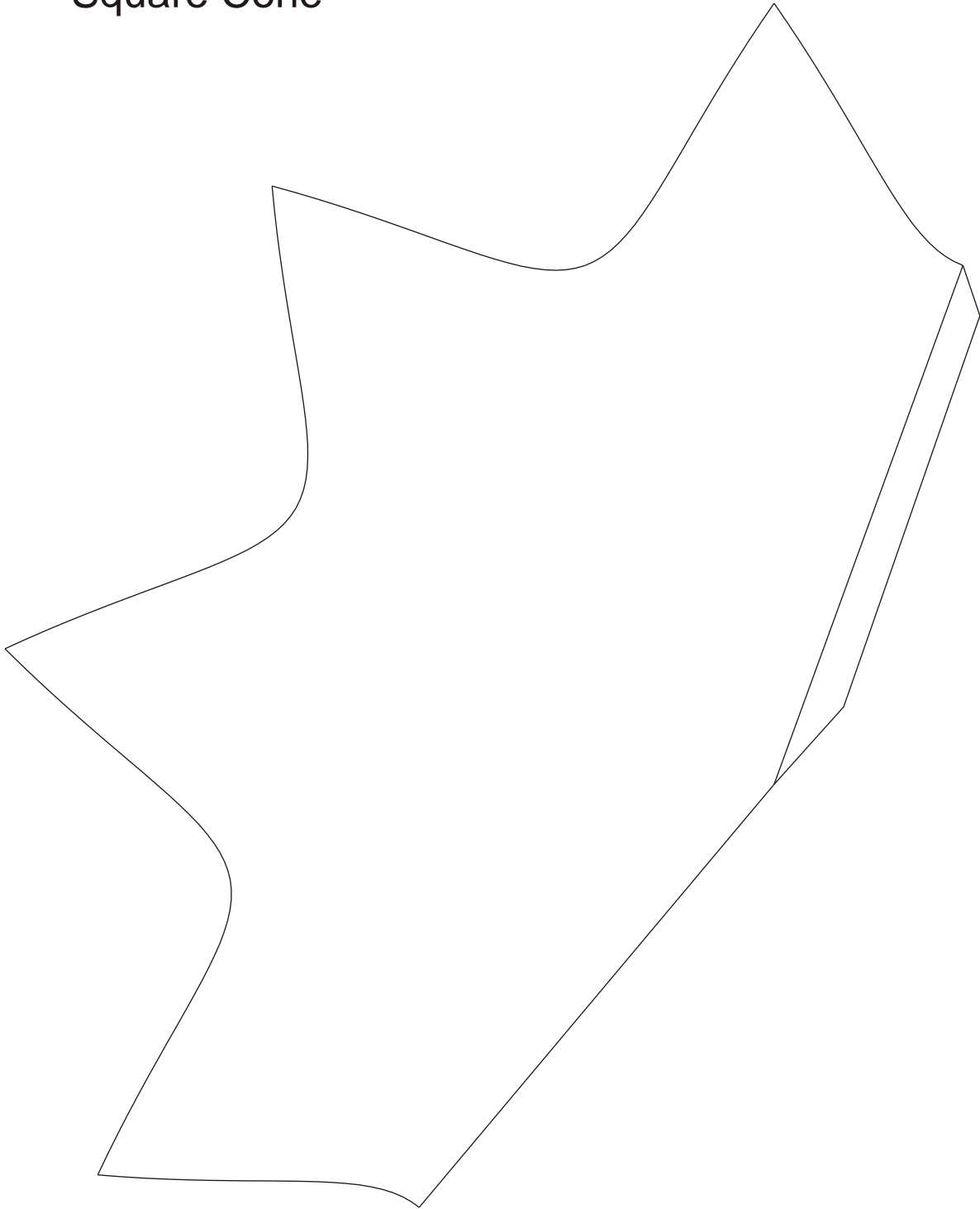

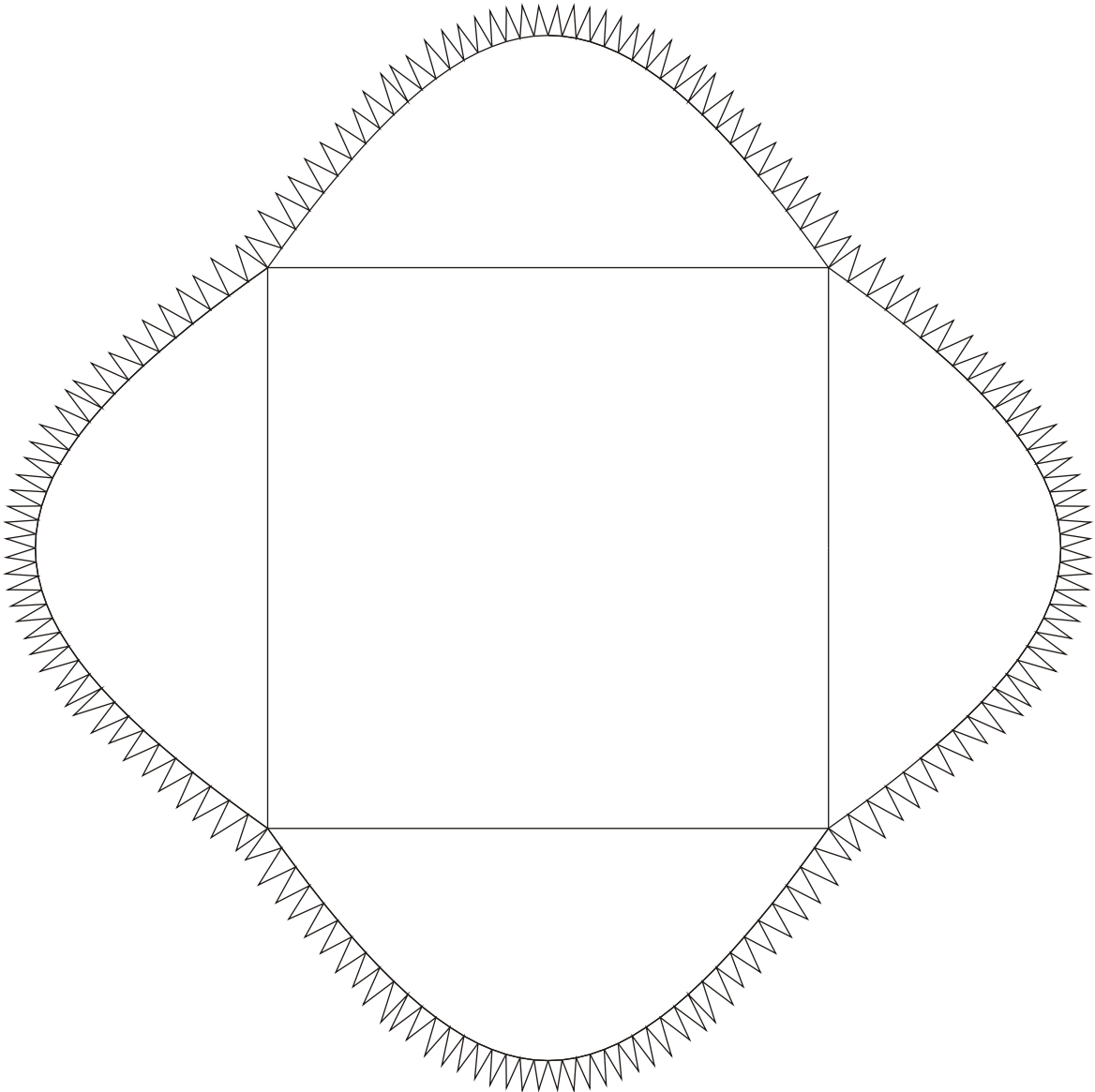

Paper Colour 1/ papier kleur1

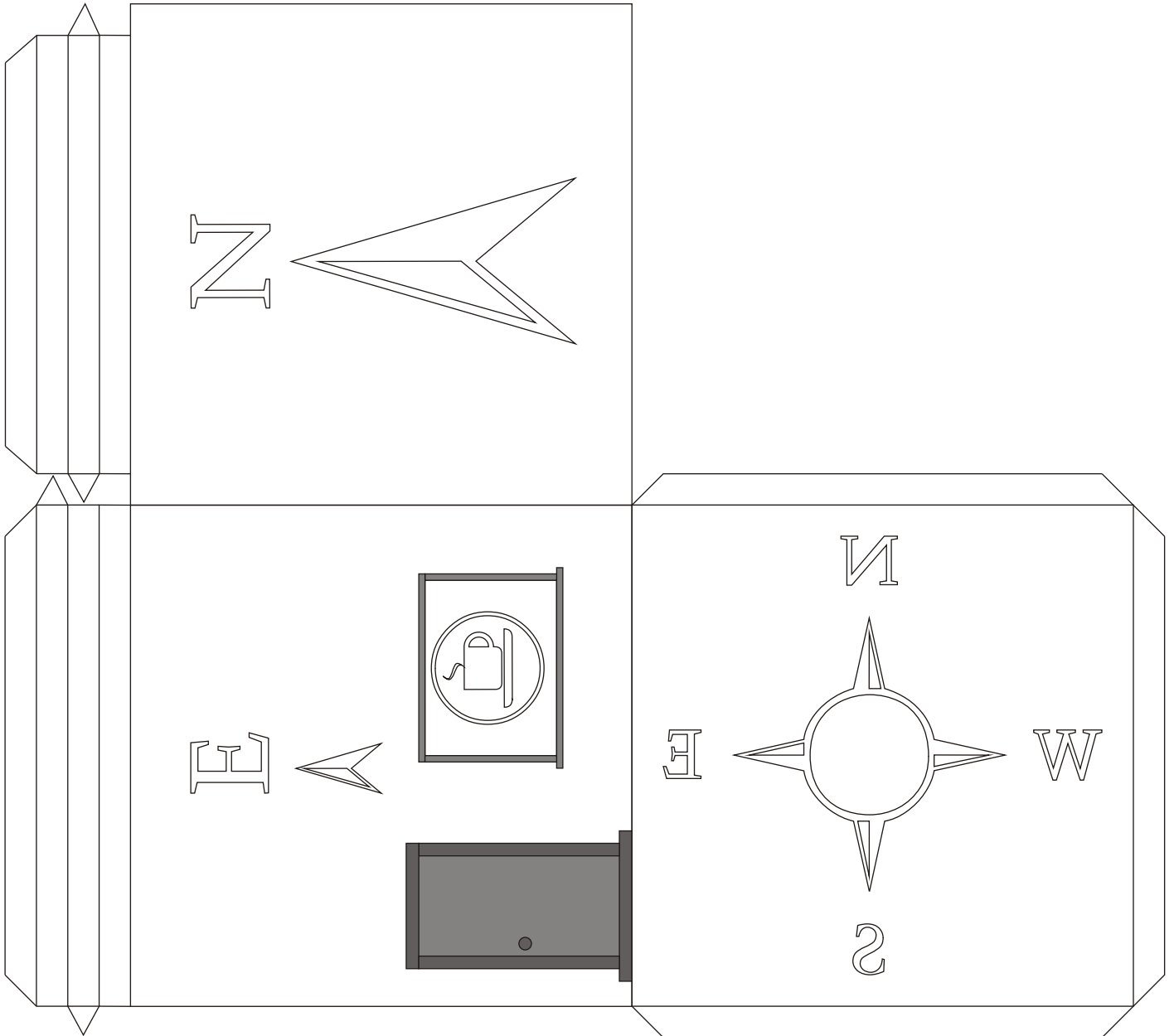

noordelijke, oostelijke muur huis en de bodem

north, east wall of the house and the floor

Paper Colour 1/ papier kleur1

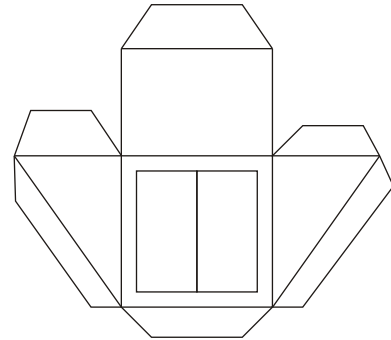
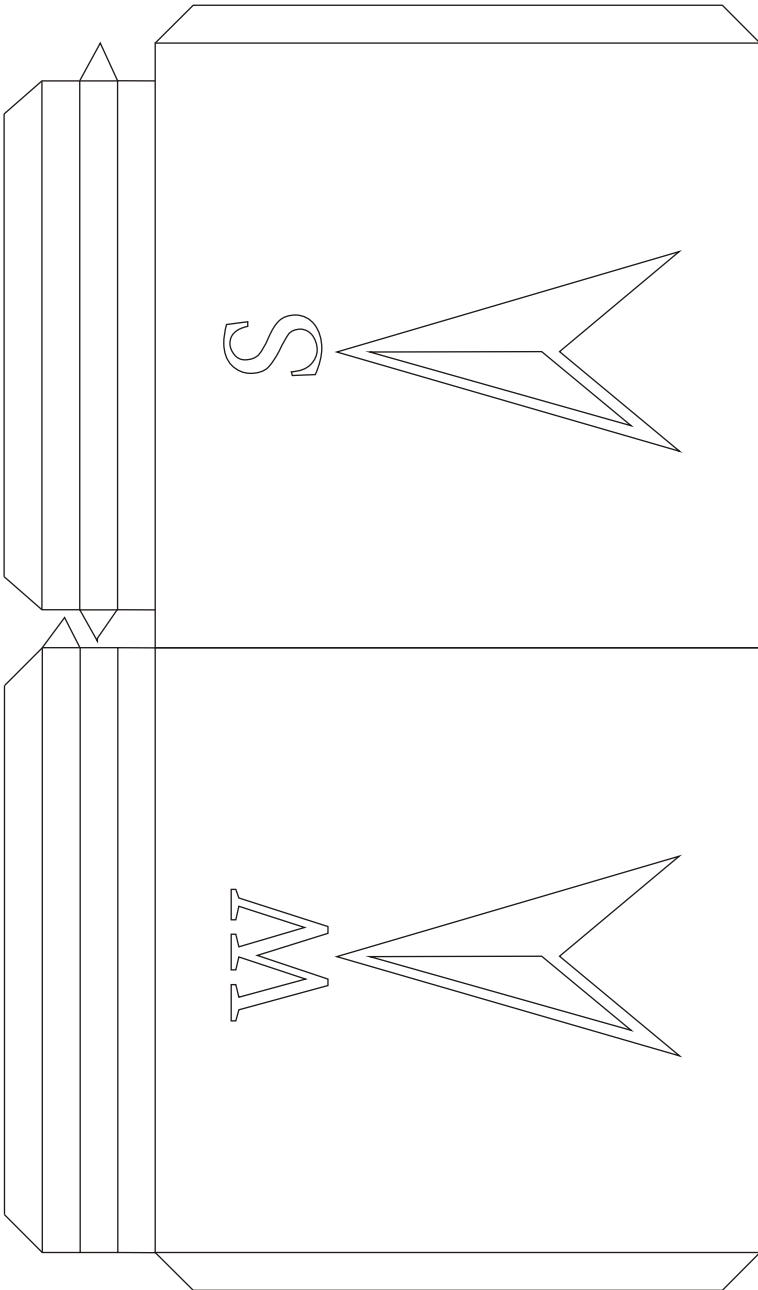

dakkapel  
dormer-window

zuidelijke en westelijke muur huis  
south and west wall house

onderkandak plus twee zijden  
two sides of the roof

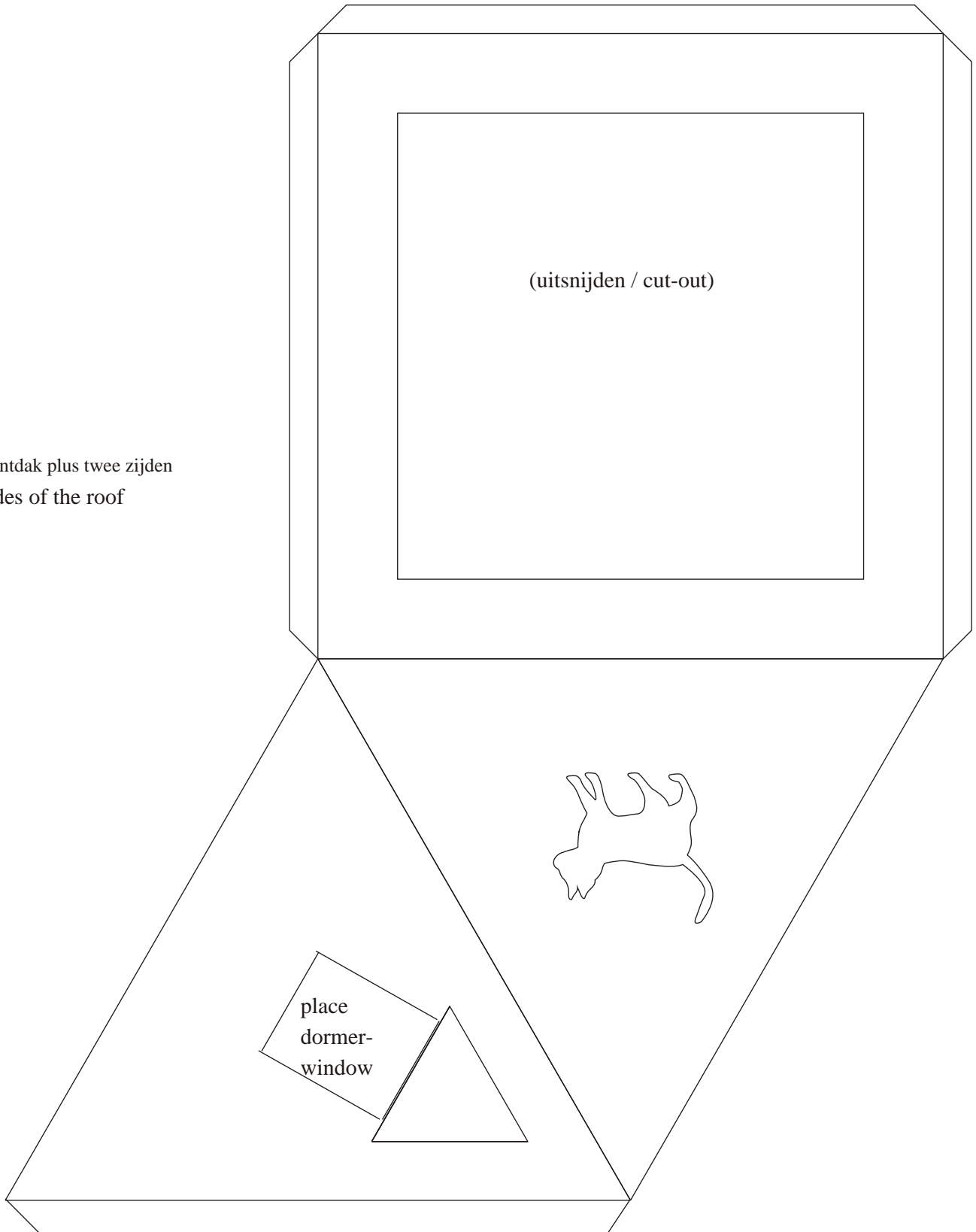

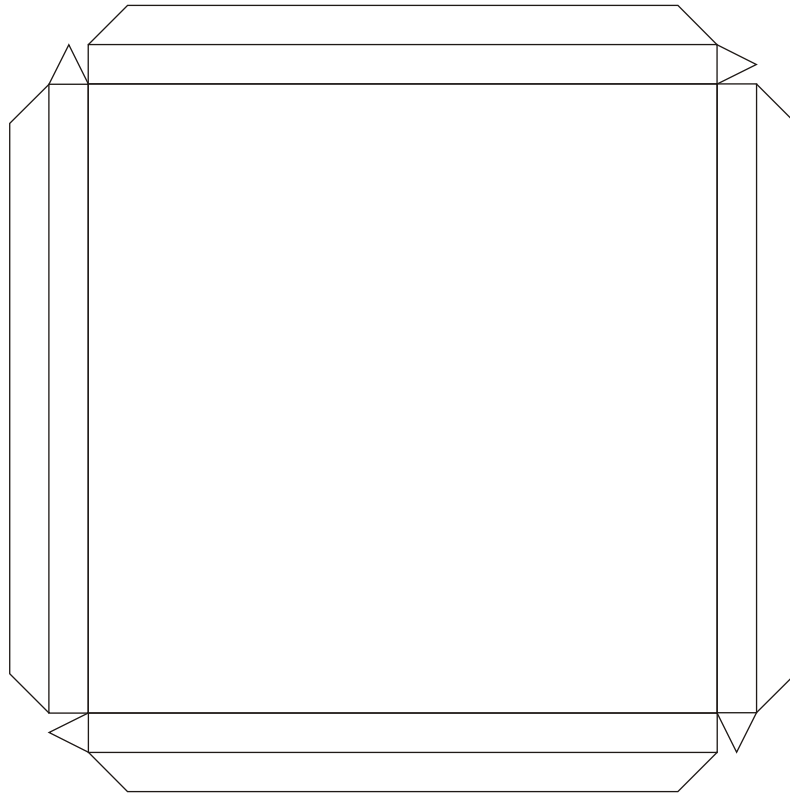

onderkant dak/  
bottom roof  
fits around walls  
don't glue roof on the  
walls

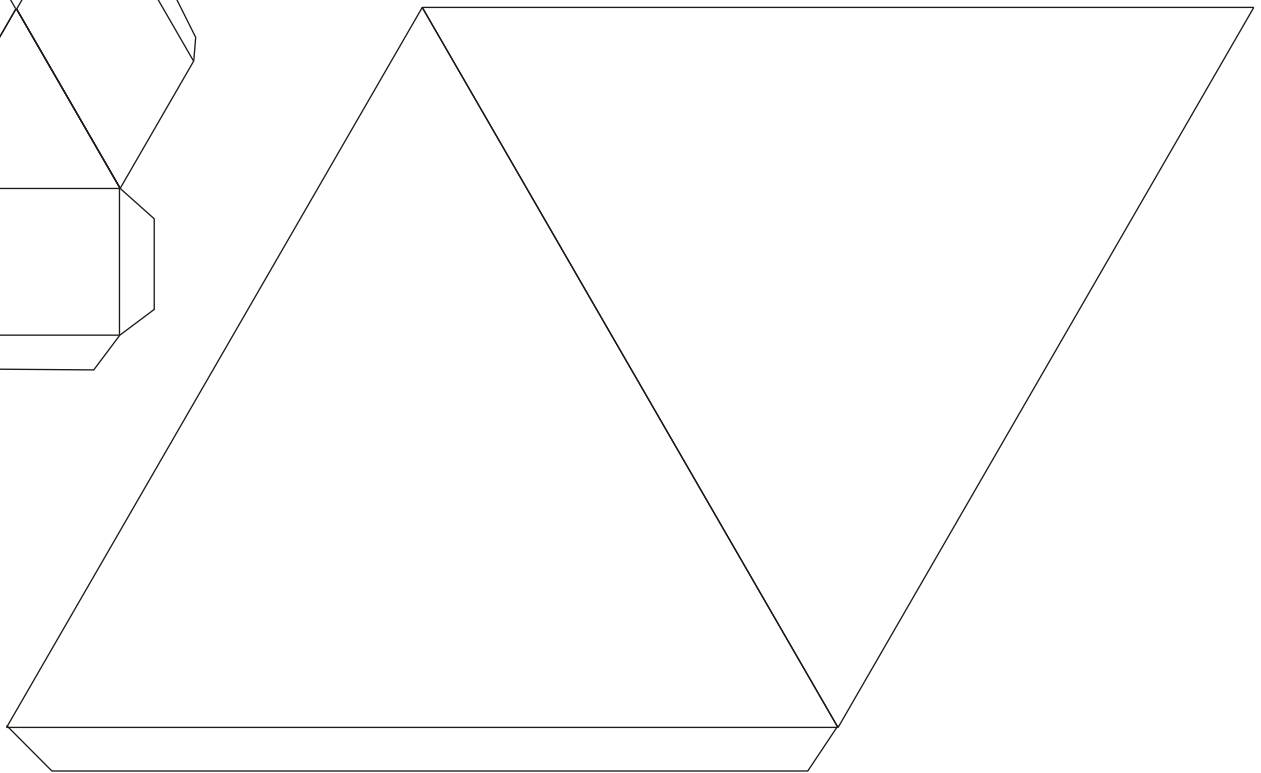
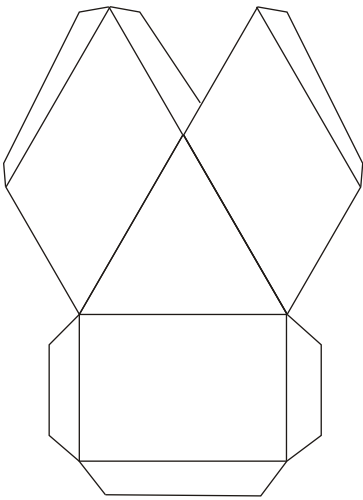

Twee zijden dak  
Two sides of the roof

paper colour 2 / papier kleur 2



Paper Colour 1/ papier kleur1

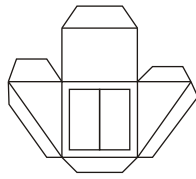
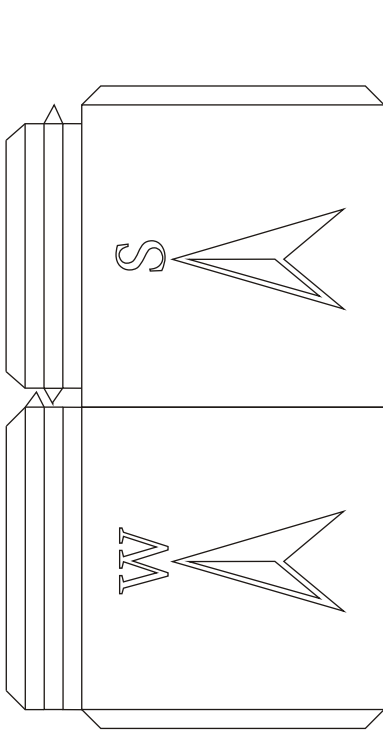

dakkapel  
dormer-window

zuidelijke en westelijke muur huis  
south and west wall house

Paper Colour 1/ papier kleur1

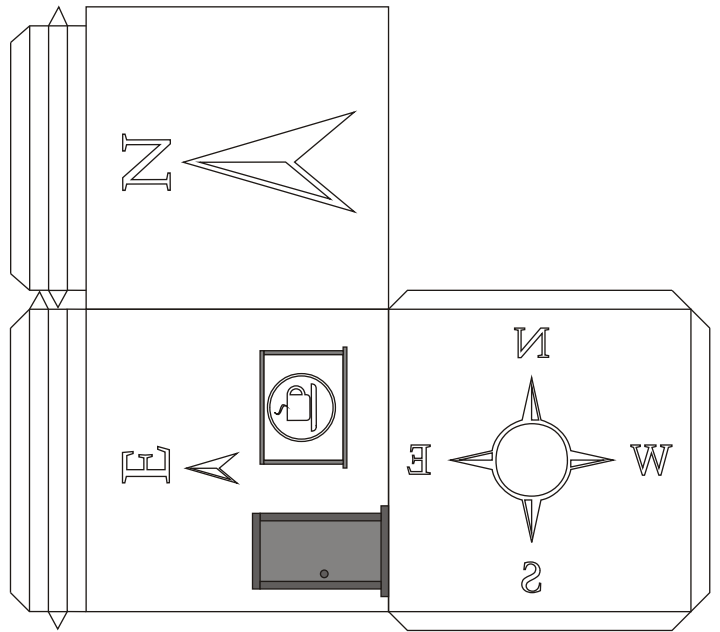

noordelijke, oostelijke muur huis en de bodem  
north, east wall of the house and the floor

Paper Colour 1/ papier kleur1

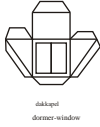
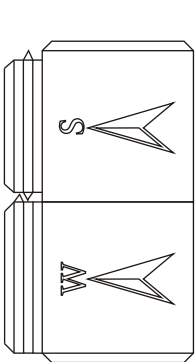

zuidelijke en westelijke muur huis  
south and west wall house

Paper Colour 1/ papier kleur1

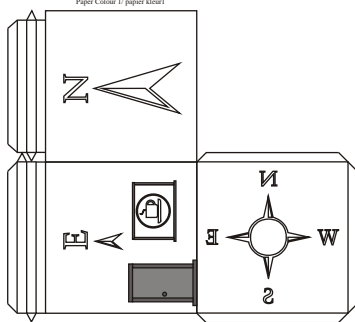

noordelijke, oostelijke muur huis en de bodem  
north, east wall of the house and the floor

Paper Colour 1/ papier kleur1

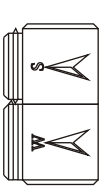

zuidelijke en westelijke muur huis  
south and west wall house

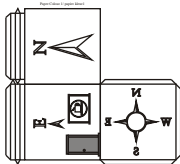

noordelijke, oostelijke muur huis en de bodem  
north, east wall of the house and the floor

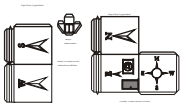

zuidelijke en westelijke muur huis  
south and west wall house

paper colour 2 / papier kleur 2

onderkandak plus twee zijden  
two sides of the roof

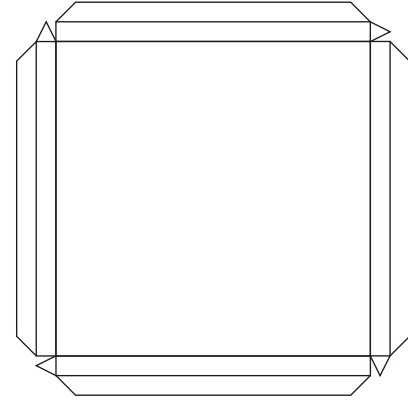
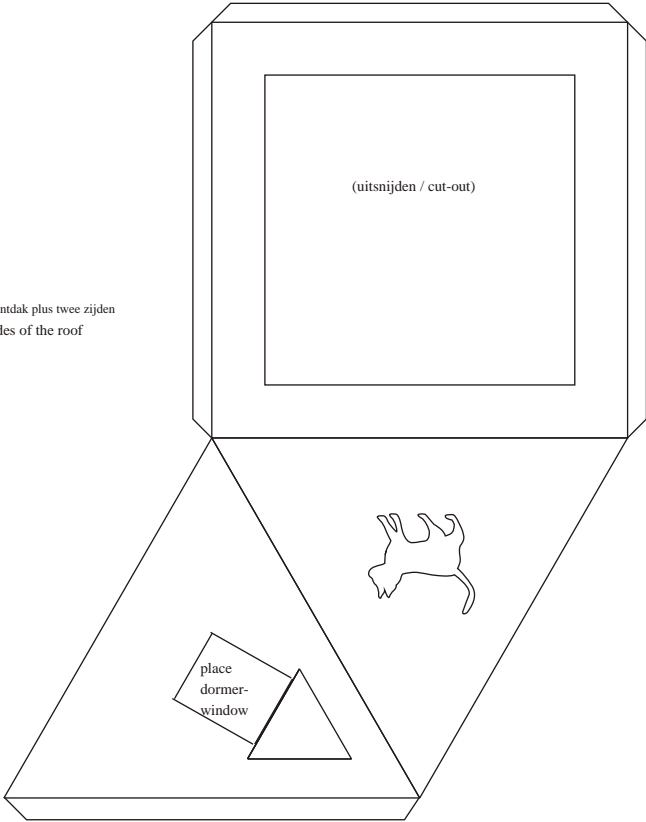

onderkant dak/  
bottom roof  
fits around walls  
don't glue roof on the  
walls

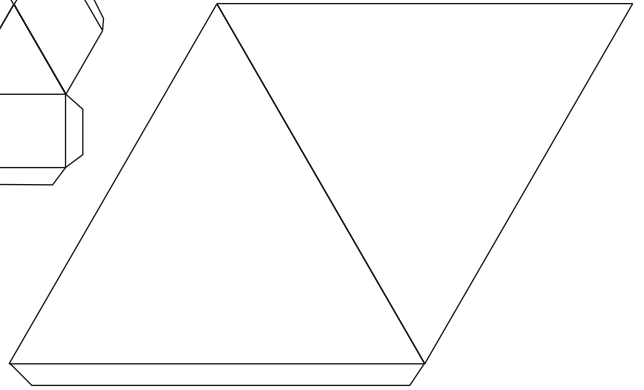
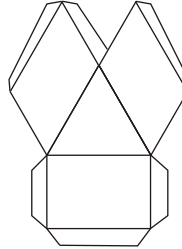

Twee zijden dak  
Two sides of the roof

paper colour 2 / papier kleur 2

paper colour 2 / papier kleur 2

onderkandak plus twee zijden  
two sides of the roof

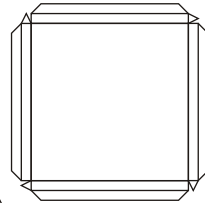
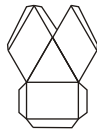
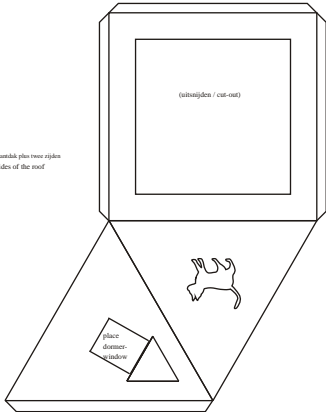

onderkant dak/  
bottom roof  
fits around walls  
don't glue roof on the  
walls

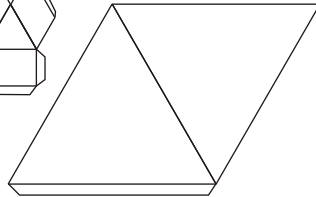

Twee zijden dak  
Two sides of the roof

paper colour 2 / papier kleur 2

paper colour 2 / papier kleur 2

paper colour 2 / papier kleur 2

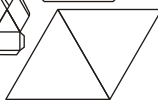
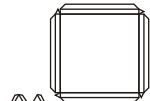
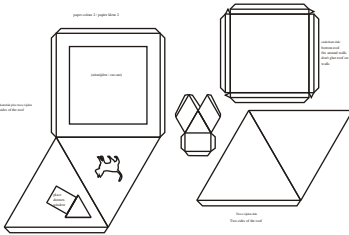

Twee zijden dak  
Two sides of the roof

paper colour 2 / papier kleur 2

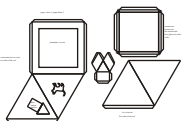

paper colour 2 / papier kleur 2

Globe

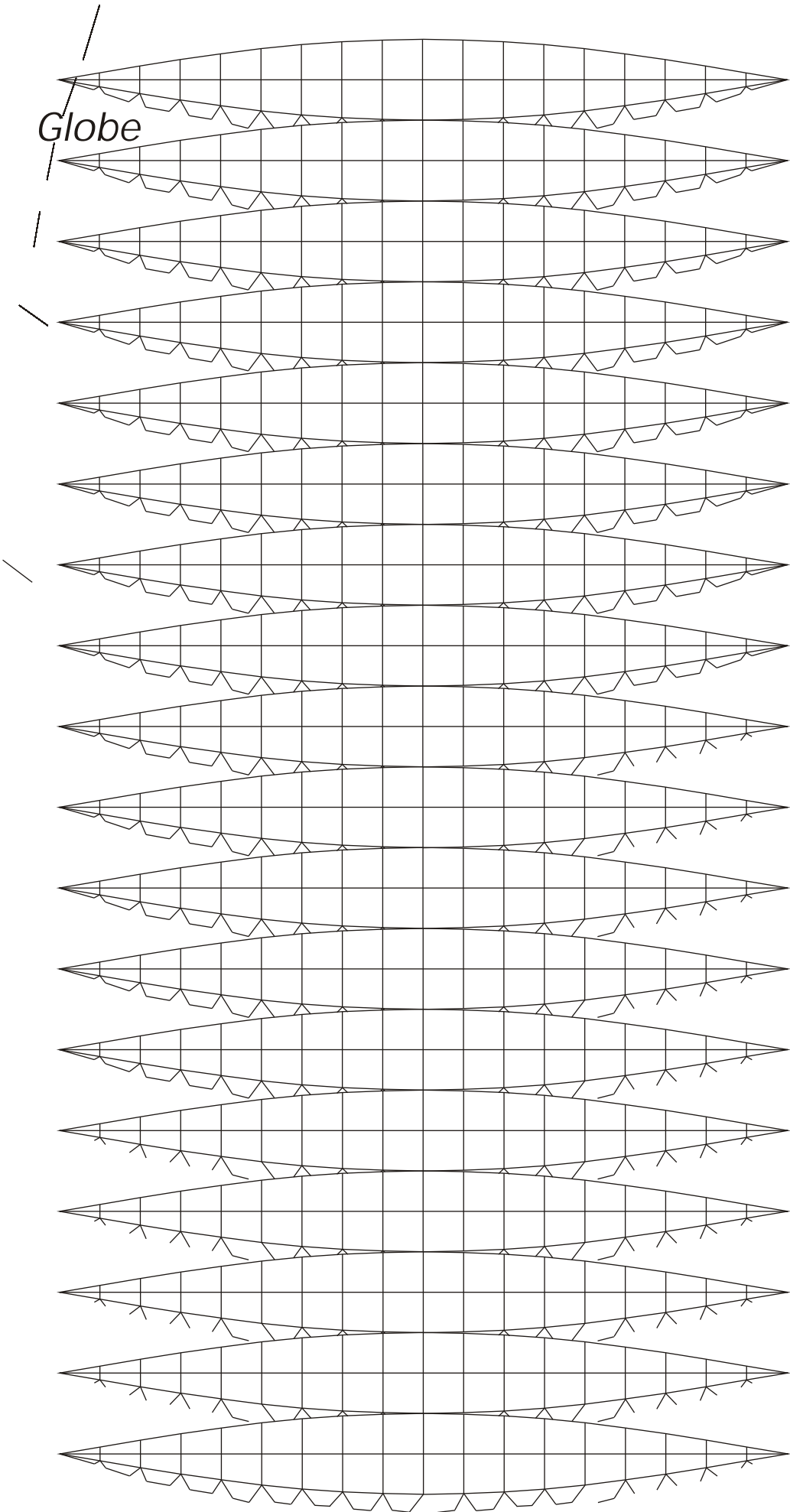

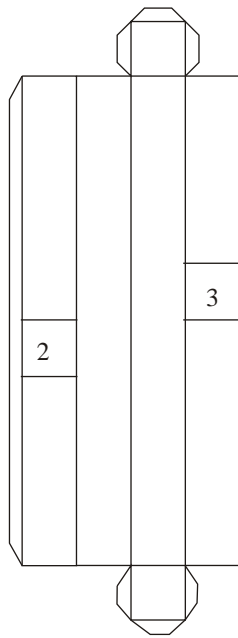
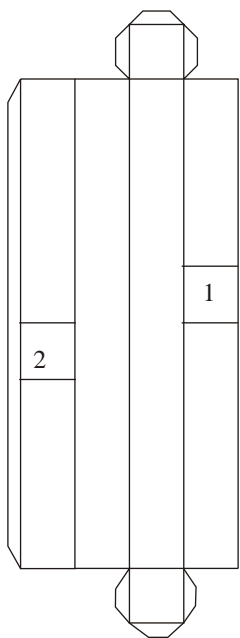
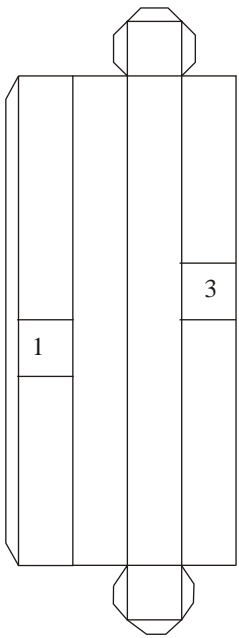
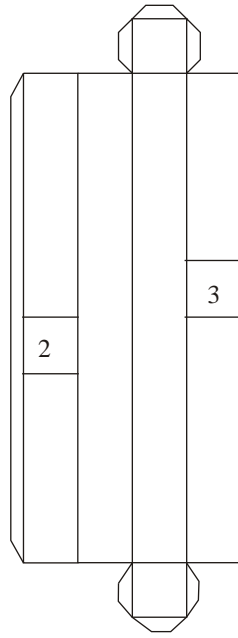
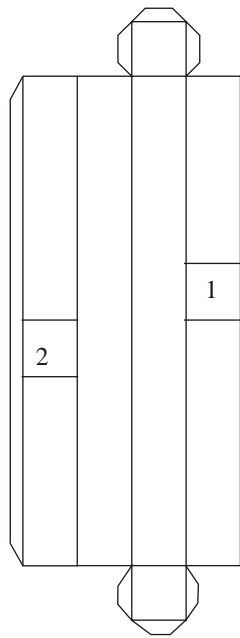
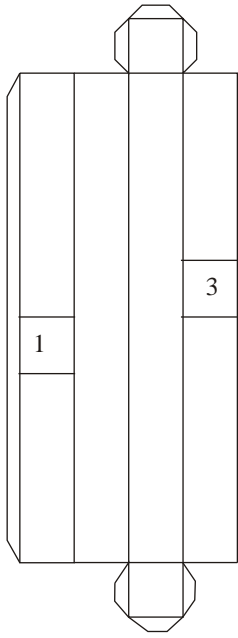
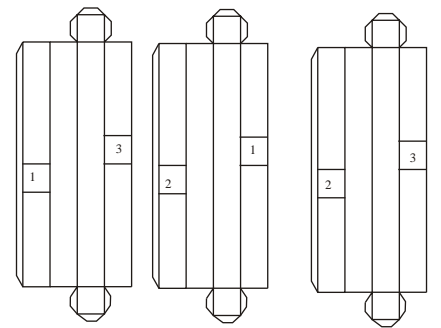
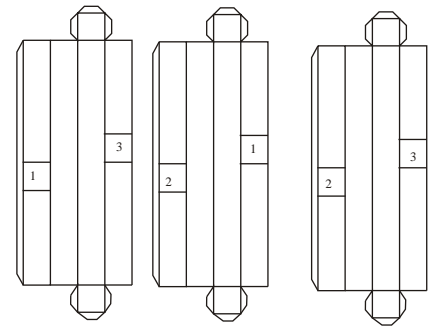
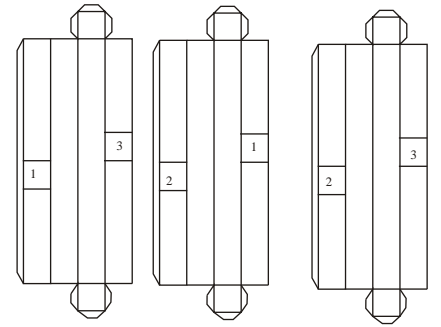
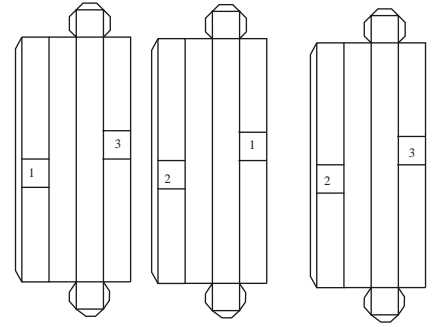
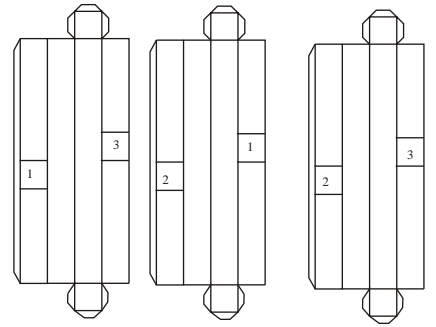
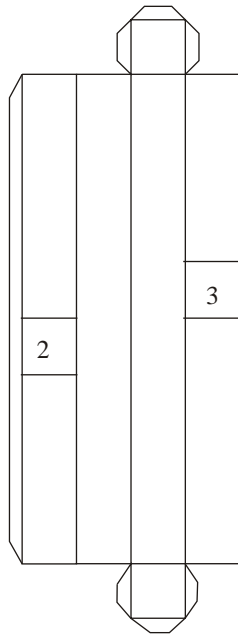
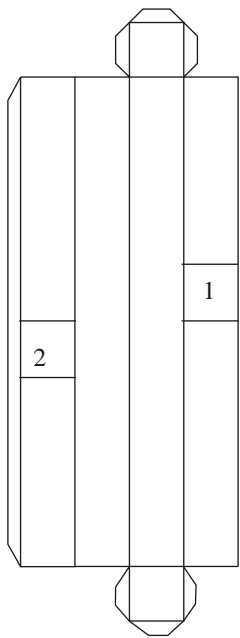
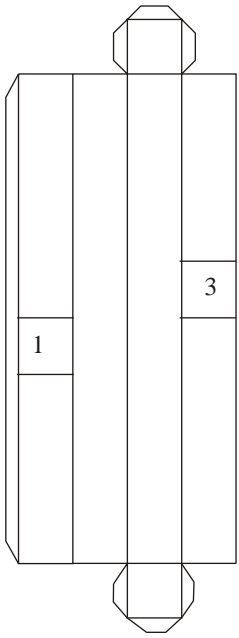

# Large Chevaux-de-frise

The other two parts are on the next two pages

